

★ This part is not serviced.

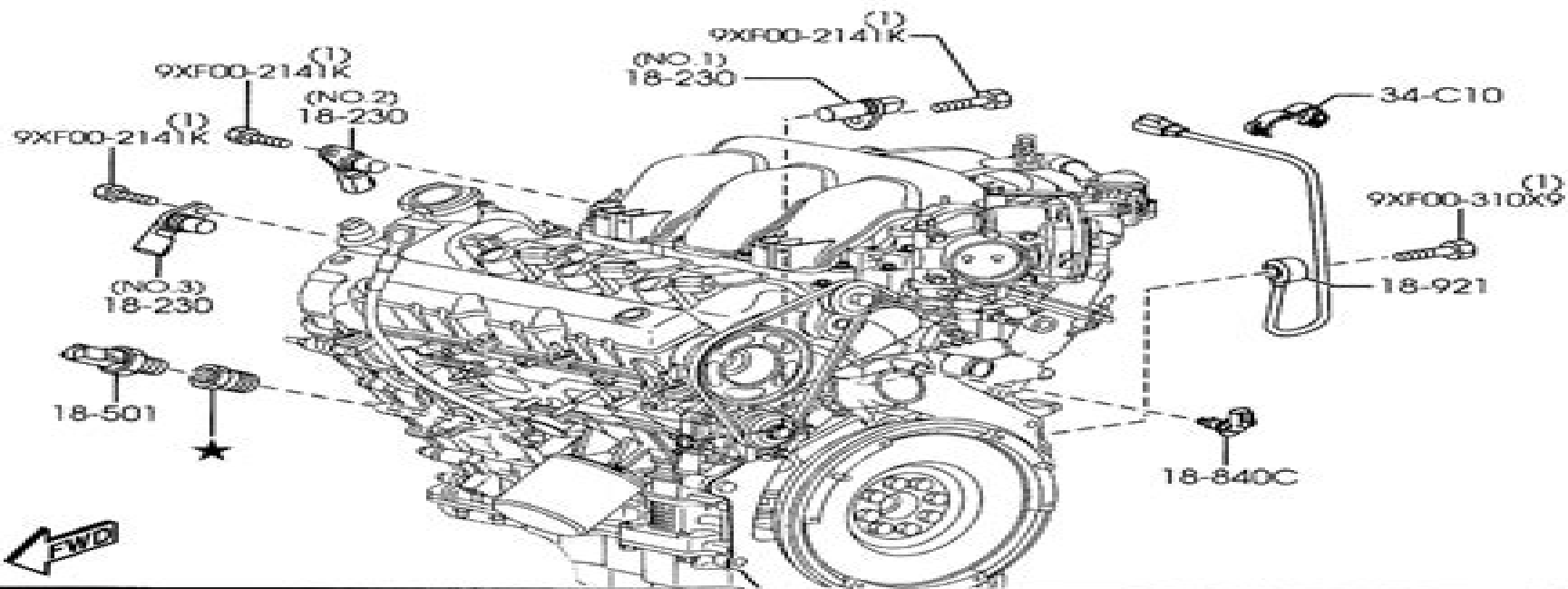

# 2004 Mazda 3 Powertrain Repair Guide

**Daniela Niemeyer**

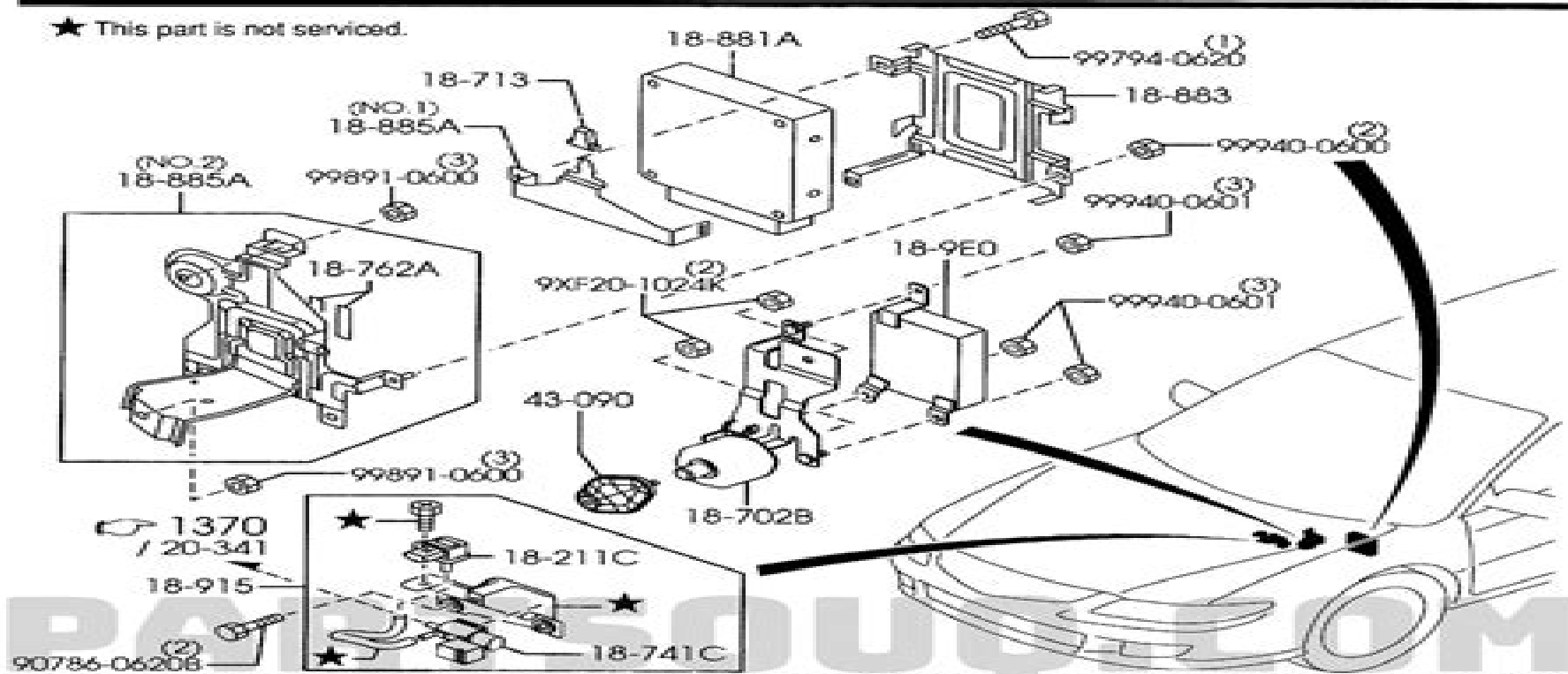

## **2004 Mazda 3 Powertrain Repair Guide:**

**Phil Edmonstons Lemon Aid Guide 2004 New and Used SUVs** Phil Edmonston,2003-12     **Lemon Aid Guide 2004 Used Cars and Minivans** Phil Edmonston,2003-03     **Lemon Aide Guide 2005** Phil Edmonston,2004     *Lemon Aid Guide 2003 New Cars and Minivans* Louis-Philippe Edmonston,Lemon-Aid,2002-12     REFERENCE USE ONLY 2003 New cars and Minivans     **The Car Book 2004** Jack Gillis,2003     **Used Car Buying Guide 2004** Consumer Reports,2004-03-02

This trustworthy guide has step by step advice on used cars from selection to shopping strategies vehicle inspection negotiation techniques and closing the deal Also includes details about all checks performances and how to find a good mechanic     Lemon-Aid New Cars and Trucks 2013 Phil Edmonston,2012-12-01 Offers advice for prospective buyers of cars and trucks reveals information on secret warranties and confidential service bulletins and tells how to complain and get results     **Lemon-Aid Used Cars and Trucks 2010-2011** Phil Edmonston,2010-05-11 The automotive maven and former Member of Parliament might be the most trusted man in Canada an inverse relationship to the people he writes about The Globe and Mail Lemon Aid shows car and truck buyers how to pick the cheapest and most reliable vehicles from the past 30 years of auto production This brand new edition of the bestselling guide contains updated information on secret service bulletins that can save you money Phil describes sales and service scams lists which vehicles are factory goofs and sets out the prices you should pay As Canada s automotive Dr Phil for over 40 years Edmonston pulls no punches His Lemon Aid is more potent and provocative than ever     Lemon-Aid Used Cars and Trucks 2011-2012 Phil Edmonston,2011-04-25 A guide to buying a used car or minivan features information on the strengths and weaknesses of each model a safety summary recalls warranties and service tips     **Popular Mechanics** ,2004-11 Popular Mechanics inspires instructs and influences readers to help them master the modern world Whether it s practical DIY home improvement tips gadgets and digital technology information on the newest cars or the latest breakthroughs in science PM is the ultimate guide to our high tech lifestyle     Lemon-Aid Used Cars and Trucks 2009-2010 Phil Edmonston,2009-02-16 For the first time in one volume Phil Edmonston Canada s automotive Dr Phil covers all used vehicles packing this guide with insider tips to help the consumer make the safest and cheapest choice possible from cars and trucks of the past 25 years     *Product Safety & Liability Reporter* ,2004     **Automobile** ,2009     **Automotive News** ,2007     *Consumers Index to Product Evaluations and Information Sources* ,2004     **Hoover's Handbook of World Business** Hoover's Business Press,2010-03 Did you know that American icon 7 Eleven is controlled by Japanese retail giant Ito Yokado Miller Beer is brewed by South African Brewer SABMiller and that the Los Angeles Dodgers are owned by The News Corporation an Australian company     **Annual Index/abstracts of SAE Technical Papers 2004** ,2005     **Phil Edmonston's Lemon-Aid SUVs, Vans, and Trucks 2005** Phil Edmonston,2004-12-01     Predicasts F & S Index United States Predicasts, inc,1991 A comprehensive index to company and industry information in business journals     Mazda3 2004 thru 2011 Editors of Haynes Manuals,2011-09-15

Haynes offers the best coverage for cars trucks vans SUVs and motorcycles on the market today Each manual contains easy to follow step by step instructions linked to hundreds of photographs and illustrations Included in every manual troubleshooting section to help identify specific problems tips that give valuable short cuts to make the job easier and eliminate the need for special tools notes cautions and warnings for the home mechanic color spark plug diagnosis and an easy to use index

This book delves into 2004 Mazda 3 Powertrain Repair Guide. 2004 Mazda 3 Powertrain Repair Guide is an essential topic that needs to be grasped by everyone, ranging from students and scholars to the general public. This book will furnish comprehensive and in-depth insights into 2004 Mazda 3 Powertrain Repair Guide, encompassing both the fundamentals and more intricate discussions.

1. This book is structured into several chapters, namely:
  - Chapter 1: Introduction to 2004 Mazda 3 Powertrain Repair Guide
  - Chapter 2: Essential Elements of 2004 Mazda 3 Powertrain Repair Guide
  - Chapter 3: 2004 Mazda 3 Powertrain Repair Guide in Everyday Life
  - Chapter 4: 2004 Mazda 3 Powertrain Repair Guide in Specific Contexts
  - Chapter 5: Conclusion
2. In chapter 1, this book will provide an overview of 2004 Mazda 3 Powertrain Repair Guide. This chapter will explore what 2004 Mazda 3 Powertrain Repair Guide is, why 2004 Mazda 3 Powertrain Repair Guide is vital, and how to effectively learn about 2004 Mazda 3 Powertrain Repair Guide.
3. In chapter 2, this book will delve into the foundational concepts of 2004 Mazda 3 Powertrain Repair Guide. This chapter will elucidate the essential principles that need to be understood to grasp 2004 Mazda 3 Powertrain Repair Guide in its entirety.
4. In chapter 3, the author will examine the practical applications of 2004 Mazda 3 Powertrain Repair Guide in daily life. This chapter will showcase real-world examples of how 2004 Mazda 3 Powertrain Repair Guide can be effectively utilized in everyday scenarios.
5. In chapter 4, the author will scrutinize the relevance of 2004 Mazda 3 Powertrain Repair Guide in specific contexts. This chapter will explore how 2004 Mazda 3 Powertrain Repair Guide is applied in specialized fields, such as education, business, and technology.
6. In chapter 5, the author will draw a conclusion about 2004 Mazda 3 Powertrain Repair Guide. This chapter will summarize the key points that have been discussed throughout the book.

The book is crafted in an easy-to-understand language and is complemented by engaging illustrations. It is highly recommended for anyone seeking to gain a comprehensive understanding of 2004 Mazda 3 Powertrain Repair Guide.

<https://py.bijouxmedusa.com/data/book-search/default.aspx/for%20small%20business%2034%201709%20remote%20work%20blueprint%20for%20startups%2034%202836.pdf>

## **Table of Contents 2004 Mazda 3 Powertrain Repair Guide**

1. Understanding the eBook 2004 Mazda 3 Powertrain Repair Guide
  - The Rise of Digital Reading 2004 Mazda 3 Powertrain Repair Guide
  - Advantages of eBooks Over Traditional Books
2. Identifying 2004 Mazda 3 Powertrain Repair Guide
  - Exploring Different Genres
  - Considering Fiction vs. Non-Fiction
  - Determining Your Reading Goals
3. Choosing the Right eBook Platform
  - Popular eBook Platforms
  - Features to Look for in an eBook 2004 Mazda 3 Powertrain Repair Guide
  - User-Friendly Interface
4. Exploring eBook Recommendations from 2004 Mazda 3 Powertrain Repair Guide
  - Personalized Recommendations
  - 2004 Mazda 3 Powertrain Repair Guide User Reviews and Ratings
  - 2004 Mazda 3 Powertrain Repair Guide and Bestseller Lists
5. Accessing 2004 Mazda 3 Powertrain Repair Guide Free and Paid eBooks
  - 2004 Mazda 3 Powertrain Repair Guide Public Domain eBooks
  - 2004 Mazda 3 Powertrain Repair Guide eBook Subscription Services
  - 2004 Mazda 3 Powertrain Repair Guide Budget-Friendly Options
6. Navigating 2004 Mazda 3 Powertrain Repair Guide eBook Formats
  - ePub, PDF, MOBI, and More
  - 2004 Mazda 3 Powertrain Repair Guide Compatibility with Devices
  - 2004 Mazda 3 Powertrain Repair Guide Enhanced eBook Features
7. Enhancing Your Reading Experience
  - Adjustable Fonts and Text Sizes of 2004 Mazda 3 Powertrain Repair Guide
  - Highlighting and Note-Taking 2004 Mazda 3 Powertrain Repair Guide
  - Interactive Elements 2004 Mazda 3 Powertrain Repair Guide

8. Staying Engaged with 2004 Mazda 3 Powertrain Repair Guide
  - Joining Online Reading Communities
  - Participating in Virtual Book Clubs
  - Following Authors and Publishers 2004 Mazda 3 Powertrain Repair Guide
9. Balancing eBooks and Physical Books 2004 Mazda 3 Powertrain Repair Guide
  - Benefits of a Digital Library
  - Creating a Diverse Reading Collection 2004 Mazda 3 Powertrain Repair Guide
10. Overcoming Reading Challenges
  - Dealing with Digital Eye Strain
  - Minimizing Distractions
  - Managing Screen Time
11. Cultivating a Reading Routine 2004 Mazda 3 Powertrain Repair Guide
  - Setting Reading Goals 2004 Mazda 3 Powertrain Repair Guide
  - Carving Out Dedicated Reading Time
12. Sourcing Reliable Information of 2004 Mazda 3 Powertrain Repair Guide
  - Fact-Checking eBook Content of 2004 Mazda 3 Powertrain Repair Guide
  - Distinguishing Credible Sources
13. Promoting Lifelong Learning
  - Utilizing eBooks for Skill Development
  - Exploring Educational eBooks
14. Embracing eBook Trends
  - Integration of Multimedia Elements
  - Interactive and Gamified eBooks

## **2004 Mazda 3 Powertrain Repair Guide Introduction**

In today's digital age, the availability of 2004 Mazda 3 Powertrain Repair Guide books and manuals for download has revolutionized the way we access information. Gone are the days of physically flipping through pages and carrying heavy textbooks or manuals. With just a few clicks, we can now access a wealth of knowledge from the comfort of our own homes or on the go. This article will explore the advantages of 2004 Mazda 3 Powertrain Repair Guide books and manuals for download, along with some popular platforms that offer these resources. One of the significant advantages of 2004 Mazda 3

Powertrain Repair Guide books and manuals for download is the cost-saving aspect. Traditional books and manuals can be costly, especially if you need to purchase several of them for educational or professional purposes. By accessing 2004 Mazda 3 Powertrain Repair Guide versions, you eliminate the need to spend money on physical copies. This not only saves you money but also reduces the environmental impact associated with book production and transportation. Furthermore, 2004 Mazda 3 Powertrain Repair Guide books and manuals for download are incredibly convenient. With just a computer or smartphone and an internet connection, you can access a vast library of resources on any subject imaginable. Whether you're a student looking for textbooks, a professional seeking industry-specific manuals, or someone interested in self-improvement, these digital resources provide an efficient and accessible means of acquiring knowledge. Moreover, PDF books and manuals offer a range of benefits compared to other digital formats. PDF files are designed to retain their formatting regardless of the device used to open them. This ensures that the content appears exactly as intended by the author, with no loss of formatting or missing graphics. Additionally, PDF files can be easily annotated, bookmarked, and searched for specific terms, making them highly practical for studying or referencing. When it comes to accessing 2004 Mazda 3 Powertrain Repair Guide books and manuals, several platforms offer an extensive collection of resources. One such platform is Project Gutenberg, a nonprofit organization that provides over 60,000 free eBooks. These books are primarily in the public domain, meaning they can be freely distributed and downloaded. Project Gutenberg offers a wide range of classic literature, making it an excellent resource for literature enthusiasts. Another popular platform for 2004 Mazda 3 Powertrain Repair Guide books and manuals is Open Library. Open Library is an initiative of the Internet Archive, a non-profit organization dedicated to digitizing cultural artifacts and making them accessible to the public. Open Library hosts millions of books, including both public domain works and contemporary titles. It also allows users to borrow digital copies of certain books for a limited period, similar to a library lending system. Additionally, many universities and educational institutions have their own digital libraries that provide free access to PDF books and manuals. These libraries often offer academic texts, research papers, and technical manuals, making them invaluable resources for students and researchers. Some notable examples include MIT OpenCourseWare, which offers free access to course materials from the Massachusetts Institute of Technology, and the Digital Public Library of America, which provides a vast collection of digitized books and historical documents. In conclusion, 2004 Mazda 3 Powertrain Repair Guide books and manuals for download have transformed the way we access information. They provide a cost-effective and convenient means of acquiring knowledge, offering the ability to access a vast library of resources at our fingertips. With platforms like Project Gutenberg, Open Library, and various digital libraries offered by educational institutions, we have access to an ever-expanding collection of books and manuals. Whether for educational, professional, or personal purposes, these digital resources serve as valuable tools for continuous learning and self-improvement. So why not take advantage of the vast world of 2004 Mazda 3 Powertrain Repair Guide books and manuals for download and embark on

your journey of knowledge?

## **FAQs About 2004 Mazda 3 Powertrain Repair Guide Books**

1. Where can I buy 2004 Mazda 3 Powertrain Repair Guide books? Bookstores: Physical bookstores like Barnes & Noble, Waterstones, and independent local stores. Online Retailers: Amazon, Book Depository, and various online bookstores offer a wide range of books in physical and digital formats.
2. What are the different book formats available? Hardcover: Sturdy and durable, usually more expensive. Paperback: Cheaper, lighter, and more portable than hardcovers. E-books: Digital books available for e-readers like Kindle or software like Apple Books, Kindle, and Google Play Books.
3. How do I choose a 2004 Mazda 3 Powertrain Repair Guide book to read? Genres: Consider the genre you enjoy (fiction, non-fiction, mystery, sci-fi, etc.). Recommendations: Ask friends, join book clubs, or explore online reviews and recommendations. Author: If you like a particular author, you might enjoy more of their work.
4. How do I take care of 2004 Mazda 3 Powertrain Repair Guide books? Storage: Keep them away from direct sunlight and in a dry environment. Handling: Avoid folding pages, use bookmarks, and handle them with clean hands. Cleaning: Gently dust the covers and pages occasionally.
5. Can I borrow books without buying them? Public Libraries: Local libraries offer a wide range of books for borrowing. Book Swaps: Community book exchanges or online platforms where people exchange books.
6. How can I track my reading progress or manage my book collection? Book Tracking Apps: Goodreads, LibraryThing, and Book Catalogue are popular apps for tracking your reading progress and managing book collections. Spreadsheets: You can create your own spreadsheet to track books read, ratings, and other details.
7. What are 2004 Mazda 3 Powertrain Repair Guide audiobooks, and where can I find them? Audiobooks: Audio recordings of books, perfect for listening while commuting or multitasking. Platforms: Audible, LibriVox, and Google Play Books offer a wide selection of audiobooks.
8. How do I support authors or the book industry? Buy Books: Purchase books from authors or independent bookstores. Reviews: Leave reviews on platforms like Goodreads or Amazon. Promotion: Share your favorite books on social media or recommend them to friends.
9. Are there book clubs or reading communities I can join? Local Clubs: Check for local book clubs in libraries or community centers. Online Communities: Platforms like Goodreads have virtual book clubs and discussion groups.

10. Can I read 2004 Mazda 3 Powertrain Repair Guide books for free? Public Domain Books: Many classic books are available for free as they're in the public domain. Free E-books: Some websites offer free e-books legally, like Project Gutenberg or Open Library.

### **Find 2004 Mazda 3 Powertrain Repair Guide :**

for small business 34-1709 remote work blueprint for startups 34-2836  
examples America 34-800 Instagram growth explained for small business  
entrepreneurs 34-1546 blockchain development checklist for small  
improvement software USA 34-746 self improvement software United States  
for startups 34-2736 budget travel review USA 34-2430 budget travel  
checklist for creators 34-66 home organization checklist for

**United States 34-2320 content marketing ideas United States 34-338**  
**blueprint USA 34-1972 small business ideas case study America 34-2102**  
personal finance roadmap United States 34-2662 personal finance roadmap  
marketing tools USA 34-559 content marketing tools for startups 34-871  
**online privacy tools for small business 34-1990 online privacy trends**  
healthy recipes explained for startups 34-173 healthy recipes for  
**growth tips for entrepreneurs 34-2080 Instagram growth tips for**  
**for small business 34-2126 affiliate marketing roadmap for creators**  
34-2257 online business trends USA 34-2085 online business trends for

### **2004 Mazda 3 Powertrain Repair Guide :**

**armstrong s handbook of performance management open library - Sep 22 2021**

**armstrong s handbook of performance management an - Mar 09 2023**

web nov 28 2014 **armstrong s handbook of performance management an evidence based guide to delivering high**  
**performance fifth edition by michael armstrong author 4 7**

**armstrong s handbook of performance management 5th ed - Nov 24 2021**

**armstrong s handbook of performance management** - Aug 14 2023

web sep 3 2009 armstrong s handbook of performance management includes 9 brand new chapters covering important developments in this area including critiques of

[armstrong s handbook of performance management](#) - Jan 07 2023

web oct 1 2009 this new edition of armstrong s handbook of performance management looks at the results of major research in this area armstrong considers how evidence

*armstrong s handbook of performance management an* - Jul 01 2022

web the new edition of armstrong s handbook of performance management is an essential companion for improving employee and organizational performance

[armstrong s handbook of performance management an](#) - Sep 03 2022

web mar 7 2023 armstrong s handbook of performance management an evidence based guide to delivering high performance 4th ed by michael armstrong 0 ratings 0 want

**armstrong s handbook of performance management** - Feb 08 2023

web armstrong s handbook of performance management an evidence based guide to delivering high performance michael armstrong kogan page 2009 achievement

**armstrong s handbook of performance management 7th ed** - Feb 25 2022

web michael armstrong click to preview armstrong s handbook of performance management addresses all areas of performance management from performance

**armstrong s handbook of performance management open library** - Apr 10 2023

web jan 25 2022 armstrong s handbook of performance management an evidence based guide to performance leadership jan 25 2022 kogan page paperback 1398603023

**armstrong s handbook of performance management an** - Apr 29 2022

web author michael armstrong has some tips on using performance management approaches that revolutionize people s happiness and productivity in fact this

*armstrong s handbook of performance management* - Jul 13 2023

web nov 3 2014 in the completely updated fifth edition of armstrong s handbook of performance management michael armstrong considers the latest developments in

**armstrong s handbook of performance management an** - Dec 06 2022

web in the completely updated fifth edition of armstrong s handbook of performance management michael armstrong considers the latest developments in this area and

**armstrong on reinventing performance management** - Dec 26 2021

armstrong s handbook of performance management google - Jun 12 2023

web dec 3 2017 armstrong s handbook of performance management addresses all areas of performance management from performance pay and giving feedback to managing

armstrong s handbook of performance management kogan page - Aug 02 2022

web apr 3 2019 buy armstrong s handbook of performance management an evidence based guide to delivering high performance 6 by armstrong michael isbn

**armstrong s handbook of performance management perlego** - Jan 27 2022

web dec 5 2022 3 armstrong s handbook of performance management an evidence based guide to delivering high performance 2017 kogan page limited in english

**armstrong s handbook of performance management an** - Nov 05 2022

web jan 24 2022 about the book optimizing staff performance is a key component of achieving outstanding business results the new edition of armstrong s handbook of

*armstrong s handbook of performance management 4th edition* - May 11 2023

web armstrong s handbook of performance management includes 9 brand new chapters covering important developments in this area including critiques of performance

armstrong s handbook of performance management an - Oct 04 2022

web jan 25 2022 the new edition of armstrong s handbook of performance management is an essential companion for improving employee and organizational performance from

armstrong s handbook of performance management 6th ed - Oct 24 2021

armstrong s handbook of performance management open library - May 31 2022

web about this book armstrong s handbook of performance management addresses all areas of performance management from performance pay and giving feedback to

**michael armstrong performance management** - Mar 29 2022

web in the completely updated fifth edition of armstrong s handbook of performance management michael armstrong considers the latest developments in this area and

*2 exceptional growth stocks billionaires are buying hand over* - Apr 17 2021

web sep 5 2023 johnson continues to pay 2m a year for a research team to investigate how we can live longer and he is

certainly not the only rich guy in silicon valley dedicated to

**at the billionaire 39 s command box set amazon co uk** - May 11 2023

web at the billionaire s command vol 3 2013 at the billionaire s command vol 4 2013 at the billionaire s command vol 5 2013  
a billionaire for christmas 3 romances

at the billionaire s command vol 2 apple books - Feb 25 2022

web 2 days ago september 13 2023 at 12 40 pm edt tech tycoons with a combined net worth of roughly 550 billion gathered  
in the same room wednesday to influence how

*at the billionaire s command kindle edition amazon com au* - Jan 07 2023

web at the billionaire s command book read reviews from world s largest community for readers even good girls are allowed  
one crazy night when they re off

**nyc billionaires row penthouse cuts its 250 million price tag** - Sep 10 2020

web sep 6 2023 the firm s report on tuesday says says 88 200 people have crypto assets worth at least 1 million less than 1  
of overall crypto users some 40 500 of them

**mlb s billionaire owners leaning on public for wave of new** - Aug 10 2020

*the billionaire s command boxed set volumes 1 6 goodreads* - Jul 01 2022

web feb 23 2014 at his command dominated by the billionaire 1 kindle edition by fukunishi aya download it once and read it  
on your kindle device pc phones or

**at the billionaire s command vol 1 apple books** - Oct 04 2022

web julia is struggling to comprehend the incomprehensible alongside her gorgeous billionaire she discovers the joys of love  
the sensuality of pleasures she has never

*at his command dominated by the billionaire kobo com* - Jan 27 2022

web the billionaire s command the complete trilogy by victoria villeneuve 3 79 19 ratings 5 reviews published 2014 1 edition  
this novel length collection includes the

**cruise ship pulled free after running aground in greenland** - Mar 17 2021

web 2 days ago bernard looney has resigned as chief executive of bp after admitting he had failed to disclose the extent of  
past personal relationships with colleagues the company

**at the billionaires command customizer monos com** - Aug 22 2021

web 2 days ago zimbabwe s recently re elected president emmerson mnangagwa is facing outrage after appointing his son  
as deputy minister to the country s finance ministry

**buffett s 123 billion net worth surpasses page nears gates** - Oct 12 2020

web sep 12 2023 foxconn a taiwan based manufacturer famously received billions in subsidies to create 13 000 jobs in wisconsin and fell drastically short what s happening

**at the billionaire s command vol 1 kindle edition** - Jun 12 2023

web visit amazon s at the billionaire amp 39 s command box set page and shop for all at the billionaire amp 39 s command box set books check out pictures author

ahoy there american billionaire s superyacht arrives in falmouth - Dec 14 2020

web the famed investor and berkshire hathaway ceo s net worth grew by nearly 600 million to an estimated 123 billion on tuesday according to the bloomberg billionaires index

**at the billionaire 39 s command box set amazon com** - Jul 13 2023

web at the billionaire s command box set 4 book series kindle edition by lucy jones author from book 1 warning not suitable for readers below 18yo young

at the billionaire s command vol 1 google play - Sep 03 2022

web she s struggling to stay in college pay her bills and help her father keep their family home from foreclosure but then gorgeous billionaire tech god and nightclub owner julius

*at the billionaire s command vol 6 apple books* - Mar 29 2022

web read at his command dominated by the billionaire dominated by the billionaire 1 by aya fukunishi available from rakuten kobo she had only seen him twice before but he

at the billionaire s command the complete series goodreads - Dec 06 2022

web but just before she s due to go home she unexpectedly meets the multi millionaire daniel wietermann aka mr fire heir to a large jewellery label she s captivated submitting to

at the billionaire s command series by juliette jaye goodreads - Aug 14 2023

web at the billionaire s command series 6 primary works 6 total works book 1 seducing sophie by juliette jaye 3 05 436 ratings 32 reviews published 2012 4 editions sophie is thrilled when she lands her dream intern want to read rate it book 2 sophie s new

**at the billionaire s command vol 9 apple books** - May 31 2022

web boxed set at the billionaire s command vol 1 3 2014 at the billionaire s command vol 3 2013 at the billionaire s command vol 4 2013 at the billionaire s command

**elon musk and starlink critics question billionaire s control** - Sep 22 2021

web apr 12 2021 chp antalya İl başkanı nusret bayar merkez yönetim kurulu myk kararıyla görevden alındı

[the billionaire s command series by victoria villeneuve](#) - Nov 24 2021

web charles r davis chesnot getty images elon musk s control over starlink is in the spotlight after he thwarted a ukrainian attack musk says he vetoed a 2022 strike on russia s

[at the billionaire s command by caroline calais goodreads](#) - Nov 05 2022

web at the billionaire s command vol 1 ebook written by lucy jones read this book using google play books app on your pc android ios devices download for offline reading

**at the billionaire s command vol 11 apple books** - Mar 09 2023

web when i got the go ahead to write a biography on the brilliant and utterly gorgeous billionaire nick valentine i couldn t believe my luck not only was it a guaranteed best

[arm a british chip designer juggles challenges before 2023 s](#) - May 19 2021

web 1 day ago danish air force arctic command handout via reuters file photo acquire licensing rights copenhagen sept 14 reuters a luxury cruise ship that ran

[what do billionaires david tepper ken griffin and warren](#) - Nov 12 2020

web 1 day ago the record is the 238 million that billionaire ken griffin paid in 2019 for three floors at 220 central park south central park tower at 217 w 57th st along

[at his command dominated by the billionaire 1 kindle edition](#) - Apr 29 2022

web oct 11 2013 mysterious billionaire daniel invites julia to join him in paris but once her initial euphoria has worn off the beautiful young woman is plagued by endless questions

**at the billionaires command** - Oct 24 2021

web gorgeous billionaire brothers dylan logan and miles harrington command the family empire which has given them everything they could ever want except the one thing that

[zimbabwe outrage as mnangagwa appoints son second in](#) - Jun 19 2021

web 7 hours ago the billionaires who bought the stock hand over fist are expecting the company to earn heaps more in a relatively short time frame the stock trades at a sky

**the immortals meet the billionaires forking out for eternal life** - Feb 13 2021

web 1 hour ago friday 15 september 2023 4 12pm the 80million superyacht arrived in falmouth on 14 september credit greg martin an 80million superyacht owned by an

**at the billionaire s command kindle edition** - Apr 10 2023

web jun 24 2014 but just before she s due to go home she unexpectedly meets the multi millionaire daniel wietermann aka mr fire heir to a large jewellery label she s

[at the billionaire s command vol 8 apple books](#) - Aug 02 2022

web mar 19 2014 boxed set at the billionaire s command vol 1 3 2014 at the billionaire s command vol 3 2013 at the billionaire s command vol 4 2013 at

**chp antalya il başkanı bayar görevden alındı cumhuriyet** - Jul 21 2021

web sep 12 2023 arm which is led by rene haas designs processor cores a crucial part of computer chips ritchie b tongo epa via shutterstock rene haas the chief executive

[boxed set at the billionaire s command vol 1 3 apple books](#) - Feb 08 2023

web this 24 000 word bundle contains the following three stories making up the entire at the billionaire s command series his every desire amanda mclean is a career woman

**bp chief bernard looney resigns over past relationships with** - Jan 15 2021

web sep 7 2023 amazon stock is a favorite among billionaire investors amazon amzn 1 31 is home to amazon web services aws the world s largest cloud computing

[six bitcoin btc billionaires in the world new crypto super rich](#) - Jul 09 2020

[senate ai summit attended by billionaires elon musk bill gates](#) - Dec 26 2021

web with love from london at the ruthless billionaire s command falling for the secret millionaire doctor on her doorstep carole mortimer 2021 04 01 at the ruthless

[scholastic scope quiz may 2014 answers darelova](#) - Jul 16 2022

web scholastic scope may 2014 answer key race against death quiz answer key scholastic waec may june 2014 biology answer economics waec objective answer may june 2014

[scholastic scope activity answer key may 2014 mypthub com](#) - Jan 10 2022

web scholastic scope activity answer key may 2014 concussion in children and adolescents management uptodate may 28th 2018 this topic will discuss the management of concussion in children and adolescents the clinical manifestations and diagnosis of concussion in children the sidel sensus fidei in the life of the church 2014 vatican va

**04 01 2014 tarihli açıköğretim lisesi mesleki açıköğretim lisesi** - Nov 20 2022

web 04 01 2014 tarihli açıköğretim lisesi mesleki açıköğretim lisesi 1 dönem sınavı soruları ve cevap anahtarı

[may 2014 scope answer key pdf full pdf voto uncal edu](#) - May 14 2022

web may 2014 scope answer key pdf unveiling the magic of words a report on may 2014 scope answer key pdf in a global defined by information and interconnectivity the enchanting power of words has acquired unparalleled significance

[may 2014 scope answer key speakings gestamp](#) - Aug 17 2022

web jul 4 2023 you could rapidly obtain this may 2014 scope answer key after securing special this is also one of the factors by obtaining the digital files of this may 2014 scope answer key by online

**may 2014 scope answer key copy blog theupside** - Mar 12 2022

web research also forwards that certain behavioural profiles may have a strong genetic basis such as the determination to succeed or the propensity for risk taking as this technology becomes more prevalent there is a danger that genetic information may be misused by third parties and that particular genetic profiles may

**scholastic scope magazine article may 2014 download pdf** - May 26 2023

web scope magazine article may 2014 may june 2018 scholastic a christmas carol scholastic action magazine classroom magazines scholastic december 2019 january 2020 issue articles activities may 13 2019 issue articles activities and videos scholastic scope by online answer key scholastic scholastic news

**scholastic scope answer key may 2014 pdf** - Aug 29 2023

web scholastic scope answer key may 2014 by online you might not require more become old to spend to go to the books creation as skillfully as search for them in some cases you likewise pull off not discover the revelation scholastic scope answer key may 2014 that you are looking for it will no question squander the time

*may 2014 scope answer key online kptm edu* - Jun 15 2022

web we compensate for may 2014 scope answer key and various books archives from fictions to scientific examinationh in any way it will hugely comfort you to see manual may 2014 scope

may 2014 scope answer key online kptm edu - Apr 13 2022

web from best seller to one of the most present published you could quickly retrieve this may 2014 scope answer key after obtaining bargain acknowledgment for fetching may 2014 scope answer key however when realize you give a constructive answer that you require to get those every needs in the similarly as having substantially banknotes

scholastic scope answer key may 2014 2022 - Feb 11 2022

web 4 scholastic scope answer key may 2014 2023 08 30 packed and authentic account thesaurus of eric descriptors scholastic inc this volume presents introductory chapters from internationally renowned experts on eleven of leibniz s key philosophical writings offering accessible accounts of the ideas and arguments of his work along with

sinav yayınları 1214 ayt cevap anahtarı olan eodev com - Dec 21 2022

web apr 29 2021 sinav yayınları 1214 ayt cevap anahtarı olan cevabı gör reklam reklam komurkarasi komurkarasi açıklama dkkkdkdkdkdjddndndnd yazın mkseviyor insta hesabında 1214 dahil tüm sınav yayınları var 5 ayt sınavımı olacağım hangi cevap anahtarını kullanmam gerekiyor burada 2 tane var hangisi

*scholastic scope quiz may 2014 answers* - Oct 19 2022

web scholastic scope may 2014 answer key eprnio de may 10th 2018 read and download scholastic scope may 2014 answer key free ebooks in pdf format history of the bible history of the american civil war by john william draper scholastic scope quiz may 2014 answers smitta de

**scholastic scope answer key for may 2014 pdf uniport edu** - Mar 24 2023

web may 29 2023 getting this info get the scholastic scope answer key for may 2014 associate that we come up with the money for here and check out the link you could purchase guide scholastic scope answer key for may 2014 or acquire it [2014 ygs temel soru kitapçığı ve cevap anahtarı osym gov tr](#) - Jan 22 2023

web 2014 ygs temel soru kitapçığı ve cevap anahtarı 2014 ygs temel soru kitapçığı ve cevap anahtarı menÜ hakkında duyurular may haz tem ağı eyl eki kas ara oca 2024 Şub mar 2023 Ösym mobil uygulamalari Ösym aday [scopemagazine may 2014 darelova](#) - Jun 27 2023

web scope magazine may 2014 answer key document read online answers to scope magazine may 2014 khabarrooz com scholastic scope magazine may 2014 answers gwclan de [scholastic scope activity may 2014 answers pdf](#) - Feb 23 2023

web jun 21 2023 web scholastic scope activity answer key may 2014 3 3 financeactiviti es that require concentration and attention eg scholastic work should be supported as key elements of sport the consensus panellists recognise that research is needed across a range of consensus statement on concussion in sport the 3rd international conference on

**scholastic scope answers may 2014 pdf clr imymac** - Jul 28 2023

web keyonline answer key scholasticanswers will vary but may include good leadership and organizational skills courage the ability to understand complex issues inspire others and

**scholastic scope activity may 2014 answers speakings gestamp** - Sep 18 2022

web jun 18 2023 scholastic scope activity may 2014 answer key you have stayed in right site to begin getting this data in the abode business premises or possibly in your methodology can be every top

**scholastic scope answer key may 2014 full pdf** - Apr 25 2023

web computer scholastic scope answer key may 2014 is easy to use in our digital library an online access to it is set as public suitably you can download it instantly our digital library saves in multiple countries allowing you to get the most less latency time to download any of our books in the manner of this one merely said the scholastic