

1997 J/70-F & ECT (4A-16)

20V

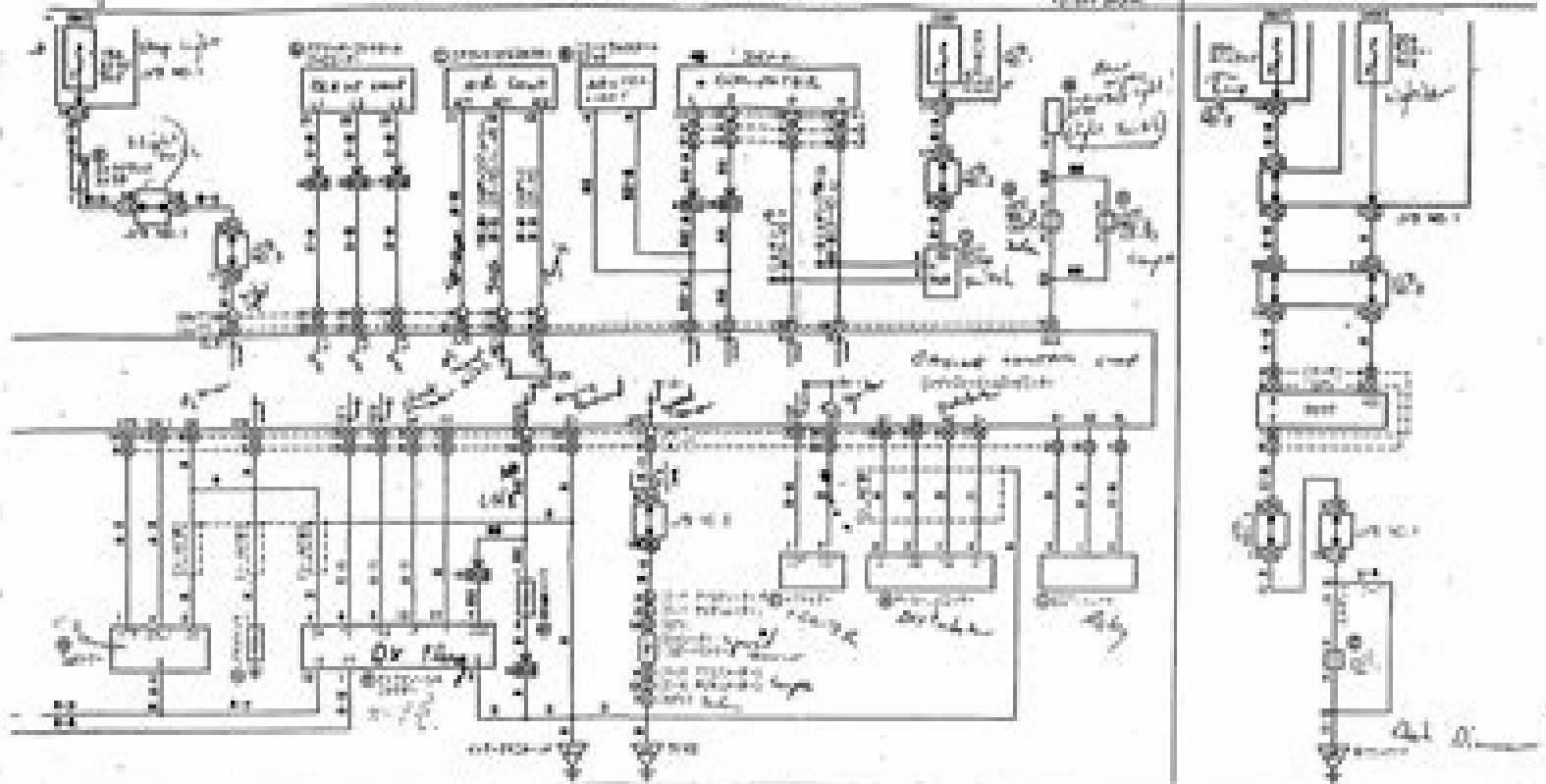

20V

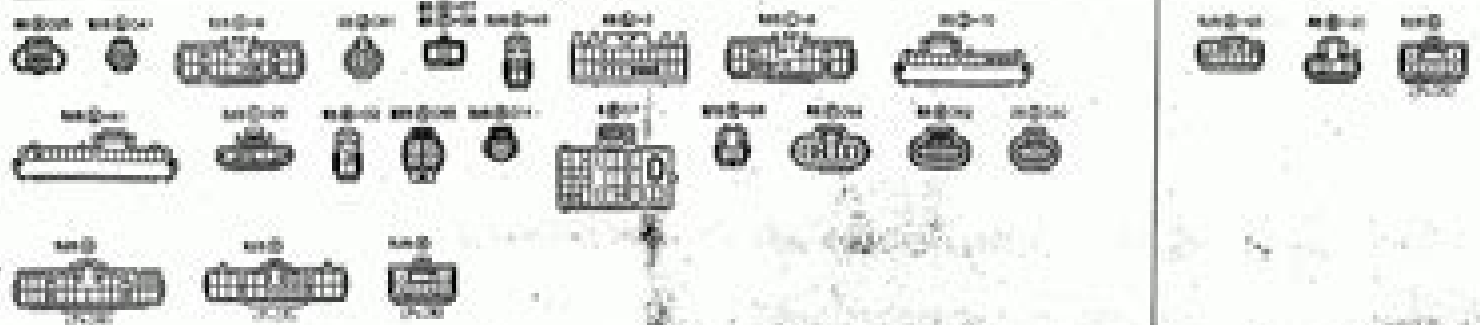

1997 J/70-F & ECT (4A-16)

4efte Manual

Penton Staff



4efte Manual:

Allis-Chalmers Shop Manual Ac-202 (I&T Shop Service Manuals/Ac-202) Penton Staff,2000-05-24 Model D 19 Models 180 185 190 190XT 200 7000 Models D 21 D 21 Series II Two Ten Two Twenty Models 7010 7020 7030 7040 7045 7050 7060 7080 Gas and diesel Diesel Toyota 4A-F, 4A-GE Engine Repair Manual , **Toyota 4A-FE, 4A-GE Engine Repair Manual** ,1994 **The Hollander Interchange Manual** Hollander,Hollander Company,2001-08-01 **2007 Import Diagnostic Trouble Code Manual (1994-2007)** Autodata,2006-11 Model year coverage for the Import DTC Manual is 1994 2007 The manuals features domestic diagnostic trouble codes and list the probable cause of each code The manual provides MIL Codes OBD Codes and Fault locations Code retrieval techniques are described using concise text and clear illustrations in separate sections for each model Instructions for retrieval and erasure of trouble codes are provided as well as data link connector locations All data is based on OEM information The information is available on CD CDs contain both English and Spanish languages **Today's Technician: Manual Transmissions and Transaxles Classroom Manual and Shop Manual** Jack Erjavec,Michael Ronan,Justin Blevins,2026-01-16 Gear up for success with Today s Technician Manual Transmissions and Transaxles Classroom Manual and Shop Manual 8th Edition This proven practical guide includes easy to understand information on a range of must know topics including transmission system and subsystem components shop safety basics dual clutch systems limited slip differential designs all wheel drive systems and six speed transmissions The text includes a Classroom Manual reviewing every topic for Manual Drive Train and Axles and a hands on Shop Manual with photos and detailed job sheets so you ll know exactly what to expect with performing service and repair tasks based on the latest MLR AST and MAST task lists The text as well as end of chapter questions prepare you for the ASE certification exam Chapter objectives are clearly laid out and match chapter headings for both the classroom and shop manuals **Ford Speed Manual** Bill Fisher,2007-05-01 Reprint of the original 1952 edition is still viable and is filled with useful information for today s enthusiast Because most Ford owners are interested in hopping up their engines for maximum performance with minimum expense This book provides basic information on the engines and what the engine is capable of doing **The Hollander Interchange Manual** Hollander,2000-10-01 *NATEF Standards Job Sheet - A3 Manual Transmissions* Jack Erjavec,Delmar Thomson Learning,Thomson Delmar Learning,2002-02-14 New from today s leading automotive education publisher each of our eight NATEF National Automotive Technicians Education Foundation Standards Job Sheets workbooks has been thoughtfully designed to assist users in gaining valuable job preparedness skills and mastering specific technical competencies required for success as a professional automotive technician Ideal for use as a stand alone item or with any comprehensive or topic specific automotive text the entire series is based on current NATEF standards and consists of individual books for each of the following areas Engine Repair Automatic Transmissions Transaxles Manual Drive Trains and Axles Suspension and Steering Brakes Electricity Electronics Heating and Air Conditioning and

Engine Performance Central to each manual are well designed and easy to read job sheets each of which contains specific performance based objectives lists of required tools and materials safety precautions plus step by step procedures to lead users to completion of shop activities As they work through each task users are encouraged to conduct tests record measurements make observations and employ critical thinking skills in order to draw conclusions Space for users to make notes concerning problems encountered while working as well as space for instructors to add comments and or grades is also included **Allis Chalmers Shop Manual Models B C CA G RC WC WD +** Editors of Haynes Manuals,1994-12-01 With a Haynes manual you can do it yourself from simple maintenance to basic repairs Haynes writes every book based on a complete teardown of the vehicle where we learn the best ways to do a job and that makes it quicker easier and cheaper for you Haynes books have clear instructions and hundreds of photographs that show each step Whether you are a beginner or a pro you can save big with a Haynes manual This manual features complete coverage for your Allis Chalmers Tractor Models B C CA G RC WC WD covering routine maintenance tune up procedures engine repair cooling and heating air conditioning fuel and exhaust emissions control ignition brakes suspension and steering electrical systems and wiring diagrams

Today's Technician: Manual Transmissions and Transaxles Classroom Manual and Shop Manual, Spiral bound Version Jack Erjavec,Michael Ronan,2015-01-02 Succeed in the course your future career and the ASE A3 Manual Drive Train and Axles certification test with TODAY S TECHNICIAN MANUAL TRANSMISSIONS TRANSAXLES 6e You ll find practical easy to understand coverage of a wide range of must know topics that adhere the 2013 ASE Education Foundation AST MAST program standards including dual clutch systems various limited slip differential designs six speed transmissions safe work practices and more Volume I the Classroom Manual covers every topic on the ASE A3 Manual Drive Train and Axles certification test while Volume II the Shop Manual includes job sheets that get you involved in performing hands on service and repair tasks In addition detailed full color photos show you what to expect when performing a procedure on the job Important Notice Media content referenced within the product description or the product text may not be available in the ebook version *Today's Technician: Manual Transmissions and Transaxles Shop Manual* Jack Erjavec,Michael Ronan,2015-01-02 Succeed in your future career and on the ASE A3 Manual Drive Train and Axles certification test with TODAY S TECHNICIAN MANUAL TRANSMISSIONS TRANSAXLES 6e You ll find practical easy to understand coverage of a wide range of must know topics that adhere the 2013 ASE Education Foundation AST MAST program standards including dual clutch systems various limited slip differential designs six speed transmissions safe work practices and more Volume I covers every topic on the ASE A3 Manual Drive Train and Axles certification test while Volume II includes job sheets that get you involved in performing hands on service and repair tasks In addition detailed full color photos show you what to expect when performing a procedure on the job *Hollander Interchange Manuals* Hollander,2004-09-01 Automotive parts interchange and identification information 2018 Toyota Camry Owner Manual Compatible with OEM Owners Manual,

Factory Glovebox Book Helming,2018-08-20 *Case International Shop Manuals 1190 1290 1390 1490+* Editors of Haynes Manuals,1987-11-01 With a Haynes manual you can do it yourself from simple maintenance to basic repairs Haynes writes every book based on a complete teardown of the vehicle where we learn the best ways to do a job and that makes it quicker easier and cheaper for you Haynes books have clear instructions and hundreds of photographs that show each step Whether you are a beginner or a pro you can save big with a Haynes manual This manual features complete coverage for your Case International Tractor Models 1190 1290 1390 or 1490 covering Routine maintenance Tune up procedures Engine repair Cooling and heating Air conditioning Fuel and exhaust Emissions control Ignition Brakes Suspension and steering Electrical systems and Wiring diagrams **Toyota 4A-GE Engine Emission Control Repair Manual** ,1987 White: Shop Manual W-201 (I & T Shop Service Manuals, W-201) Penton Staff,2000-05-24 Gas models 2 70 Diesel models 2 30 2 35 2 45 2 55 2 62 2 65 2 70 2 75 2 85 2 105 2 135 2 150 2 155 **White: Shop Manual W-201 (I & T Shop Service Manuals, W-201)**

Penton Staff,2000-05-24 Gas models 2 70 Diesel models 2 30 2 35 2 45 2 55 2 62 2 65 2 70 2 75 2 85 2 105 2 135 2 150 2 155

Turbo Hydra-Matic 350 Handbook Ron Sessions,1987-01-01 This clear concise text leads you through every step of the rebuild of your Turbo Hydra matic transmission from removal teardown and inspection to assembly and installation This book also covers transmission identification principles of operation and maintenance troubleshooting and in car repairs It includes heavy duty and high performance modifications coolers high stall converters shift programming kits internal beef ups and more More than 750 photos drawings and charts combine with text give you the most authoritative book of its kind

Allis-Chalmers Shop Manual AC20 AC17 AC25 & AC27 Editors of Haynes Manuals,1989-10-01 With a Haynes manual you can do it yourself from simple maintenance to basic repairs Haynes writes every book based on a complete teardown of the vehicle where we learn the best ways to do a job and that makes it quicker easier and cheaper for you Haynes books have clear instructions and hundreds of photographs that show each step Whether you are a beginner or a pro you can save big with a Haynes manual This manual features complete coverage for your Allis Chambers Tractor Model AC20 AC17 AC25 or AC27 covering routine maintenance tune up procedures engine repair cooling and heating air conditioning fuel and exhaust emissions control ignition brakes suspension and steering electrical systems and wiring diagrams

Embark on a breathtaking journey through nature and adventure with is mesmerizing ebook, **4efte Manual** . This immersive experience, available for download in a PDF format (*), transports you to the heart of natural marvels and thrilling escapades. Download now and let the adventure begin!

https://py.bijouxmedusa.com/public/scholarship/Download_PDFS/Clockwork_Angel_The_Infernal_Devices_Themedore.pdf

Table of Contents 4efte Manual

1. Understanding the eBook 4efte Manual
 - The Rise of Digital Reading 4efte Manual
 - Advantages of eBooks Over Traditional Books
2. Identifying 4efte Manual
 - Exploring Different Genres
 - Considering Fiction vs. Non-Fiction
 - Determining Your Reading Goals
3. Choosing the Right eBook Platform
 - Popular eBook Platforms
 - Features to Look for in an 4efte Manual
 - User-Friendly Interface
4. Exploring eBook Recommendations from 4efte Manual
 - Personalized Recommendations
 - 4efte Manual User Reviews and Ratings
 - 4efte Manual and Bestseller Lists
5. Accessing 4efte Manual Free and Paid eBooks
 - 4efte Manual Public Domain eBooks
 - 4efte Manual eBook Subscription Services
 - 4efte Manual Budget-Friendly Options
6. Navigating 4efte Manual eBook Formats

- ePub, PDF, MOBI, and More
 - 4efte Manual Compatibility with Devices
 - 4efte Manual Enhanced eBook Features
7. Enhancing Your Reading Experience
 - Adjustable Fonts and Text Sizes of 4efte Manual
 - Highlighting and Note-Taking 4efte Manual
 - Interactive Elements 4efte Manual
 8. Staying Engaged with 4efte Manual
 - Joining Online Reading Communities
 - Participating in Virtual Book Clubs
 - Following Authors and Publishers 4efte Manual
 9. Balancing eBooks and Physical Books 4efte Manual
 - Benefits of a Digital Library
 - Creating a Diverse Reading Collection 4efte Manual
 10. Overcoming Reading Challenges
 - Dealing with Digital Eye Strain
 - Minimizing Distractions
 - Managing Screen Time
 11. Cultivating a Reading Routine 4efte Manual
 - Setting Reading Goals 4efte Manual
 - Carving Out Dedicated Reading Time
 12. Sourcing Reliable Information of 4efte Manual
 - Fact-Checking eBook Content of 4efte Manual
 - Distinguishing Credible Sources
 13. Promoting Lifelong Learning
 - Utilizing eBooks for Skill Development
 - Exploring Educational eBooks
 14. Embracing eBook Trends
 - Integration of Multimedia Elements
 - Interactive and Gamified eBooks

4efte Manual Introduction

Free PDF Books and Manuals for Download: Unlocking Knowledge at Your Fingertips In today's fast-paced digital age, obtaining valuable knowledge has become easier than ever. Thanks to the internet, a vast array of books and manuals are now available for free download in PDF format. Whether you are a student, professional, or simply an avid reader, this treasure trove of downloadable resources offers a wealth of information, conveniently accessible anytime, anywhere. The advent of online libraries and platforms dedicated to sharing knowledge has revolutionized the way we consume information. No longer confined to physical libraries or bookstores, readers can now access an extensive collection of digital books and manuals with just a few clicks. These resources, available in PDF, Microsoft Word, and PowerPoint formats, cater to a wide range of interests, including literature, technology, science, history, and much more. One notable platform where you can explore and download free 4efte Manual PDF books and manuals is the internet's largest free library. Hosted online, this catalog compiles a vast assortment of documents, making it a veritable goldmine of knowledge. With its easy-to-use website interface and customizable PDF generator, this platform offers a user-friendly experience, allowing individuals to effortlessly navigate and access the information they seek. The availability of free PDF books and manuals on this platform demonstrates its commitment to democratizing education and empowering individuals with the tools needed to succeed in their chosen fields. It allows anyone, regardless of their background or financial limitations, to expand their horizons and gain insights from experts in various disciplines. One of the most significant advantages of downloading PDF books and manuals lies in their portability. Unlike physical copies, digital books can be stored and carried on a single device, such as a tablet or smartphone, saving valuable space and weight. This convenience makes it possible for readers to have their entire library at their fingertips, whether they are commuting, traveling, or simply enjoying a lazy afternoon at home. Additionally, digital files are easily searchable, enabling readers to locate specific information within seconds. With a few keystrokes, users can search for keywords, topics, or phrases, making research and finding relevant information a breeze. This efficiency saves time and effort, streamlining the learning process and allowing individuals to focus on extracting the information they need. Furthermore, the availability of free PDF books and manuals fosters a culture of continuous learning. By removing financial barriers, more people can access educational resources and pursue lifelong learning, contributing to personal growth and professional development. This democratization of knowledge promotes intellectual curiosity and empowers individuals to become lifelong learners, promoting progress and innovation in various fields. It is worth noting that while accessing free 4efte Manual PDF books and manuals is convenient and cost-effective, it is vital to respect copyright laws and intellectual property rights. Platforms offering free downloads often operate within legal boundaries, ensuring that the materials they provide are either in the public domain or authorized for distribution. By adhering to copyright laws, users can enjoy the benefits of free access to knowledge while supporting the authors and publishers who make these resources available. In

conclusion, the availability of 4efte Manual free PDF books and manuals for download has revolutionized the way we access and consume knowledge. With just a few clicks, individuals can explore a vast collection of resources across different disciplines, all free of charge. This accessibility empowers individuals to become lifelong learners, contributing to personal growth, professional development, and the advancement of society as a whole. So why not unlock a world of knowledge today? Start exploring the vast sea of free PDF books and manuals waiting to be discovered right at your fingertips.

FAQs About 4efte Manual Books

1. Where can I buy 4efte Manual books? Bookstores: Physical bookstores like Barnes & Noble, Waterstones, and independent local stores. Online Retailers: Amazon, Book Depository, and various online bookstores offer a wide range of books in physical and digital formats.
2. What are the different book formats available? Hardcover: Sturdy and durable, usually more expensive. Paperback: Cheaper, lighter, and more portable than hardcovers. E-books: Digital books available for e-readers like Kindle or software like Apple Books, Kindle, and Google Play Books.
3. How do I choose a 4efte Manual book to read? Genres: Consider the genre you enjoy (fiction, non-fiction, mystery, sci-fi, etc.). Recommendations: Ask friends, join book clubs, or explore online reviews and recommendations. Author: If you like a particular author, you might enjoy more of their work.
4. How do I take care of 4efte Manual books? Storage: Keep them away from direct sunlight and in a dry environment. Handling: Avoid folding pages, use bookmarks, and handle them with clean hands. Cleaning: Gently dust the covers and pages occasionally.
5. Can I borrow books without buying them? Public Libraries: Local libraries offer a wide range of books for borrowing. Book Swaps: Community book exchanges or online platforms where people exchange books.
6. How can I track my reading progress or manage my book collection? Book Tracking Apps: Goodreads, LibraryThing, and Book Catalogue are popular apps for tracking your reading progress and managing book collections. Spreadsheets: You can create your own spreadsheet to track books read, ratings, and other details.
7. What are 4efte Manual audiobooks, and where can I find them? Audiobooks: Audio recordings of books, perfect for listening while commuting or multitasking. Platforms: Audible, LibriVox, and Google Play Books offer a wide selection of audiobooks.
8. How do I support authors or the book industry? Buy Books: Purchase books from authors or independent bookstores.

Reviews: Leave reviews on platforms like Goodreads or Amazon. Promotion: Share your favorite books on social media or recommend them to friends.

9. Are there book clubs or reading communities I can join? Local Clubs: Check for local book clubs in libraries or community centers. Online Communities: Platforms like Goodreads have virtual book clubs and discussion groups.
10. Can I read 4efte Manual books for free? Public Domain Books: Many classic books are available for free as they're in the public domain. Free E-books: Some websites offer free e-books legally, like Project Gutenberg or Open Library.

Find 4efte Manual :

clockwork angel the infernal devices themedore

class xii sc chemistry practical schedule

collections abc abc brevet

~~emc rope rescue field~~

chlorinated solvents a forensic evaluation

clinical medicine oxford assess and progress

codex 632 pdf

[clinical case studies in physiotherapy a for students and graduates 1e physiotherapy pocketbooks](#)

[clean architecture robert c martin 9780134494166](#)

[colectia el si ea](#)

cism review questions answers explanations manual 2015 supplement

[circuit theory and network analysis](#)

circulatory system gizmo assessment question answers

~~classical mechanics john r taylor solutions manual~~

clinical neuroanatomy made ridiculously simple 3rd edition

4efte Manual :

maths cycle 3 ed 2019 guide pédagogique - Apr 10 2023

web contactez nous rechercher connexion inscription

accueil pop hatier - Feb 08 2023

web hatier entraînement te donne accès à plus de 1 000 ressources en français en maths et en anglais des exercices des quiz

et des podcasts pour réviser à ton rythme

parcours français cm1 éd 2010 manuel de l élève editions - Sep 22 2021

guide d aide à l analyse et au choix d un manuel de grammaire - Mar 29 2022

hatier parcours cm2 copy - Dec 26 2021

capmaths cm2 hatier clic fr - Aug 02 2022

web hatier parcours cm2 les fables à l école du 21ème siècle jun 26 2022 la 4e de couv indique cet ouvrage vise à déterminer comment et pourquoi le genre des fables est

cm2 les enjeux de l apprentissage de l espace et de la géométrie - Apr 29 2022

web mar 24 2010 parcours cm1 nouvelle édition 2010 conforme aux programmes 2008 en tenant compte des suggestions des utilisateurs enseigner la grammaire le vocabulaire

manuels scolaires editions hatier - Mar 09 2023

web c quel itinéraire suivre pour aller de la gare de lyon à la gare d austerlitz située de l autre côté de la seine d utilise les fiches 127 et 128 et le plan du métro parisien en dernière

hatier parcours cm2 ftp bonide com - Feb 25 2022

hatier entraînement - Jul 01 2022

web hatier parcours cm2 hatier parcours cm2 au cm2 hatier entraînement stepfan mathématiques à l école primaire numération maths ma maitresse de cm1 cm2 l

parcours français cm2 manuel 2010 hatier buroland - Sep 03 2022

web hatier parcours cm2 lia erc gov ph keywords a p e r hatier entraînement théâtre le cartable de séverine la compréhension des textes narratifs récits et romans recherche

parcours editions hatier - Jul 13 2023

web liens hatier clic didier clic dans les manuels exercices interactifs élèves capsules histoire géo sites ressources collection applis faq numérique formulaire

parcours cm2 cahier nouvelle édition fnac - Jan 07 2023

web achetez sur moncartable ma parcours français cm2 manuel 2010 hatier connexion contactez nous appelez nous au 0631757575 rechercher panier 0 produit produits

français cm2 Éd 2021 livre élève éditions hatier - Dec 06 2022

web 1 hatier 2021 cap maths cm2 ce document explicite les principales orientations de cap maths dans le domaine espace et géométrie pour aider à la compréhension et la

parcours français cm2 éd 2010 manuel de l élève - Aug 14 2023

web ce1 nouveau parcours français ce1 éd 2011 manuel de l élève éditions hatier ce2 nouveau parcours français ce2 éd 2011 manuel de l élève éditions hatier cm1

éditions hatier livres scolaires livres numériques - Nov 05 2022

web guide d aide à l analyse et au choix d un manuel de grammaire pour le cycle 3 nom du manuel parcours cm1 auteurs richard assuied danielle buselli et anne marie

hatier parcours cm2 - Nov 24 2021

pop parcours personnalisés éditions hatier - Jun 12 2023

web résumé ce cahier d activités parcours cm2 complète le manuel de l élève et constitue un outil de travail individuel efficace l ensemble des activités proposées permet la maîtrise

classes themes hatier entraînement - Oct 04 2022

web mes jeux de vacances du cm1 vers le cm2 2022 thérèse raquin hatier parcours cm2 downloaded from ftp bonide com by guest ty lynn histoire géographie emc crpe

hatier parcours cm2 lia erc gov - Jan 27 2022

pop parcours personnalisés cycle 3 hatier - May 11 2023

web hatier entraînement te donne accès à plus de 1 000 ressources en français en maths et en anglais des exercices des quiz et des podcasts pour réviser à ton rythme cm2

parcours français cm2 manuel 2010 hatier - May 31 2022

web hatier entraînement recherche contenus complémentaires éditions hatier accueil frimaudeau btoc stepfan mathématiques à l école primaire numération maths ma

hatier parcours cm2 - Oct 24 2021

welcome office of scholarships financial aid - Apr 13 2022

web how do i find financial aid hint we ll make it easy select from the options below and learn more about the financial aid application process funding options and more incoming first year i m a first time college student learn more incoming

transfer in applying from another college or university learn more graduate

finance 360 360 u of a course hero - Apr 25 2023

web access study documents get answers to your study questions and connect with real tutors for finance 360 360 at university of arizona upload to study expert help

advanced financial management and analysis fin 689 - Mar 24 2023

web studying fin 689 advanced financial management and analysis at the university of arizona global campus on studocu you will find 41 assignments essays summaries

fin 370 uagc financial applications studocu - Jan 22 2023

web studying fin 370 financial applications at the university of arizona global campus on studocu you will find 39 mandatory assignments and much more for fin 370 uagc

your ultimate guide to the fafsa admissions university of arizona - Feb 11 2022

web applying for financial aid to fund your education tuition housing school supplies and textbooks there s a lot that goes into paying for college fortunately you have many options when it comes to making your university of arizona education more affordable

fy 2022 annual comprehensive financial report university of arizona - Aug 29 2023

web nov 9 2022 the university has issued its fiscal year 2022 annual comprehensive financial report acfr university analytics and institutional research uair updated the interactive fact book to reflect results from the fiscal year 2022 acfr

home financial services university of arizona - Jun 15 2022

web join the university business offices email list to receive information about the uaccess financials system applicable policies and procedures and important notices from financial services to university of arizona business offices note employees with business and administrative user access role 54 are automatically subscribed to this list

fin 510a financial management u of a course hero - Jun 27 2023

web newly uploaded documents access study documents get answers to your study questions and connect with real tutors for fin 510a financial management at university of arizona

universityofarizonaanswerkeyfinancialactivity - Jul 16 2022

web financial accounting catalog of federal domestic assistance principles of accounting volume 1 financial accounting hearings higher education response to exponential societal shifts bus regulatory reform act of 1982 encyclopedia of disaster relief the earth observer campus activities financial accounting privacy act issuances compilation

fy 2021 annual comprehensive financial report university of arizona - Jul 28 2023

web nov 2 2021 the university of arizona has now issued its fiscal year 2021 annual comprehensive financial report acfr

university analytics and institutional research uair updated the interactive fact book to reflect results from the fiscal year 2021 acfr the updated page features revenues expenditures and the change in net position for

university of arizona answer key financial activity book - Mar 12 2022

web feb 27 2023 university of arizona answer key financial activity right here we have countless ebook university of arizona answer key financial activity and collections to check out we additionally allow variant types and also type of the books to browse the enjoyable book fiction history novel scientific research as without difficulty as

university of arizona answer key financial activity - Jan 10 2022

web money for under as with ease as evaluation university of arizona answer key financial activity what you once to read pfin 3 lawrence gitman 2013 02 25 created through an extensive student tested faculty approved review process with student and faculty input pfin3 is an engaging and accessible solution designed to

university of arizona answer key financial activity pdf - Aug 17 2022

web arizona state university institute of public administration 1966 hearings reports and prints of the senate committee on appropriations united states congress senate committee on appropriations 1964 arizona review 1979 planning curriculum in personal financial literacy beth e ratway 2009 the incubation workbook

fin 360 quantitative financial management u of a course hero - Oct 19 2022

web access study documents get answers to your study questions and connect with real tutors for fin 360 quantitative financial management at university of arizona

financial aid the university of arizona online - May 14 2022

web the fafsa is available oct 1 for academic years beginning in fall submit your fafsa at least 60 days before your planned start term to ensure financial aid is offered in a timely manner be sure to include the university of arizona s school code 001083 when you submit your fafsa to avoid delays in the processing of your aid 2

annual comprehensive financial reports financial services - Dec 21 2022

web jun 30 2014 the university of arizona annual comprehensive financial report is available below financial report for fiscal year ended june 30 2022 previous years

finance fin 520 fin 520 university of arizona course hero - Feb 23 2023

web access study documents get answers to your study questions and connect with real tutors for finance fin 520 fin 520 at university of arizona

fin 311 introduction to finance u of a course hero - May 26 2023

web fin 311 final exam study guide answer key final exam study guide calculations answer key present and future value problems 1 you have won 750 000 arizona lottery offers you 525 000 right now or 75 000 a year for ten years assuming you

could invest the funds at 7 which is a better option

family economics financial education university of arizona - Sep 18 2022

web activity based ready to teach customized services to address localschool free of charge up to date linked to standards and state needs national and state family focus educator support training model 500 trained each full time staff to answer questions summer newsletters

the university of arizona - Nov 20 2022

web title university of arizona june 30 2019 highlights annual financial report author az auditor general created date 11 13 2019 5 08 24 pm

plastics additives handbook by hans zweifel open library - Aug 11 2022

jul 29 2020 imported from scriblio marc record plastics additives handbook by hans zweifel 2001 hanser gardner publications edition in english 5th ed

plastics additives handbook 6e 6th edition - Jun 09 2022

apr 22 2017 the additive is used in common plastic household items such as tv computer housing polyurethane foam and fabric 40 as well the global market for fr chemicals was

plastics additives handbook 5th edition amazon com - Jan 04 2022

plastics additives third edition edited by r gachter and h müller hanser verlag munich 1990 pp v 970 price dm 148 00 isbn 3446 15680 1 billingham 1991 polymer

plastics additives handbook google books - Feb 17 2023

plastics additives handbook google books hans zweifel ralph d maier michael schiller hanser 2009 plastics 1222 pages plastics without additives are not viable additives are

additives for plastics handbook sciencedirect - Aug 23 2023

book description both technically and economically additives form a large and increasingly significant part of the polymer industry both plastics and elastomers since the first edition of

plastics additives handbook stabilizers processing aids - Nov 14 2022

plastics additives handbook stabilizers processing aids plasticizers fillers reinforcements colorants for thermoplastics r gachter h muller oxford university press

plastics additives third edition edited by r gachter and h - Dec 03 2021

dec 1 2000 read reviews from the world s largest community for readers plastics without additives are not viable additives are essential to make plastics processabl

plastics additives handbook worldcat org - Sep 12 2022

plastics additives handbook worldcat org authors hans zweifel st e amos print book english 2001 edition 5th ed view all formats and editions publisher hanser gardner

additives for plastics handbook 2nd edition elsevier - Jan 16 2023

nov 22 2001 this new edition follows the successful formula of its predecessor it provides a comprehensive view of all types of additives concentrating mainly on their technical aspects

additives for plastics handbook google books - Mar 18 2023

nov 22 2001 additives for plastics handbook j murphy elsevier nov 22 2001 technology engineering 484 pages both technically and economically additives form a

plastics additives handbook google books - Dec 15 2022

plastics additives handbook hans zweifel stephen e amos hanser gardner publications 2001 plastics 1148 pages plastics without additives are not viable additives are essential to

plastics additives handbook 6e hanser publications - Sep 24 2023

isbn 9781569904305 hardcover 1248 pages 329 99 us add to cart contents antioxidants light stabilizers pvc stabilizers acid scavengers lubricants processing

pdf plastics additives handbook academia edu - Jun 21 2023

pdf plastics additives handbook stabilizers processing aids fillers reinforcements colorants for thermoplasticsr gächter and h müller eds carl hanser verlag münchen

book review plastics additives handbook 5th edition by h - Jul 10 2022

jan 1 2008 plastics additives handbook 5th ed by h zweifel munich hanser publications 2001 isbn 1 56990 144 9 no full text available citations 2

plastics additives handbook 6e zweifel hans 9781569904305 - Mar 06 2022

michael schiller yaynevi hanser verlag yayın tarihi 06 2009 isbn 9783446408012 ciltli İngilizce 1248 sayfa tür makine temin süresi 45 65 iş günü Üye giriş yapın

plastics additives handbook by hans zweifel goodreads - Nov 02 2021

plastics handbook sciencedirect - Apr 07 2022

6 ratings by goodreads hardcover isbn 10 1569904308 isbn 13 9781569904305 publisher hanser publications 2009 view all copies of this isbn edition synopsis about this edition

pandora plastics additives handbook michael schiller kitap - Feb 05 2022

plastics additives handbook 5th edition paperback see all formats and editions paperback 39 99 2 used from 39 99

plastic additive standards guide - Jul 22 2023

handbook for the chemical analysis of plastic and polymer additives 2nd ed the second edition of this handbook provides the necessary tools for chemists to obtain a more complete

describing uses of additives in plastic material for articles and - Oct 13 2022

describing uses of additives in plastic material for articles and estimating related exposure practical guide for industry reference echa 20 h 07 en isbn 978 92 9481 398 5 cat

polymer additives handbook of polymer wiley - Apr 19 2023

feb 22 2013 summary additives are essential components in polymer formulations to maintain and to extend polymer properties many additive classes are seen today as

additives and chemicals in plastics springerlink - May 08 2022

plastics handbook is a comprehensive and authoritative reference for plastics engineers scientists and students it covers the properties processing testing and applications of

plastics additives handbook ralph d maier michael schiller - May 20 2023

plastics additives handbook ralph d maier michael schiller hanser publications 2009 plastics 1222 pages plastics without additives are not viable additives are essential to make