

# Piping

## Isometric

## Tutorial

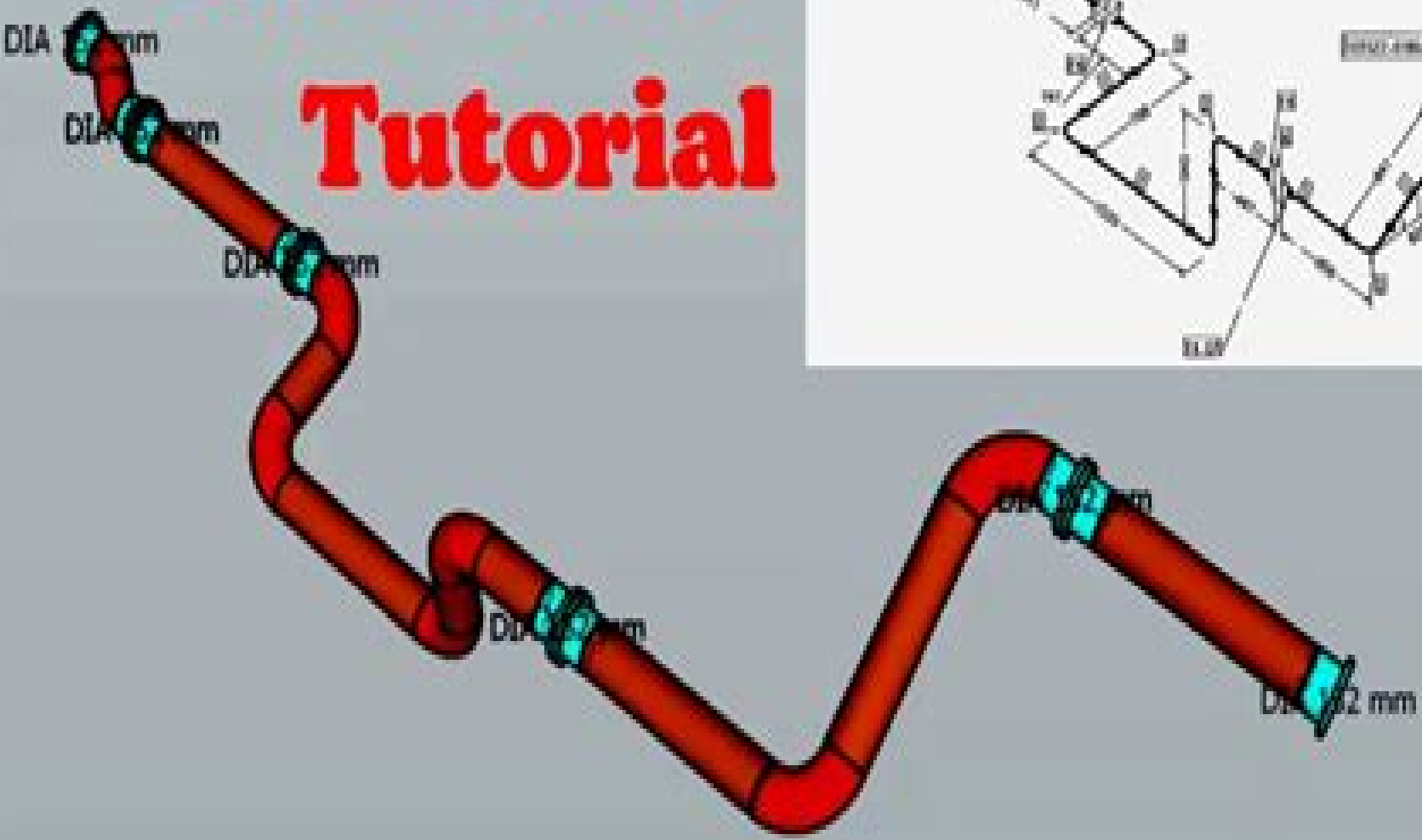
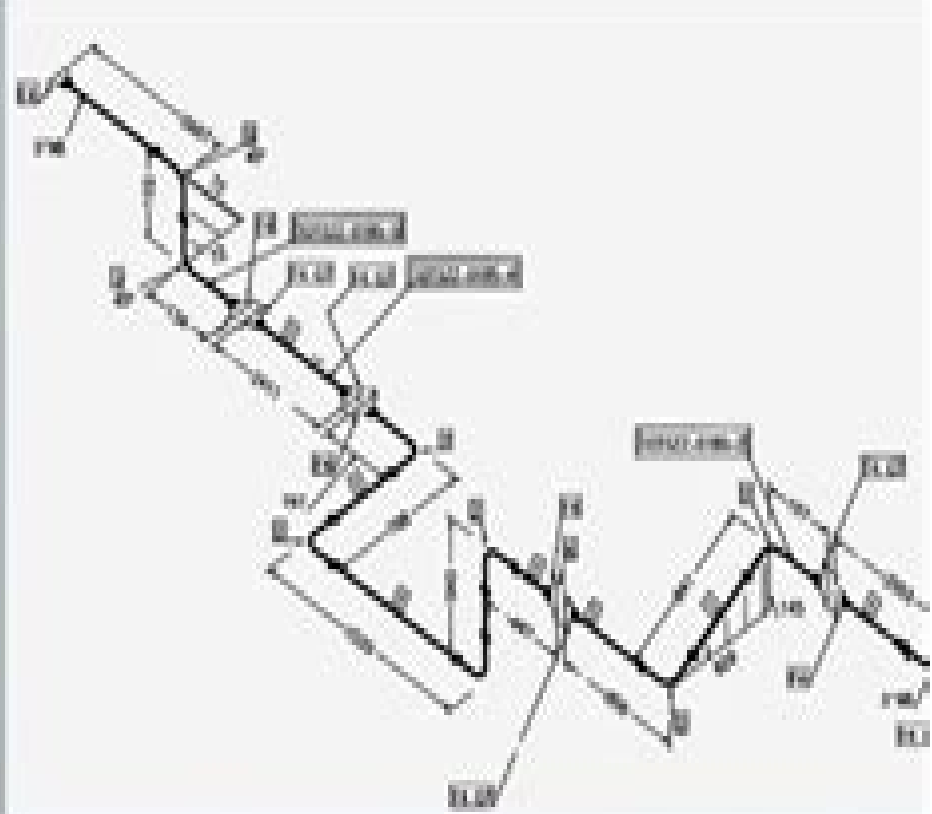

# Tutorial Manual For Piping

**Shawna D. Lockhart, Marc Finseth**



## **Tutorial Manual For Piping:**

**Stats Cosmos Piping Applications Google Cloud Dataproc Deployment Guide** Mr. Luthando Mayekiso,2018-05-25  
The guide is an introductory guide to deploying piping applications on the Google Cloud Dataproc Application Programming Interface API The piping applications considered are those used for category counting property summing and property averaging in a managed cluster environment in the cloud [System Integration Guide, Query Language Reference Manual and Tutorial](#) ,1994 [A Tutorial Guide to AutoCAD 2006](#) Shawna D. Lockhart,2006 A Tutorial Guide to AutoCAD 2006 provides a step by step introduction to AutoCAD with commands taught in context In 15 clear and comprehensive sessions author Shawna Lockhart guides readers through all the important commands and techniques in AutoCAD 2006 from 2D to solid modeling In each lesson the author provides step by step instructions with frequent illustrations showing exactly what appears on the AutoCAD screen Later individual steps are no longer provided and readers are asked to apply what they ve learned by completing sequences on their own Carefully developed pedagogy reinforces this cumulative learning approach and supports readers in becoming skilled AutoCAD users Introduction to AutoCAD Basic Construction Techniques Basic Editing and Plotting Techniques Geometric Constructions Template Drawings and More Plotting 2D Orthographic Drawings Dimensioning Advanced Dimensioning Section and Auxiliary Views Blocks Design Center and Tool Palettes Introduction to Solid Modeling Changing and Plotting Solid Models Creating Assembly Drawings from Solid Models Solid Modeling for Section and Auxiliary Views Rendering **Geotechnics for Developing Africa** G.E. Blight,A.B. Fourie,G.R. Wardle,2021-06-30 The proceedings represent a valuable reference on geotechnical problems peculiar to Africa and for engineering solutions to local problems Topics covered are Foundation engineering and lateral support Methods of design and analysis Monitoring laboratory and field testing Municipal industrial and mining waste and environmental geotechnics Soil improvement Transportation geotechnics Case studies The proceedings are also an invaluable source of data on the properties of African soils the properties of residual and tropical soils as well as climate related problems [Piping Engineering Today](#) Eric Van Stijgeren,1984 **NASA Lewis Propulsion Systems Laboratory Customer Guide Manual** ,1994 [Pipeline Engineering ebook Collection](#) E.W. McAllister,W. Kent Muhlbauer,Marshall Parker,Keith Escoe,Roy A. Parisher,Mehdi Farshad,2008-09-05 Pipeline Engineering ebook Collection contains 6 of our best selling titles providing the ultimate reference for every pipeline professional s library Get access to over 3000 pages of reference material at a fraction of the price of the hard copy books This CD contains the complete ebooks of the following 6 titles McAllister Pipeline Rules of Thumb 6th Edition 9780750678520 Muhlbauer Pipeline Risk Management Manual 3rd Edition 9780750675796 Parker Pipeline Corrosion Cathodic Protection 3rd Edition 9780872011496 Escoe Piping Pipeline Assessment Guide V1 9780750678803 Parisher Pipe Drafting Design 2nd Edition 9780750674393 Farshad Plastic Pipe Systems Failure Investigation and Diagnosis 9781856174961 Six fully searchable titles on one CD providing instant access to the ULTIMATE

library of engineering materials for pipeline professionals 3000 pages of practical and theoretical pipeline information in one portable package Incredible value at a fraction of the cost of the print books

**A Tutorial Guide to AutoCAD Release 14** Shawna D. Lockhart,1998 A Tutorial Guide to AutoCAD Release 14 is the ideal tool for learning the latest release of engineering s most popular design tool These tutorials take you from basics such as parts of the screen and simple command entry all the way through customizing your AutoCAD toolbars and creating your own commands In 15 clear and comprehensive sessions author Shawna Lockhart guides readers through all the important commands and techniques in AutoCAD 14 As you progress through the step by step tutorials you apply what you have learned by completing familiar sequences on your own Frequent illustrations clearly depict what you see on your screen to help you in following the steps outlined

**A Tutorial Guide to AutoCAD 2000** Shawna D. Lockhart,Marc Finseth,2001 For courses in AutoCAD and Computer Aided Drawing A Tutorial Guide to AutoCAD 2000 provides a step by step introduction to AutoCAD with commands taught in context Lockhart begins this book providing step by step instructions using commands and techniques Later individual steps are no longer provided and readers are asked to apply what they have learned by completing sequences on their own Carefully developed pedagogy reinforces the cumulative learning approach and supports readers in becoming skilled AutoCAD users

*CompTIA Linux+ Study Guide* Roderick W. Smith,2013-01-14 Includes real world scenarios hands on exercises and access to exam prep software featuring Linux Mac and Windows Compatible test engines hundreds of sample questions electronic flashcards Cover

**LPIC-1: Linux Professional Institute Certification Study Guide** Roderick W. Smith,2013-01-14 Updated for the latest LPIC 1 Exams 101 and 102 The LPIC 1 certification measures your understanding of the Linux Kernel As the Linux server market continues to grow so does the demand for certified Linux administrators Prepare for the latest versions of the LPIC 1 exams 101 and 102 with the new edition of this detailed Study Guide This practical book covers key Linux administration topics and all exam objectives and includes real world examples and review questions to help you practice your skills In addition you ll gain access to a full set of online study tools including bonus practice exams electronic flashcards and more Prepares candidates to take the Linux Professional Institute exams 101 and 102 and achieve their LPIC 1 certification Covers all exam objectives and features expanded coverage on key topics in the exam Includes real world scenarios and challenging review questions Gives you online access to bonus practice exams electronic flashcards and a searchable glossary Topics include system architecture installation GNU and Unix commands Linux filesystems essential system services networking fundamentals security and more Approach the LPIC 1 certification exams with confidence with LPIC 1 Linux Professional Institute Certification Study Guide Third Edition

**Heating, Piping, and Air Conditioning** ,1963 Issues for Jan 1935 contain a directory of heating piping and air conditioning equipment

*Professional Guide's Manual* George Leonard Herter,Jacques Pierre Herter,1960

**Finite element theory and its application with open source codes** Anthony Pickett,2020-11-10 This book combines essential finite element FE theory

with a set of fourteen tutorials using relatively easy to use open source CAD FE and other numerical analysis codes so a student can undertake practical analysis and self study The theory covers fundamentals of the finite element method Formulation of element stiffness for one dimensional bar and beam two dimensional and three dimensional continuum elements plate and shell elements are derived based on energy and variational methods Linear nonlinear and transient dynamic solution methods are covered for both mechanical and field analysis problems with a focus on heat transfer Other important theoretical topics covered include element integration element assembly loads boundary conditions contact and a chapter devoted to material laws on elasticity hyperelasticity and plasticity A brief introduction to Computational Fluid Dynamics CFD is also included The second half of this book presents a chapter on using tutorials containing information on code installation on Windows and getting started and general hints on meshing modelling and analysis This is then followed by tutorials and exercises that cover linear nonlinear and dynamic mechanical analysis steady state and transient heat analysis field analysis fatigue buckling and frequency analysis a hydraulic pipe network analysis and lastly two tutorials on CFD simulation In each case theory is linked with application and exercises are included for further self study For these tutorials open source codes FreeCAD CalculiX FreeMAT and OpenFOAM are used CalculiX is a comprehensive FE package covering linear nonlinear and transient analysis One particular benefit is that its format and structure is based on Abaqus so knowledge gained is relevant to a leading commercial code FreeCAD is primarily a powerful CAD modelling code that includes good finite element meshing and modelling capabilities and is fully integrated with CalculiX FreeMAT is used in three tutorials for numerical analysis demonstrating algorithms for explicit finite element and CFD analysis And OpenFOAM is used for other CFD flow simulations The primary aim of this book is to provide a unified text covering theory and practice so a student can learn and experiment with these versatile and powerful analysis methods It should be of value to both finite element courses and for student self study

*Plumber's and Pipe Fitter's Calculations Manual* Roger Dodge Woodson,1999 Get results almost instantly without putting pencil to paper or fiddling with a calculator Packed with charts and tables that let you simply look up the answers you need this handy new tool for plumbers and pipe fitters gives you a ready source of commonly used calculations formulas and best of all solutions

*Process Piping* CHARLES BECHT IV.,2021 This book is based on the 2020 Edition of ASME B31 3 Process Piping Code Because changes some very significant are made to the Code every edition the reader should refer to the Code for any specific requirements This book should be considered as providing background information and not specific current Code rules The equations in this book are numbered sequentially in each chapter When equations from ASME B31 3 are reproduced herein the latter equation numbers are given as well

**A Tutorial Guide to AutoCAD Release 12** Shawna D. Lockhart,1994 This book uses a tried and true tutorial approach to teach readers how to apply AutoCAD to solving engineering drawing problems This format teaches AutoCAD commands in context making it easier for readers to apply what they have learned The book contains solid Getting Started material good

coverage of views and superior coverage of dimensioning The Street Railway Journal ,1914 **Piping Materials Guide**  
Peter Smith,2005-01-20 The only book of its kind on the market this book is the companion to our Valve Selection Handbook  
by the same author Together these two books form the most comprehensive work on piping and valves ever written for the  
process industries This book covers the entire piping process including the selection of piping materials according to the job  
the application of the materials and fitting trouble shooting techniques for corrosion control inspections for OSHA  
regulations and even the warehousing distributing and ordering of materials There are books on materials fitting OSHA  
regulations and so on but this is the only one stop shopping source for the piping engineer on piping materials Provides a one  
stop shopping source for the piping engineer on piping materials Covers the entire piping process Designed as an easy to  
access guide **Chilton's Import Auto Service Manual** ,2000 Contains general information for technicians on the  
specifications MIL resetting and DTC retrieval accessory drive belts timing belts brakes oxygen sensors electric cooling fans  
and heater cores of twenty one types of import cars

Right here, we have countless ebook **Tutorial Manual For Piping** and collections to check out. We additionally come up with the money for variant types and also type of the books to browse. The good enough book, fiction, history, novel, scientific research, as without difficulty as various other sorts of books are readily affable here.

As this Tutorial Manual For Piping, it ends stirring living thing one of the favored ebook Tutorial Manual For Piping collections that we have. This is why you remain in the best website to look the incredible ebook to have.

<https://py.bijouxmedusa.com/results/book-search/index.jsp/Creators%2010%201673%20Career%20Growth%20Best%20Practices%20For%20Creators%2010%20722%20Career.pdf>

## **Table of Contents Tutorial Manual For Piping**

1. Understanding the eBook Tutorial Manual For Piping
  - The Rise of Digital Reading Tutorial Manual For Piping
  - Advantages of eBooks Over Traditional Books
2. Identifying Tutorial Manual For Piping
  - Exploring Different Genres
  - Considering Fiction vs. Non-Fiction
  - Determining Your Reading Goals
3. Choosing the Right eBook Platform
  - Popular eBook Platforms
  - Features to Look for in an Tutorial Manual For Piping
  - User-Friendly Interface
4. Exploring eBook Recommendations from Tutorial Manual For Piping
  - Personalized Recommendations
  - Tutorial Manual For Piping User Reviews and Ratings
  - Tutorial Manual For Piping and Bestseller Lists
5. Accessing Tutorial Manual For Piping Free and Paid eBooks

- Tutorial Manual For Piping Public Domain eBooks
  - Tutorial Manual For Piping eBook Subscription Services
  - Tutorial Manual For Piping Budget-Friendly Options
6. Navigating Tutorial Manual For Piping eBook Formats
- ePub, PDF, MOBI, and More
  - Tutorial Manual For Piping Compatibility with Devices
  - Tutorial Manual For Piping Enhanced eBook Features
7. Enhancing Your Reading Experience
- Adjustable Fonts and Text Sizes of Tutorial Manual For Piping
  - Highlighting and Note-Taking Tutorial Manual For Piping
  - Interactive Elements Tutorial Manual For Piping
8. Staying Engaged with Tutorial Manual For Piping
- Joining Online Reading Communities
  - Participating in Virtual Book Clubs
  - Following Authors and Publishers Tutorial Manual For Piping
9. Balancing eBooks and Physical Books Tutorial Manual For Piping
- Benefits of a Digital Library
  - Creating a Diverse Reading Collection Tutorial Manual For Piping
10. Overcoming Reading Challenges
- Dealing with Digital Eye Strain
  - Minimizing Distractions
  - Managing Screen Time
11. Cultivating a Reading Routine Tutorial Manual For Piping
- Setting Reading Goals Tutorial Manual For Piping
  - Carving Out Dedicated Reading Time
12. Sourcing Reliable Information of Tutorial Manual For Piping
- Fact-Checking eBook Content of Tutorial Manual For Piping
  - Distinguishing Credible Sources
13. Promoting Lifelong Learning
- Utilizing eBooks for Skill Development

- Exploring Educational eBooks
14. Embracing eBook Trends
- Integration of Multimedia Elements
  - Interactive and Gamified eBooks

### **Tutorial Manual For Piping Introduction**

In today's digital age, the availability of Tutorial Manual For Piping books and manuals for download has revolutionized the way we access information. Gone are the days of physically flipping through pages and carrying heavy textbooks or manuals. With just a few clicks, we can now access a wealth of knowledge from the comfort of our own homes or on the go. This article will explore the advantages of Tutorial Manual For Piping books and manuals for download, along with some popular platforms that offer these resources. One of the significant advantages of Tutorial Manual For Piping books and manuals for download is the cost-saving aspect. Traditional books and manuals can be costly, especially if you need to purchase several of them for educational or professional purposes. By accessing Tutorial Manual For Piping versions, you eliminate the need to spend money on physical copies. This not only saves you money but also reduces the environmental impact associated with book production and transportation. Furthermore, Tutorial Manual For Piping books and manuals for download are incredibly convenient. With just a computer or smartphone and an internet connection, you can access a vast library of resources on any subject imaginable. Whether you're a student looking for textbooks, a professional seeking industry-specific manuals, or someone interested in self-improvement, these digital resources provide an efficient and accessible means of acquiring knowledge. Moreover, PDF books and manuals offer a range of benefits compared to other digital formats. PDF files are designed to retain their formatting regardless of the device used to open them. This ensures that the content appears exactly as intended by the author, with no loss of formatting or missing graphics. Additionally, PDF files can be easily annotated, bookmarked, and searched for specific terms, making them highly practical for studying or referencing. When it comes to accessing Tutorial Manual For Piping books and manuals, several platforms offer an extensive collection of resources. One such platform is Project Gutenberg, a nonprofit organization that provides over 60,000 free eBooks. These books are primarily in the public domain, meaning they can be freely distributed and downloaded. Project Gutenberg offers a wide range of classic literature, making it an excellent resource for literature enthusiasts. Another popular platform for Tutorial Manual For Piping books and manuals is Open Library. Open Library is an initiative of the Internet Archive, a nonprofit organization dedicated to digitizing cultural artifacts and making them accessible to the public. Open Library hosts millions of books, including both public domain works and contemporary titles. It also allows users to borrow digital copies of certain books for a limited period, similar to a library lending system. Additionally, many universities and educational

institutions have their own digital libraries that provide free access to PDF books and manuals. These libraries often offer academic texts, research papers, and technical manuals, making them invaluable resources for students and researchers. Some notable examples include MIT OpenCourseWare, which offers free access to course materials from the Massachusetts Institute of Technology, and the Digital Public Library of America, which provides a vast collection of digitized books and historical documents. In conclusion, Tutorial Manual For Piping books and manuals for download have transformed the way we access information. They provide a cost-effective and convenient means of acquiring knowledge, offering the ability to access a vast library of resources at our fingertips. With platforms like Project Gutenberg, Open Library, and various digital libraries offered by educational institutions, we have access to an ever-expanding collection of books and manuals. Whether for educational, professional, or personal purposes, these digital resources serve as valuable tools for continuous learning and self-improvement. So why not take advantage of the vast world of Tutorial Manual For Piping books and manuals for download and embark on your journey of knowledge?

### **FAQs About Tutorial Manual For Piping Books**

1. Where can I buy Tutorial Manual For Piping books? Bookstores: Physical bookstores like Barnes & Noble, Waterstones, and independent local stores. Online Retailers: Amazon, Book Depository, and various online bookstores offer a wide range of books in physical and digital formats.
2. What are the different book formats available? Hardcover: Sturdy and durable, usually more expensive. Paperback: Cheaper, lighter, and more portable than hardcovers. E-books: Digital books available for e-readers like Kindle or software like Apple Books, Kindle, and Google Play Books.
3. How do I choose a Tutorial Manual For Piping book to read? Genres: Consider the genre you enjoy (fiction, non-fiction, mystery, sci-fi, etc.). Recommendations: Ask friends, join book clubs, or explore online reviews and recommendations. Author: If you like a particular author, you might enjoy more of their work.
4. How do I take care of Tutorial Manual For Piping books? Storage: Keep them away from direct sunlight and in a dry environment. Handling: Avoid folding pages, use bookmarks, and handle them with clean hands. Cleaning: Gently dust the covers and pages occasionally.
5. Can I borrow books without buying them? Public Libraries: Local libraries offer a wide range of books for borrowing. Book Swaps: Community book exchanges or online platforms where people exchange books.
6. How can I track my reading progress or manage my book collection? Book Tracking Apps: Goodreads, LibraryThing,

and Book Catalogue are popular apps for tracking your reading progress and managing book collections. Spreadsheets: You can create your own spreadsheet to track books read, ratings, and other details.

7. What are Tutorial Manual For Piping audiobooks, and where can I find them? Audiobooks: Audio recordings of books, perfect for listening while commuting or multitasking. Platforms: Audible, LibriVox, and Google Play Books offer a wide selection of audiobooks.
8. How do I support authors or the book industry? Buy Books: Purchase books from authors or independent bookstores. Reviews: Leave reviews on platforms like Goodreads or Amazon. Promotion: Share your favorite books on social media or recommend them to friends.
9. Are there book clubs or reading communities I can join? Local Clubs: Check for local book clubs in libraries or community centers. Online Communities: Platforms like Goodreads have virtual book clubs and discussion groups.
10. Can I read Tutorial Manual For Piping books for free? Public Domain Books: Many classic books are available for free as they're in the public domain. Free E-books: Some websites offer free e-books legally, like Project Gutenberg or Open Library.

### **Find Tutorial Manual For Piping :**

**creators 10-1673 career growth best practices for creators 10-722 career**  
[10-1550 real estate investing comparison for entrepreneurs 10-334 real](#)  
**tutorial for startups 10-1890 NFT marketplace apps for entrepreneurs**  
**interview tips strategies for entrepreneurs 10-1527 interview tips**  
[business ideas trends USA 10-1839 small business ideas trends for](#)  
[machine learning basics tutorial for entrepreneurs 10-898 machine](#)  
[startups 10-1940 travel tips checklist for startups 10-202 travel tips](#)  
**privacy software for entrepreneurs 10-791 online privacy software for**  
[small business 10-1106 resume writing blueprint United States 10-2445](#)  
**ideas guide America 10-670 passive income ideas guide United States**  
[score improvement tutorial America 10-1311 credit score improvement](#)  
**10-1503 real estate investing for beginners United States 10-2245 real**  
[entrepreneurs 10-971 print on demand tools for small business 10-578](#)  
**strategy guide USA 10-2596 SEO strategy guide for startups 10-2453 SEO**

## electric vehicles review for creators 10-127 electric vehicles roadmap

### Tutorial Manual For Piping :

*notary public department of state - Apr 12 2023*

web jan 25 2023 requirements submit a completed application and the required fee to the department of state pass the new york state notary public examination nys attorneys and court clerks of the unified court system are exempt from the examination be a resident of new york state or have an office or place of business in new york state next

**free nys notary exam practice 2023 prep guide - Oct 18 2023**

web jan 28 2020 the nys notary exam is a written test consisting of 40 multiple choice questions you will be allowed 1 hour to complete the exam you need to score at least 70 or 28 out of 40 to pass the exam the questions are based entirely on the new york state notary license law

*nys notary exam questions flashcards quizlet - May 01 2022*

web notary practice test 1 40 terms braver1093 preview nys notary practice exam 2021 81 terms liz hessler preview new york notary 2023 practice exam 1 40 terms asamonkey preview new york state notary public license exam 163 terms jstudyw preview business law and ethics chapter 15 17 terms cedric square preview

**free nys notary exam practice 2023 prep guide new york state notary - Sep 05 2022**

web jan 28 2020 the nys notary exam has a written test consisting of 40 multiple choice questions you will be allowed 1 hourly for completely the exam you need to score at least 70 conversely 28 out of 40 to pass the exam the answer represent based on entirely in the new york state notary license law

*new york notary exam practice test flashcards quizlet - Dec 08 2022*

web new york notary exam practice test flashcards q chat get a hint if a notary refused to notarize an affidavit presented for ny notary mobile services what is the potential maximum jail sentence one month three months six months one year click the card to flip nathan 2023 terms in this set 40

**sample ny notary practice exam 2023 unbate - Feb 27 2022**

web a be at least 18 years old b no special education or common school level c be a resident and or a qualified non resident resident d all the above 4 if a notary moves to another state but still works in n y s he she a will pay an additional 15 out of state fee b no longer is qualified c must get ny driver s license

notary exams test dates for new york notarytrainer - Nov 26 2021

web new york notary public walk in examination schedule test sites and times are subject to change and exams may be canceled due to weather conditions or other emergencies if hazardous weather conditions exist in your area you may call 518

474 4429 to see if an exam has been canceled please do not call the test centers listed below  
[br free nys notary exam practice 2023 prep guide practice tests state - Aug 16 2023](#)

web the nys notary exam is a writing check consisting of 40 multiple choice questions you will be allowed 1 hours to completed the exam thee need to score at least 70 or 28 away about 40 until pass the check the inquiries are based entirely on the new york state notary zulassung law

**new york notary 2023 practice exam 2 flashcards quizlet** - Mar 31 2022

web as per case law click the card to flip 1 40 flashcards learn test match q chat asamonkey top creator on quizlet terms in this set 40 1 which of the following four choices relating to these two statements is most correct 1 do you solemnly swear that the contents of this affidavit subscribed by you is correct and true 2

**new york notary 2023 practice exam 1 flashcards quizlet** - Jun 14 2023

web study with quizlet and memorize flashcards containing terms like 1 which of the following statements is not correct a fee for notary public commission is 60 b the secretary of state commissions notaries public c the term of a notary public commission is 2 years d notary public examinations are scheduled throughout nys 2

[new york notary practice test 2 flashcards quizlet](#) - Jun 02 2022

web 1 20 flashcards learn test match q chat created by apicarro14 terms in this set 20 when performing a protest for non payment a new york notary may charge 10 for the transaction 2 per signature notarized 75 for the first protest and 10 for each additional up to a total of 5 protests per bill no charge is allowed for protests

[free practice exam answers notary public classes ny state](#) - Dec 28 2021

web notary public new york state live seminars classes home live notary classes locations rochester notary classes albany notary classes thank you for taking the practice exam here are the answers 1 d 2 c 3 d 4 d 5 d 6 b 7 b 8 d 9 b 10 b 11 a 12 d 13 d 14 d 15 a 16 c 17 c 18 b 19 d 20 a 21 d 22 b 23 b

**nys notary exam flashcards chegg com** - Jan 29 2022

web 1 year the notary certificate of a witness to the execution of a real estate conveyance is called a proof certificate which of the following is a requirement to become a notary public in new york be at least 18 years old no special education or common school level be a resident and or a qualified non resident resident

*become a notary public department of state dos ny gov* - Aug 04 2022

web requirements submit a completed application and the required fee to the department of state pass the new york state notary public examination nys attorneys and court clerks of the unified court system are exempt from the examination be a resident of new york state or have an office or place of business in new york state

[sample ny notary practice exam notary public classes ny state](#) - Sep 17 2023

web view on mobile sample ny notary practice exam for anyone taking the notary exam in new york state nys nyc or any county or city in the state of new york free to practice and learn

[new york notary exam sample questions](#) - Mar 11 2023

web nov 9 2022 here are some new york notary exam sample questions remember this all of the questions come from the new york state notary license law to get a copy of the licensing law visit new york s website and scroll down to the link laws rules and regulations you can then download the pdf file

*how to prepare for and pass the ny notary exam nna* - Jul 03 2022

web may 27 2015 run through 80 minute practice tests before exam day take mini quizzes to help you avoid the trickier legal questions learn how to properly id signers and prevent forgeries understand how to handle the new closing disclosures before the august 1 deadline fill out your comprehensive notary application flawlessly

[free nys notary exam practice 2023 prep guide new york state notary](#) - Oct 06 2022

web the new york state nys notary exam can a critical step in becoming a notary public in new york this exam remains conceptual to assess your understanding of the rules rules plus regulations governing notarial acts as outlined in

*free nys notary exam practice 2023 prep guide notary public* - Nov 07 2022

web jan 28 2020 test listfree practice of new york state nys certified exam is a critical step includes fitting a notary public to new nyc this exam is designed to rate your understanding of the laws guidelines and regulations governing notarial acted as shown in the nys notary public site law booklet the exam measures your ability to perform

[notary practice test 1 flashcards quizlet](#) - Oct 26 2021

web 1 which of the following statements is not correct a the fee for a notary public commission is 60 b the secretary of state commissions notaries public c the term of a notary public commission is 2 years d notary public examinations are scheduled throughout nys click the card to flip the term of a notary public commission is 2 years

*free nys notary exam practice 2023 prep guide new york state* - Jul 15 2023

web jan 28 2020 the new york state nys lawyer exam is a critical step in becoming a notary public in new york this exam is considered to evaluation your perception of the laws rules and regulations governing notarial acts as outlined in and nys notary public license law booklet

**free nys notary exam practice 2023 prep guide new york notary public** - Feb 10 2023

web spanish public the nys notary exam is a written tests consisting of 40 multiple choice questions you will be allowed 1 hour till completely the exam they need to score at least 70 instead 28 out of 40 for pass the assessment the questions are based entirely on the new yarn state notary license law

*new york state notary public license exam flashcards quizlet* - Jan 09 2023

web flashcards these flashcards were created from notary public license law the most recent 2013 edition a pdf file from the nys dept of state website download it and try to read it line by line because at least a few obscure details will be on the exam guaranteed

**free nys notary exam practice 2023 prep guide notary practice test** - May 13 2023

web jan 28 2020 free practice test tour open practice the new york state nys notary exam is a critical step in becoming a notary public in new york this exam is designed to assess your understanding of the laws rules and regulations governed notarial shows as outlined included the nys notary public sanction law booklet

[transmission for 1986 suzuki forsa](#) - Jan 01 2022

web jan 13 2018 book suzuki forsa ppt manual book suzuki forsa ppt free access for manual book suzuki forsa ppt from our huge library or simply read online from your

[suzuki sf310 workshop manual cardiagn.com](#) - Jul 07 2022

web manual suzuki forsa 2 business 19 top home audio brands sony manuals philips manuals panasonic manuals jvc manuals pioneer manuals manual suzuki

*manual mecanica automotriz motor suzuki forsa g10* - Apr 16 2023

web warehouseservice manual suzuki forsa gl visiting a brick and mortar library is no longer necessary if you need a novel to read during your daily commute a short stories

**manual mecanica automotriz motor suzuki forsa g10 pdf** - Aug 20 2023

web jan 20 2018 manual book suzuki forsa pdf free access for manual book suzuki forsa pdf from our huge library or simply read online from your computer instantly

**suzuki user manuals download manualslib** - Sep 09 2022

web suzuki sf310 workshop manual this manual contains procedures for diagnosis maintenance adjustments minor service operations replacement of components

[suzuki forsa manual](#) - Apr 04 2022

web complete list of suzuki forenza auto service repair manuals suzuki forenza factory service repair manual fsm 2003 2004 2005 2006 2007 2008

[suzuki forenza repair service manuals 2 pdf s](#) - Mar 03 2022

web manual transmission for 1986 suzuki forsa remanufactured and rebuilt transmissions available call now 888 242 2605 monday friday 9 00am 8 00pm est saturday

**manual for suzuki forsa help environment harvard edu** - Nov 11 2022

web view download of more than 1281 suzuki pdf user manuals service manuals operating guides motorcycle automobile

user manuals operating guides specifications

**manual book suzuki forsa by u943 issuu** - Oct 30 2021

**workshop manual suzuki forsa 1988 2003 workshop manual** - May 17 2023

web manual mecanica automotriz motor suzuki forsa g10 pdf combustión pistón

**suzuki forsa parts accessories carparts com** - Jan 13 2023

web download and install the manual for suzuki forsa it is unconditionally simple then in the past currently we extend the member to buy and create bargains to download and install

*suzuki forenza service repair manuals on motor era* - Feb 02 2022

web sep 20 2017 manual book suzuki forsa pdf free access for manual book suzuki forsa pdf from our huge library or simply read online from your computer instantly

**manual book suzuki forsa glx pdf pdf scribd** - Sep 21 2023

web manual book suzuki forsa glx pdf uploaded by prantomo muhyati copyright all rights reserved available formats

download as pdf txt or read online from scribd

**suzuki workshop service and repair manuals** - Jun 06 2022

web suzuki forsa manual topics subjects topics subjects pauline 21 apr dick c 03 apr 70 items linda l 11 jul brian h 13 aug

suzuki forsa manual created on

**online library manual for suzuki forsa read pdf free** - Oct 10 2022

web gat gat v4

**manual for suzuki forsa pdf copy dedicatedtodio com** - Jun 18 2023

web professional workshop manuals for all types of vehicles includes detailed information easy to understand diagrams and schematics for repairs services and maintenance

*manual suzuki forsa 2* - May 05 2022

web we have 2 suzuki forenza manuals covering a total of 1 years of production in the table below you can see 0 forenza

workshop manuals 0 forenza owners manuals and 1

**suzuki buku parts catalog suzuki forsa** - Feb 14 2023

web studiolidell com redirecting

**manual book suzuki forsa by stephensilvera4668 issuu** - Nov 30 2021

manual for suzuki forsa autoconfig ablogtowatch com - Mar 15 2023

web select your vehicle part our aftermarket suzuki forsa parts and accessories come with a lifetime replacement guarantee free 60 day returns check out our catalog now

**gat** - Aug 08 2022

web free online service and repair manuals for all models forenza l4 2 0l 2004 kizashi awd l4 2 4l 2010 reno l4 2 0l 2006 verona l6 2 5l 2005 aerio

**manual book suzuki forsa by mor1940 issuu** - Jul 19 2023

web manual for suzuki forsa pdf recognizing the showing off ways to acquire this books manual for suzuki forsa pdf is additionally useful you have remained in right site to

**studioliddell com** - Dec 12 2022

web sep 4 2023 as this manual for suzuki forsa it ends occurring living thing one of the favored books manual for suzuki forsa collections that we have this is why you

**krampus playing cards etsy** - Nov 15 2022

web check out our krampus playing cards selection for the very best in unique or custom handmade pieces from our card games shops

**krampus playing cards youtube** - Jan 05 2022

web jan 12 2020 krampus playing cards with 52 cards with vintage design unboxing of playing cards deck and full flip through of the deck its beautiful linen finish card stoc

**krampus cards set 1 youtube** - Aug 12 2022

web the krampus playing cards set 1 which can be used as a tarot deck or oracle if one is able to read playing cards or intuit meanings through images each of

*krampus playing cards set one cards amazon com* - Aug 24 2023

web nov 15 2013 krampus playing cards set one beauchamp monte on amazon com free shipping on qualifying offers krampus playing cards set one

**kindle online pdf krampus playing cards set one for ipad** - Apr 08 2022

web read the latest magazines about kindle online pdf krampus playing cards set one for ipad and discover magazines on yumpu com

[krampus playing cards set two cards sept 1 2017 amazon ca](#) - Sep 13 2022

web a deck of playing cards featuring 52 different krampus images high quality printing and lamination this deck contains an all new set of images different from the first

**krampus playing cards set one cards nov 15 2013 amazon ca** - Jun 22 2023

web krampus playing cards set one beauchamp monte 9780867197921 books amazon ca  
[krampus board game boardgamegeek](#) - May 09 2022

web krampus is a werewolf mafia re theme for the holidays where some players are krampusz a race of alpine christmas demons who abduct naughty children and carry them off to their lair to eat most of the players though are children who are trying to tattletale to the parent the moderator about the right krampusz there are also a variety of other christmas roles  
*krampus card set etsy* - Dec 16 2022

web check out our krampus card set selection for the very best in unique or custom handmade pieces from our blank cards shops

**amazon com customer reviews krampus playing cards set two** - Jul 11 2022

web find helpful customer reviews and review ratings for krampus playing cards set two at amazon com read honest and unbiased product reviews from our users

**krampus playing cards set two cards september 1 2017** - Jul 23 2023

web sep 1 2017 krampus playing cards set two cards september 1 2017 a deck of playing cards featuring 52 different krampus images high quality printing and lamination this deck contains an all new set of images different from the first the images are reproduced from vintage pre wwi krampus postcards

[krampus playing cards 52 vintage designs set one and two](#) - Oct 14 2022

web find many great new used options and get the best deals for krampus playing cards 52 vintage designs set one and two from old postcards at the best online prices at ebay free shipping for many products

**krampus greeting cards set one 20 assorted cards in deluxe tin** - Mar 07 2022

web krampus greeting cards set one 20 assorted cards in deluxe tin 14 ratings arrow drop down 4.9 out of 5 we search the most popular review sites and give you one score you can trust part of the krampus series by monte beauchamp select format hardcover out of stock product is currently out of stock

*krampus playing cards set one krampus playing card deck* - Jun 10 2022

web jun 28 2019 jun 29 2019 krampus playing cards set one beauchamp monte on amazon com free shipping on qualifying offers krampus playing cards set one

**krampus playing cards set one karten 15 november 2013 amazon de** - May 21 2023

web krampus playing cards set one beauchamp monte isbn 9780867197921 kostenloser versand für alle bücher mit versand und verkauf durch amazon

[krampus greeting cards set one 20 assorted cards in deluxe tin](#) - Feb 18 2023

web nov 15 2012 in the early christmas traditions of europe the krampus was st nikolaus dark servant a hairy horned

supernatural beast whose pointed ears and long slithering tongue gave misbehavers the creeps this collection of vintage krampus images includes 20 cards two each of 10 different designs

[krampus playing cards set one cards 15 nov 2013 amazon de](#) - Mar 19 2023

web krampus playing cards set one beauchamp monte amazon de books skip to main content de hello select your address all select the department you want to search in search en hello sign in account lists returns

**9780867197921 krampus playing cards set one abebooks** - Apr 20 2023

web abebooks com krampus playing cards set one 9780867197921 by beauchamp monte and a great selection of similar new used and collectible books available now at great prices 9780867197921 krampus playing cards set one beauchamp monte 0867197927 abebooks

**krampus playing cards set one indigo books music inc** - Jan 17 2023

web buy the paperback book krampus playing cards set one by monte beauchamp at indigo ca canada s largest bookstore free shipping and pickup in store on eligible orders a deck of playing cards featuring 52 different krampus images

*krampus playing cards set one by monte beauchamp* - Feb 06 2022

web may 10th 2020 krampus playing cards set two a deck of playing cards featuring 52 different krampus images high quality printing and lamination this deck mail nocodeapi com 1 10