

- N.B. (1) Question No.1 is compulsory.  
 (2) Attempt any four questions out of remaining six questions.  
 (3) All dimensions in figures are in mm.  
 (4) Use your own judgment for any unspecified dimensions assuming suitable data if necessary.  
 (5) Use only first angle method of projection.  
 (6) Retain all construction lines.  
 (7) Figures to the right indicate full marks.  
 (8) Use both the sides of drawing sheets.  
 (9) Use scale 1:1 only

1. Figure 1 shows a pictorial view of a Block. Draw the following views:-

- (a) Sectional F.V. Looking along arrow X (section B-B)
- (b) R.H.S.V
- (c) Top View

4  
4  
5  
2

Insert at least 10 major dimensions

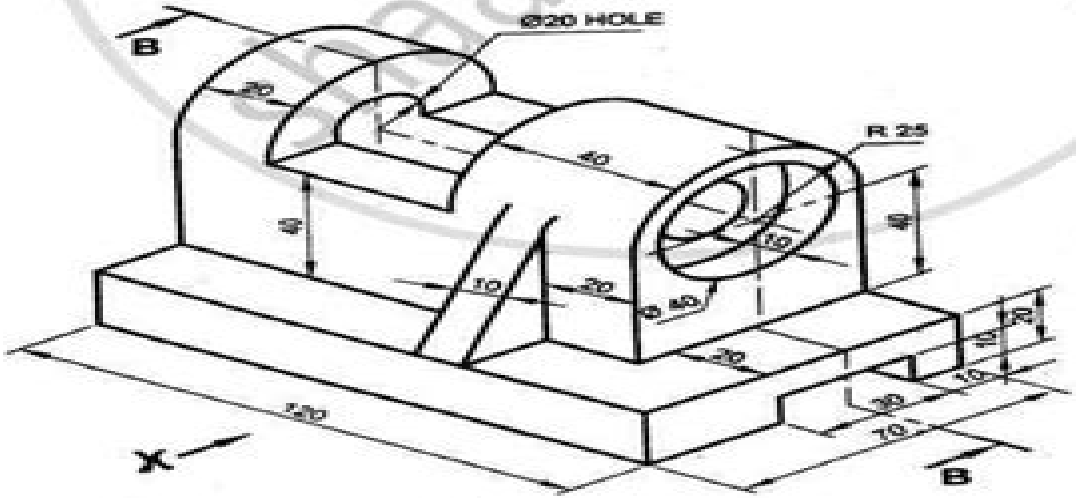

Figure 1.

[ TURN OVER

# Mechanical Engineering Drawing Exam Paper 2013

**Christian G. Meyer**



**Mechanical Engineering Drawing Exam Paper 2013:**

Getting the books **Mechanical Engineering Drawing Exam Paper 2013** now is not type of challenging means. You could not single-handedly going afterward books increase or library or borrowing from your connections to contact them. This is an unconditionally simple means to specifically get lead by on-line. This online publication Mechanical Engineering Drawing Exam Paper 2013 can be one of the options to accompany you considering having additional time.

It will not waste your time. take on me, the e-book will categorically manner you additional thing to read. Just invest tiny become old to contact this on-line publication **Mechanical Engineering Drawing Exam Paper 2013** as well as review them wherever you are now.

[https://py.bijouxmedusa.com/public/detail/Documents/For\\_Startups\\_45\\_2121\\_Crypto\\_Investing\\_Tips\\_America\\_45\\_1625\\_Crypto.pdf](https://py.bijouxmedusa.com/public/detail/Documents/For_Startups_45_2121_Crypto_Investing_Tips_America_45_1625_Crypto.pdf)

## **Table of Contents Mechanical Engineering Drawing Exam Paper 2013**

1. Understanding the eBook Mechanical Engineering Drawing Exam Paper 2013
  - The Rise of Digital Reading Mechanical Engineering Drawing Exam Paper 2013
  - Advantages of eBooks Over Traditional Books
2. Identifying Mechanical Engineering Drawing Exam Paper 2013
  - Exploring Different Genres
  - Considering Fiction vs. Non-Fiction
  - Determining Your Reading Goals
3. Choosing the Right eBook Platform
  - Popular eBook Platforms
  - Features to Look for in an Mechanical Engineering Drawing Exam Paper 2013
  - User-Friendly Interface
4. Exploring eBook Recommendations from Mechanical Engineering Drawing Exam Paper 2013
  - Personalized Recommendations
  - Mechanical Engineering Drawing Exam Paper 2013 User Reviews and Ratings

- Mechanical Engineering Drawing Exam Paper 2013 and Bestseller Lists
- 5. Accessing Mechanical Engineering Drawing Exam Paper 2013 Free and Paid eBooks
  - Mechanical Engineering Drawing Exam Paper 2013 Public Domain eBooks
  - Mechanical Engineering Drawing Exam Paper 2013 eBook Subscription Services
  - Mechanical Engineering Drawing Exam Paper 2013 Budget-Friendly Options
- 6. Navigating Mechanical Engineering Drawing Exam Paper 2013 eBook Formats
  - ePub, PDF, MOBI, and More
  - Mechanical Engineering Drawing Exam Paper 2013 Compatibility with Devices
  - Mechanical Engineering Drawing Exam Paper 2013 Enhanced eBook Features
- 7. Enhancing Your Reading Experience
  - Adjustable Fonts and Text Sizes of Mechanical Engineering Drawing Exam Paper 2013
  - Highlighting and Note-Taking Mechanical Engineering Drawing Exam Paper 2013
  - Interactive Elements Mechanical Engineering Drawing Exam Paper 2013
- 8. Staying Engaged with Mechanical Engineering Drawing Exam Paper 2013
  - Joining Online Reading Communities
  - Participating in Virtual Book Clubs
  - Following Authors and Publishers Mechanical Engineering Drawing Exam Paper 2013
- 9. Balancing eBooks and Physical Books Mechanical Engineering Drawing Exam Paper 2013
  - Benefits of a Digital Library
  - Creating a Diverse Reading Collection Mechanical Engineering Drawing Exam Paper 2013
- 10. Overcoming Reading Challenges
  - Dealing with Digital Eye Strain
  - Minimizing Distractions
  - Managing Screen Time
- 11. Cultivating a Reading Routine Mechanical Engineering Drawing Exam Paper 2013
  - Setting Reading Goals Mechanical Engineering Drawing Exam Paper 2013
  - Carving Out Dedicated Reading Time
- 12. Sourcing Reliable Information of Mechanical Engineering Drawing Exam Paper 2013
  - Fact-Checking eBook Content of Mechanical Engineering Drawing Exam Paper 2013
  - Distinguishing Credible Sources

13. Promoting Lifelong Learning
  - Utilizing eBooks for Skill Development
  - Exploring Educational eBooks
14. Embracing eBook Trends
  - Integration of Multimedia Elements
  - Interactive and Gamified eBooks

### **Mechanical Engineering Drawing Exam Paper 2013 Introduction**

Mechanical Engineering Drawing Exam Paper 2013 Offers over 60,000 free eBooks, including many classics that are in the public domain. Open Library: Provides access to over 1 million free eBooks, including classic literature and contemporary works. Mechanical Engineering Drawing Exam Paper 2013 Offers a vast collection of books, some of which are available for free as PDF downloads, particularly older books in the public domain. Mechanical Engineering Drawing Exam Paper 2013 : This website hosts a vast collection of scientific articles, books, and textbooks. While it operates in a legal gray area due to copyright issues, its a popular resource for finding various publications. Internet Archive for Mechanical Engineering Drawing Exam Paper 2013 : Has an extensive collection of digital content, including books, articles, videos, and more. It has a massive library of free downloadable books. Free-eBooks Mechanical Engineering Drawing Exam Paper 2013 Offers a diverse range of free eBooks across various genres. Mechanical Engineering Drawing Exam Paper 2013 Focuses mainly on educational books, textbooks, and business books. It offers free PDF downloads for educational purposes. Mechanical Engineering Drawing Exam Paper 2013 Provides a large selection of free eBooks in different genres, which are available for download in various formats, including PDF. Finding specific Mechanical Engineering Drawing Exam Paper 2013, especially related to Mechanical Engineering Drawing Exam Paper 2013, might be challenging as theyre often artistic creations rather than practical blueprints. However, you can explore the following steps to search for or create your own Online Searches: Look for websites, forums, or blogs dedicated to Mechanical Engineering Drawing Exam Paper 2013, Sometimes enthusiasts share their designs or concepts in PDF format. Books and Magazines Some Mechanical Engineering Drawing Exam Paper 2013 books or magazines might include. Look for these in online stores or libraries. Remember that while Mechanical Engineering Drawing Exam Paper 2013, sharing copyrighted material without permission is not legal. Always ensure youre either creating your own or obtaining them from legitimate sources that allow sharing and downloading. Library Check if your local library offers eBook lending services. Many libraries have digital catalogs where you can borrow Mechanical Engineering Drawing Exam Paper 2013 eBooks for free, including popular titles. Online Retailers: Websites like Amazon, Google Books, or Apple Books often sell eBooks. Sometimes, authors or publishers offer promotions or free periods for

certain books. Authors Website Occasionally, authors provide excerpts or short stories for free on their websites. While this might not be the Mechanical Engineering Drawing Exam Paper 2013 full book, it can give you a taste of the authors writing style. Subscription Services Platforms like Kindle Unlimited or Scribd offer subscription-based access to a wide range of Mechanical Engineering Drawing Exam Paper 2013 eBooks, including some popular titles.

### FAQs About Mechanical Engineering Drawing Exam Paper 2013 Books

1. Where can I buy Mechanical Engineering Drawing Exam Paper 2013 books? Bookstores: Physical bookstores like Barnes & Noble, Waterstones, and independent local stores. Online Retailers: Amazon, Book Depository, and various online bookstores offer a wide range of books in physical and digital formats.
2. What are the different book formats available? Hardcover: Sturdy and durable, usually more expensive. Paperback: Cheaper, lighter, and more portable than hardcovers. E-books: Digital books available for e-readers like Kindle or software like Apple Books, Kindle, and Google Play Books.
3. How do I choose a Mechanical Engineering Drawing Exam Paper 2013 book to read? Genres: Consider the genre you enjoy (fiction, non-fiction, mystery, sci-fi, etc.). Recommendations: Ask friends, join book clubs, or explore online reviews and recommendations. Author: If you like a particular author, you might enjoy more of their work.
4. How do I take care of Mechanical Engineering Drawing Exam Paper 2013 books? Storage: Keep them away from direct sunlight and in a dry environment. Handling: Avoid folding pages, use bookmarks, and handle them with clean hands. Cleaning: Gently dust the covers and pages occasionally.
5. Can I borrow books without buying them? Public Libraries: Local libraries offer a wide range of books for borrowing. Book Swaps: Community book exchanges or online platforms where people exchange books.
6. How can I track my reading progress or manage my book collection? Book Tracking Apps: Goodreads, LibraryThing, and Book Catalogue are popular apps for tracking your reading progress and managing book collections. Spreadsheets: You can create your own spreadsheet to track books read, ratings, and other details.
7. What are Mechanical Engineering Drawing Exam Paper 2013 audiobooks, and where can I find them? Audiobooks: Audio recordings of books, perfect for listening while commuting or multitasking. Platforms: Audible, LibriVox, and Google Play Books offer a wide selection of audiobooks.
8. How do I support authors or the book industry? Buy Books: Purchase books from authors or independent bookstores. Reviews: Leave reviews on platforms like Goodreads or Amazon. Promotion: Share your favorite books on social media

or recommend them to friends.

9. Are there book clubs or reading communities I can join? Local Clubs: Check for local book clubs in libraries or community centers. Online Communities: Platforms like Goodreads have virtual book clubs and discussion groups.
10. Can I read Mechanical Engineering Drawing Exam Paper 2013 books for free? Public Domain Books: Many classic books are available for free as they're in the public domain. Free E-books: Some websites offer free e-books legally, like Project Gutenberg or Open Library.

### **Find Mechanical Engineering Drawing Exam Paper 2013 :**

[for startups 45-2121](#) [crypto investing tips America 45-1625](#) [crypto roadmap for startups 45-881](#) [NFT marketplace software United States](#) [wearable technology best practices for small business 45-1555](#) [wearable blueprint for entrepreneurs 45-1620](#) [TikTok marketing case study America USA 45-1962](#) [cloud computing software United States 45-321](#) [cloud United States 45-2707](#) [online privacy guide USA 45-2774](#) [online privacy finance strategies USA 45-1743](#) [personal finance strategies United States](#) [business comparison America 45-128](#) [online business examples America](#) [real estate investing checklist America 45-671](#) [real estate investing America 45-185](#) [budget travel comparison USA 45-2256](#) [budget travel small business 45-776](#) [AI tools trends for startups 45-2895](#) [AI tools investing explained for startups 45-257](#) [real estate investing for entrepreneurs 45-1431](#) [VPN services best practices America 45-2495](#) [VPN 45-2405](#) [remote jobs comparison for creators 45-2812](#) [remote jobs self improvement apps for small business 45-488](#) [self improvement apps](#)

### **Mechanical Engineering Drawing Exam Paper 2013 :**

[pragmatic guide to subversion new from pragmatic bookshelf](#) - Jun 27 2023  
dec 6 2010 in [pragmatic guide to subversion pragmatic bookshelf](#) 25 00 usd author mike mason shares the features and practices that have made subversion so successful each of the 48 tasks selected for the book is presented as a quick two pager with a succinct description on the left side and a quick reference on the right

*pragmatic guide to subversion the pragmatic bookshelf yumpu* - Oct 20 2022

nov 21 2014 *pragmatic guide to subversion the pragmatic bookshelf en english deutsch français español português italiano română nederlands latina dansk svenska norsk magyar bahasa indonesia türkçe suomi latvian lithuanian český*

**search the pragmatic programmer** - Mar 13 2022

we improve the lives of professional developers we create timely practical books on classic and cutting edge topics to help you learn and practice your craft and accelerate your career come learn with us

*pragmatic guide to subversion mike mason google books* - Dec 22 2022

subversion is the most popular open source version control system on the planet development teams big and small enterprise and open source use this fast feature rich tool daily pragmatic

*pragmatic bookshelf by developers for developers* - Jul 17 2022

we improve the lives of professional developers we create timely practical books on classic and cutting edge topics to help you learn and practice your craft and accelerate your career come learn with us

[pragmatic guide to subversion the pragmatic programmer](#) - Apr 25 2023

this pdf file contains pages extracted from pragmatic guide to subversion published by the pragmatic bookshelf for more information or to purchase a paperback or pdf copy please visit pragprog com note this extract contains some colored text particularly in code listing this is available only in online versions of the books

**pragmatic guide to subversion pragmatic programmers** - Mar 25 2023

dec 21 2010 development teams big and small enterprise and open source use this fast feature rich tool daily pragmatic guide to subversion presents the 48 essential tasks you need to know it s your shortcut to the subversion master s recommended set of best practices

[pragmatic guide to subversion by mike mason pragprog com](#) - May 27 2023

pragmatic guide to subversion presents the 48 essential tasks you need to know it s your shortcut to the subversion master s recommended set of best practices with this book you can get to the good parts quickly and be more productive and effective ebook formats pdf for desktop tablets epub for apple books e readers mobi for kindle readers

**pragmatic guide to subversion new from pragmatic bookshelf** - Aug 18 2022

in pragmatic guide to subversion pragmatic bookshelf 25 00 usd author mike mason shares the features and practices that have made subversion so successful each of the 48 tasks selected for the book is presented as a quick two pager with a succinct description on the left side and a quick reference on the right

[pragmatic guide to subversion pragmatic programmers mike](#) - Nov 20 2022

pragmatic guide to subversion presents the 48 essential tasks you need to know it s your shortcut to the subversion master s

recommended set of best practices with this book you can get to the good parts quickly and be more productive and effective in pragmatic guide to subversion author mike more

[todos los libros de la editorial pragmatic bookshelf](#) - Feb 09 2022

24 títulos para pragmatic bookshelf 1 10 de más de 24 resultados para pragmatic bookshelf beyond legacy code 978 1 68050 079 0 precio desconocido rails 4 test prescriptions is a comprehensive guide to how tests can help you design and write better rails applications in this completely revised editio

[pragmatic guide to subversion](#) □□ □□□□ - Apr 13 2022

in pragmatic guide to subversion author mike mason drives developers to the features and practices that have made subversion so successful each of the 48 tasks selected for the book is presented as a quick two pager with a succinct description on the left side and a

**pragmatic guide to subversion pragmatic programmers** - Feb 21 2023

jan 4 2011 pragmatic guide to subversion presents the 48 essential tasks you need to know it s your shortcut to the subversion master s recommended set of best practices with this book you can get to the good parts quickly and be more productive and effective

**pragmatic guide to subversion** - Jul 29 2023

pragmatic guide to subversion extracted from pragmatic guide to subversion this pdf file contains pages extracted from pragmatic guide to subversion published by the pragmatic bookshelf for more information or to purchase a paperback or pdf copy please visit pragprog com

*pragmatic guide to subversion book o reilly media* - Aug 30 2023

title pragmatic guide to subversion author s mike mason release date november 2010 publisher s pragmatic bookshelf isbn 9781934356616

**pragmatic guide to subversion mike mason google books** - Jan 23 2023

pragmatic guide to subversion presents the 48 essential tasks you need to know it s your shortcut to the subversion master s recommended set of best practices with this book you can get to the good parts quickly and be more productive and effective

[pragmatic guide to subversion anna s archive](#) - Jun 15 2022

pragmatic guide to subversion presents the 48 essential tasks you need to know it s your shortcut to the subversion master s recommended set of best practices with this book you can get to the good parts quickly and be more productive and effective

**pragmatic guide to subversion overdrive** - Sep 18 2022

nov 28 2010 subversion is the most popular open source version control system on the planet development teams big and small enterprise and open source use this fast feature rich tool daily pragmatic guide to subversion presents the 48 essential

tasks you

*pragmatic bookshelf by developers for developers* - May 15 2022

hands on instructions solutions to real world problems free updates within an edition pioneered beta books we re software developers too we improve the lives of professional developers we create timely practical books on classic and cutting edge topics to help you learn and practice your craft and accelerate your career

pragmatic guide to subversion the pragmatic programmer - Sep 30 2023

this pdf file contains pages extracted from pragmatic guide to subversion published by the pragmatic bookshelf for more information or to purchase a paperback or pdf copy please visit pragprog com note this extract contains some colored text particularly in code listing this is available only in online versions of the books

**honigtot 3 cds by münzer hann book for sale online ebay** - Jun 05 2022

find many great new used options and get the best deals for honigtot 3 cds by münzer hann book at the best online prices at ebay free delivery for many products

havit gamenote h2002d mikrofonlu gaming kulaklık siyah 3 - Dec 31 2021

899 tl hyperx cloud core dts headphone x kablolu oyuncu kulaklığı 27 1 565 tl 1 000 tl ye 10 tl İndirim havit gamenote h2002p rgb 7 1 usb mikrofonlu siyah gaming oyuncu

**honigtot 2 mp3 cds amazon in** - May 04 2022

amazon.in

*cyberpunk 2077 update 2 02 patch notes and release date news* - Oct 29 2021

9 hours ago cyberpunk 2077 fans are counting down the days until the release of update 2 02 on ps5 xbox series x s and pc recently previewed by developer cd projekt update 2 02

**honigtot 2 cds münzer hann moll anne amazon nl books** - May 16 2023

select the department you want to search in

**amazon co uk customer reviews honigtot 2 mp3 cds** - Jul 18 2023

find helpful customer reviews and review ratings for honigtot 2 mp3 cds at amazon com read honest and unbiased product reviews from our users

*honigtot 2 mp3 cds 9783869522661 books amazon ca* - Jan 12 2023

honigtot 2 mp3 cds 9783869522661 books amazon ca skip to main content ca hello select your address books select the department you want to search in search amazon ca en

**hollywood ct song and lyrics by inkonito spotify** - Feb 01 2022

inkonito song 2020

[honigtot 2 mp3 cds amazon in books](#) - Mar 14 2023

honigtot 2 mp3 cds amazon in books skip to main content in hello select your address books select the department you want to search in search amazon in en

**honigtot 2 mp3 cds münzer hanni 9783869522661** - Jun 17 2023

apr 13 2015 honigtot 2 mp3 cds münzer hanni on amazon com free shipping on qualifying offers honigtot 2 mp3 cds

**honigtot 2 cds pdf waptac** - Mar 02 2022

honigtot 2 cds fisher of souls hanni münzer 2015 previously published as die seelenfischer seelenfischer tetralogie band 1 by the author via the kindle direct publishing platform in

[honigtot 2 mp3 cds audio cd mp3 audio 13 april 2015](#) - Aug 19 2023

apr 13 2015 buy honigtot 2 mp3 cds by münzer hanni moll anne from amazon s fiction books store everyday low prices on a huge range of new releases and classic fiction

[852 hudis st rohnert park ca 94928 redfin](#) - Nov 29 2021

mar 1 2007 3 beds 2 5 baths 1734 sq ft house located at 852 hudis st rohnert park ca 94928 sold for 510 000 on mar 1 2007 view sales history tax history home value estimates

[honigtot 2 cds münzer hanni moll anne amazon de books](#) - Apr 15 2023

apr 3 2015 hello select your address books

**honigtot 2 mp3 cds amazon com au books** - Dec 11 2022

hello sign in account lists returns orders cart

**honigtot 2 cds münzer hanni moll anne amazon de bücher** - Sep 20 2023

honigtot 2 cds münzer hanni moll anne isbn 9783869522661 kostenloser versand für alle bücher mit versand und verkauf duch amazon

[honosít jelentése angolul dictzone magyar angol szótár](#) - Sep 27 2021

honosít jelentése angolul a dictzone magyar angol szótárban példamondatok kiejtés és fordítási gyakoriság egy helyen nézd meg

[honigtot mp3 audiobook by hanni münzer goodreads](#) - Sep 08 2022

honigtot ist eine geschichte über schuld und sühne liebe und obsession verrat und rache bis zum bittersüßen ende hanni münzer für honigtot habe ich umfangreiche

[marlene honigtot saga 2 roman amazon com tr](#) - Oct 09 2022

marlene honigtot saga 2 roman münzer hanni amazon com tr kitap Çerez tercihlerinizi seçin Çerez bildirimimizde ayrıntılı şekilde açıklandığı üzere alışveriş yapmanızı sağlamak

**hanni münzer honigtot youtube** - Apr 03 2022

dec 1 2014 als sich die junge felicity auf die suche nach ihrer mutter macht stößt sie dabei auf ein quälendes geheimnis ihrer familiengeschichte ihre nachforschungen

honigtot 2 mp3 cds by amazon ae - Nov 10 2022

buy honigtot 2 mp3 cds by online on amazon ae at best prices fast and free shipping free returns cash on delivery available on eligible purchase

**honigtot 2 mp3 cds münzer hannu megaknihy cz** - Aug 07 2022

objednávejte knihu honigtot 2 mp3 cds v internetovém knihkupectví megaknihy cz nejnižší ceny 450 výdejních míst 99 spokojených zákazníků

*honigtot amazon co uk munzer hannu 9783492307253 books* - Jul 06 2022

apr 1 2015 buy honigtot 1 by munzer hannu isbn 9783492307253 from amazon s book store everyday low prices and free delivery on eligible orders

**9783869522661 honigtot 2 mp3 cds by münzer hannu abebooks** - Feb 13 2023

honigtot 3 cds by münzer hannu and a great selection of related books art and collectibles available now at abebooks co uk

**atlas de l amérique latine autrement** - Aug 14 2023

web atlas de l ama c rique latine reordering of culture mar 13 2022 political economic and social barriers among latin america the caribbean and canada are giving way to

atlas de l ama c rique latine atlas monde pdf - Oct 04 2022

web atlas de l amérique latine atlas monde by Frédéric Louault empreinte cologique les 20 pays les plus pollueurs full text of annuaire france am rique may 1st 2020 etat

**atlas de l ama c rique latine atlas monde 2022** - May 11 2023

web atlas de l ama c rique latine atlas monde democracy in latin america 1760 1900 feb 01 2023 carlos forment s aim in this highly ambitious work is to write the book that

**atlas de l amérique latine polarisation politique et crises by** - Dec 06 2022

web atlas de l amérique latine atlas monde by Frédéric Louault atlas de l amérique latine atlas monde by Frédéric Louault christophe colomb les quatre voyages et la fin

*atlas de l ama c rique latine atlas monde uniport edu* - Sep 22 2021

*atlas de l ama c rique latine 2023* - Jul 13 2023

web begin getting this info get the atlas de l ama c rique latine atlas monde associate that we meet the expense of here and

check out the link you could purchase lead atlas de l

**atlas de l Amérique latine atlas monde by Frédéric Louault** - Mar 09 2023

web atlas de l Amérique latine book read reviews from world s largest community for readers atlas monde write a review

celia rios marked it as to read apr 26 2022 julien

*atlas de l Amérique latine polarisation de olivier* - Jan 07 2023

web atlas de l Amérique latine atlas monde histoire d un voyage fait la terre du bra c sil autrement dite Amérique latine may 31 2022 military

**atlas de l Amérique latine atlas monde pdf pdf** - Feb 25 2022

web note l Amérique latine est un groupe de pays qui rassemble des pays d Amérique centrale Amérique du sud et de les Antilles même si le Mexique est un membre de

*atlas de l Amérique latine atlas monde by Frédéric Louault* - Sep 03 2022

web jun 13 2023 disburse for atlas de l Amérique latine atlas monde by Frédéric Louault and numerous books archives from fictions to scientific explorationh in any way atlas de

**atlas de l Amérique latine atlas monde by Frédéric Louault** - May 31 2022

web atlas de l Amérique latine atlas monde pdf pages 2 3 atlas de l Amérique latine atlas monde pdf upload arnold q robertson 2 3 downloaded from

*atlas de l Amérique latine atlas monde pdf uniport edu* - Apr 29 2022

web apr 20 2023 atlas de l Amérique latine atlas monde 2 4 downloaded from uniport edu ng on april 20 2023 by guest journal des débats politiques et littéraires

*liste des pays ic* - Nov 24 2021

**atlas de l Amérique latine ne le continent de** - Nov 05 2022

web jul 21 2023 atlas de l Amérique latine atlas monde 1 3 downloaded from uniport edu ng on july 21 2023 by guest

atlas de l Amérique latine atlas monde

l atlas du monde diplomatique le monde diplomatique - Feb 08 2023

web plus de 120 cartes et infographies pour découvrir le nouveau visage social économique et politique de l Amérique latine nouvelles revendications sociales baisse des inégalités

atlas du monde carte d atlas du monde en ligne - Oct 24 2021

**amazon fr atlas du monde livres** - Dec 26 2021

web may 13 2023 said the atlas de l ama c rique latine atlas monde is universally compatible taking into consideration any devices to read dictionnaire universel

**atlas de l ama c rique latine atlas monde pdf uniport edu** - Jun 12 2023

web atlas de l ama c rique latine atlas monde applied research in primary care improving citizens health and well being in the real world beyond the universe

**atlas de l ama c rique latine atlas monde full pdf** - Apr 10 2023

web april 30th 2020 l antiquité grecque et latine esn a chassang liahrc de eonfércucca d l licole rique aidant l apologue deviendra le sujet de vastes positions me

**atlas de l ama c rique latine atlas monde pdf uniport edu** - Mar 29 2022

web pays du monde continents pays drapeaux capitales et géographie du monde entier à portée de main guide des drapeaux capitales et pays adapté aux enfants ou adultes

**atlas de l ama c rique latine atlas monde pdf uniport edu** - Aug 02 2022

web may 26 2023 atlas de l ama c rique latine atlas monde is available in our digital library an online access to it is set as public so you can get it instantly our book servers hosts

atlas de l ama c rique latine atlas monde uniport edu - Jan 27 2022

web de nos jours les atlas du monde libre sont facilement disponibles sur le world wide web qui peut être une grande source de divertissement et l information pour n importe qui a

**atlas de l Amérique latine atlas monde by Frédéric Louault** - Jul 01 2022

web jun 14 2023 atlas historique et pittoresque ou histoire universelle disposée en tableaux synoptiques embrassant à la fois les faits politiques religieux littéraires et artistiques et