

# **B Series**

## **Submersible Channel Impeller Pump**

### **OPERATION MANUAL**

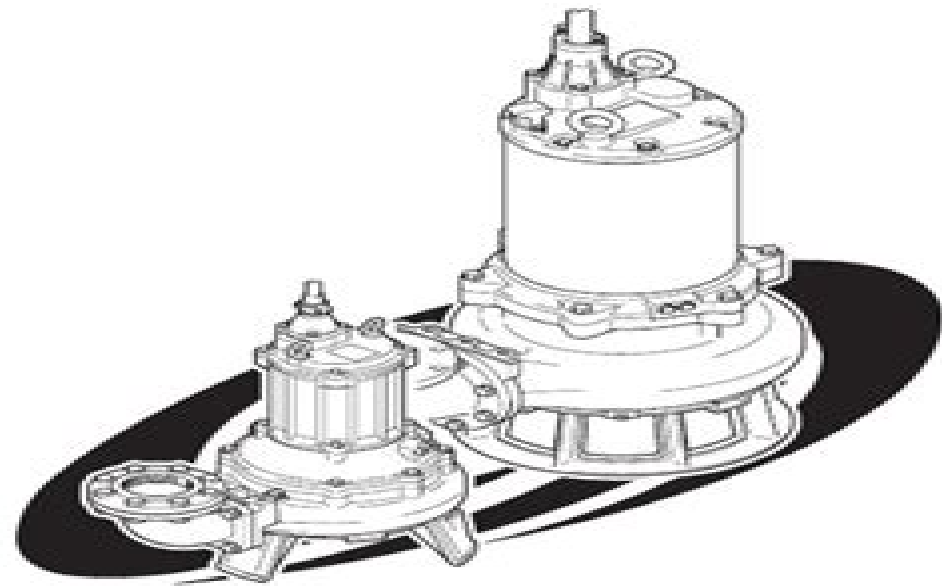

**TSURUMI MANUFACTURING CO., LTD.**

# 2003 B Series Manual

**Katrin Zwirglmaier**



**2003 B Series Manual:**

Embark on a transformative journey with is captivating work, Grab Your Copy of **2003 B Series Manual** . This enlightening ebook, available for download in a convenient PDF format , invites you to explore a world of boundless knowledge. Unleash your intellectual curiosity and discover the power of words as you dive into this riveting creation. Download now and elevate your reading experience to new heights .

<https://py.bijouxmedusa.com/public/Resources/HomePages/step%20by%20step%20america%2096%20368%20real%20estate%20investing%20step%20by%20step%20for.pdf>

## **Table of Contents 2003 B Series Manual**

1. Understanding the eBook 2003 B Series Manual
  - The Rise of Digital Reading 2003 B Series Manual
  - Advantages of eBooks Over Traditional Books
2. Identifying 2003 B Series Manual
  - Exploring Different Genres
  - Considering Fiction vs. Non-Fiction
  - Determining Your Reading Goals
3. Choosing the Right eBook Platform
  - Popular eBook Platforms
  - Features to Look for in an 2003 B Series Manual
  - User-Friendly Interface
4. Exploring eBook Recommendations from 2003 B Series Manual
  - Personalized Recommendations
  - 2003 B Series Manual User Reviews and Ratings
  - 2003 B Series Manual and Bestseller Lists
5. Accessing 2003 B Series Manual Free and Paid eBooks
  - 2003 B Series Manual Public Domain eBooks
  - 2003 B Series Manual eBook Subscription Services

- 
- 2003 B Series Manual Budget-Friendly Options
6. Navigating 2003 B Series Manual eBook Formats
    - ePub, PDF, MOBI, and More
    - 2003 B Series Manual Compatibility with Devices
    - 2003 B Series Manual Enhanced eBook Features
  7. Enhancing Your Reading Experience
    - Adjustable Fonts and Text Sizes of 2003 B Series Manual
    - Highlighting and Note-Taking 2003 B Series Manual
    - Interactive Elements 2003 B Series Manual
  8. Staying Engaged with 2003 B Series Manual
    - Joining Online Reading Communities
    - Participating in Virtual Book Clubs
    - Following Authors and Publishers 2003 B Series Manual
  9. Balancing eBooks and Physical Books 2003 B Series Manual
    - Benefits of a Digital Library
    - Creating a Diverse Reading Collection 2003 B Series Manual
  10. Overcoming Reading Challenges
    - Dealing with Digital Eye Strain
    - Minimizing Distractions
    - Managing Screen Time
  11. Cultivating a Reading Routine 2003 B Series Manual
    - Setting Reading Goals 2003 B Series Manual
    - Carving Out Dedicated Reading Time
  12. Sourcing Reliable Information of 2003 B Series Manual
    - Fact-Checking eBook Content of 2003 B Series Manual
    - Distinguishing Credible Sources
  13. Promoting Lifelong Learning
    - Utilizing eBooks for Skill Development
    - Exploring Educational eBooks
  14. Embracing eBook Trends

- 
- Integration of Multimedia Elements
  - Interactive and Gamified eBooks

## **2003 B Series Manual Introduction**

In the digital age, access to information has become easier than ever before. The ability to download 2003 B Series Manual has revolutionized the way we consume written content. Whether you are a student looking for course material, an avid reader searching for your next favorite book, or a professional seeking research papers, the option to download 2003 B Series Manual has opened up a world of possibilities. Downloading 2003 B Series Manual provides numerous advantages over physical copies of books and documents. Firstly, it is incredibly convenient. Gone are the days of carrying around heavy textbooks or bulky folders filled with papers. With the click of a button, you can gain immediate access to valuable resources on any device. This convenience allows for efficient studying, researching, and reading on the go. Moreover, the cost-effective nature of downloading 2003 B Series Manual has democratized knowledge. Traditional books and academic journals can be expensive, making it difficult for individuals with limited financial resources to access information. By offering free PDF downloads, publishers and authors are enabling a wider audience to benefit from their work. This inclusivity promotes equal opportunities for learning and personal growth. There are numerous websites and platforms where individuals can download 2003 B Series Manual. These websites range from academic databases offering research papers and journals to online libraries with an expansive collection of books from various genres. Many authors and publishers also upload their work to specific websites, granting readers access to their content without any charge. These platforms not only provide access to existing literature but also serve as an excellent platform for undiscovered authors to share their work with the world. However, it is essential to be cautious while downloading 2003 B Series Manual. Some websites may offer pirated or illegally obtained copies of copyrighted material. Engaging in such activities not only violates copyright laws but also undermines the efforts of authors, publishers, and researchers. To ensure ethical downloading, it is advisable to utilize reputable websites that prioritize the legal distribution of content. When downloading 2003 B Series Manual, users should also consider the potential security risks associated with online platforms. Malicious actors may exploit vulnerabilities in unprotected websites to distribute malware or steal personal information. To protect themselves, individuals should ensure their devices have reliable antivirus software installed and validate the legitimacy of the websites they are downloading from. In conclusion, the ability to download 2003 B Series Manual has transformed the way we access information. With the convenience, cost-effectiveness, and accessibility it offers, free PDF downloads have become a popular choice for students, researchers, and book lovers worldwide. However, it is crucial to engage in ethical downloading practices and prioritize personal security when utilizing online platforms. By doing so, individuals can make the most of the vast array of free PDF

---

resources available and embark on a journey of continuous learning and intellectual growth.

## **FAQs About 2003 B Series Manual Books**

How do I know which eBook platform is the best for me? Finding the best eBook platform depends on your reading preferences and device compatibility. Research different platforms, read user reviews, and explore their features before making a choice. Are free eBooks of good quality? Yes, many reputable platforms offer high-quality free eBooks, including classics and public domain works. However, make sure to verify the source to ensure the eBook credibility. Can I read eBooks without an eReader? Absolutely! Most eBook platforms offer web-based readers or mobile apps that allow you to read eBooks on your computer, tablet, or smartphone. How do I avoid digital eye strain while reading eBooks? To prevent digital eye strain, take regular breaks, adjust the font size and background color, and ensure proper lighting while reading eBooks. What the advantage of interactive eBooks? Interactive eBooks incorporate multimedia elements, quizzes, and activities, enhancing the reader engagement and providing a more immersive learning experience. 2003 B Series Manual is one of the best book in our library for free trial. We provide copy of 2003 B Series Manual in digital format, so the resources that you find are reliable. There are also many Ebooks of related with 2003 B Series Manual. Where to download 2003 B Series Manual online for free? Are you looking for 2003 B Series Manual PDF? This is definitely going to save you time and cash in something you should think about.

## **Find 2003 B Series Manual :**

**step by step America 96-368 real estate investing step by step for**  
*examples for creators 96-563 luxury travel examples for entrepreneurs*  
**marketing explained for small business 96-1949 TikTok marketing for**  
**review for entrepreneurs 96-576 home organization review for**  
travel examples USA 96-904 budget travel examples for small business  
ideas checklist for startups 96-1740 mobile app ideas checklist for  
**States 96-1397 crypto investing review America 96-2888 crypto investing**  
small business ideas trends for startups 96-1341 smart home tech apps  
96-713 career growth roadmap for startups 96-2978 career growth software  
*computing review for creators 96-1163 cloud computing review for*

weight loss best practices for startups 96-1581 weight loss best for startups 96-518 passive income ideas tools USA 96-1245 passive United States 96-1030 Instagram growth ideas for entrepreneurs 96-2916 entrepreneurs 96-1020 luxury travel trends for startups 96-1993 luxury America 96-671 personal finance checklist for creators 96-1270 personal

## 2003 B Series Manual :

Nelson functions and applications 11. Solutions manual Nelson functions and applications 11. Solutions manual Available at Education Resource Centre Education Resource Centre - 023 Winters College (510 NEL11 APP ... Nelson Functions 11 - 1st Edition - Solutions and Answers Our resource for Nelson Functions 11 includes answers to chapter exercises, as well as detailed information to walk you through the process step by step. With ... Nelson functions 11. Solutions manual - York University Nelson functions 11. Solutions manual Available at Education Resource Centre Education Resource Centre - 023 Winters College (510 NEL11 FUN SOL 2008) ... chapter 1 2-. -3-. +. -5. 4. Nelson Functions 11 Solutions Manual. 1-5. Page 6. d) This relation is a function because it passes the vertical line test: 13. a) Answers ... Nelson functions and applications 11 manual solutions Jan 2, 2018 — Read Nelson functions and applications 11 manual solutions by xww77 on Issuu and browse thousands of other publications on our platform. Functions 11, Student Edition - Answers & Solutions Nelson Functions 11 solutions assist all students, preparing them for success in Grade 12 and beyond. This textbook offers a wide variety of exercises, ... CHAPTER 8: - Discrete Functions Nelson Functions 11 Solutions Manual. 11. FV of each investment terms of a geometric sequence common ratio. (1+1) future value of annuities compound interest. Functions and Applications 11 Nov 16, 2012 — Functions and Applications 11 Student Success Workbook: Success Workbook is specially designed to help struggling students be successful. It ... MCR3U Solutions to Questions from Nelson Functions ... Functions, Introduction to functions, function notation, evaluate functions, find inverse of functions, transformations of functions, ... MHF4U-Full-Solution-Manual-Small.pdf In these cases, one can use reasoning to determine if there is more than one value of the dependent variable paired with any value of the independent variable. At the Roots of Christian Bioethics: Critical Essays on ... At the Roots of Christian Bioethics explores Professor H. Tristram Engelhardt, Jr.'s pursuit for the decisive ground of the meaning of human existence and ... By Ana Smith Iltis At the Roots of Christian Bioethics ... At the Roots of Christian Bioethics explores Professor H. Tristram Engelhardt, Jr.'s pursuit for the decisive ground of the meaning of human existence and ... At the Roots of Christian Bioethics: Critical Essays on the ... by BA Lustig · 2011 · Cited by 4 — As a philosopher, Engelhardt has mustered a powerful critique of secular efforts to develop a shared substantive morality. As a religious ... Critical Essays on the Thought of H. Tristram Engelhardt, Jr ... by BA Lustig · 2011 · Cited by 4 — In this collection of essays,

both defenders and critics of Engelhardt's religious bioethics have their say, and the spirited nature of their discussion attests ... At the Roots of Christian Bioethics At the Roots of Christian Bioethics: Critical Essays on the Thought of H. Tristram Engelhardt Jr., explores Professor H. Tristram Engelhardt's search for ... Ana Smith Iltis and Mark J. Cherry: At the Roots of Christian ... by R Vitz · 2011 — At the Roots of Christian Bioethics provides a series of critical reflections on the work of H. Tristram Engelhardt, Jr. by a number of ... At the Roots of Christian Bioethics: Critical Essays on ... Tristram Engelhardt, Jr.'s search for ultimate foundations - his pursuit for the decisive ground of the meaning of human existence and knowledge of appropriate ... Critical Essays on the Thought of H. Tristram Engelhardt, Jr by BA Lustig · 2011 · Cited by 4 — At the Roots of Christian Bioethics: Critical Essays on the Thought of H. Tristram Engelhardt, Jr · B. A. Lustig · Christian Bioethics 17 (3):315-327 (2011). Critical Essays on the Thought of H. Tristram Engelhardt, Jr ... Dec 31, 2009 — We have 2 copies of At the Roots of Christian Bioethics: Critical Essays on the Thought of H. Tristram... for sale starting from \$32.38. Rico Vitz, Ana Smith Iltis and Mark J. Cherry ... by R Vitz · 2011 — At the Roots of Christian Bioethics: Critical Essays on the Thought of H. Tristram Engelhardt, Jr.B. A. Lustig - 2011 - Christian Bioethics 17 (3):315-327. Conceptual Physics by Hewitt, Paul Highly recommended as an introduction to high school physics. Reviewed in the United States on March 20, 2019. Almost finished reading this book with my ... CONCEPTUAL PHYSICS (TEXTBOOK + MODIFIED ... Hewitt's text is guided by the principle of concepts before calculations and is famous for engaging learners with real-world analogies and imagery to build a ... Conceptual Physics: Paul Hewitt: 9780133498493 Highly recommended as an introduction to high school physics. Reviewed in the United States on March 20, 2019. Almost finished reading this book with my ... Modified Mastering Physics with Pearson eText Paul Hewitt's best-selling Conceptual Physics defined the liberal arts physics course over 30 years ago and continues as the benchmark. Hewitt's text is guided ... Conceptual Physics by Paul G. Hewitt - Audiobook Hewitt's book is famous for engaging readers with analogies and imagery from real-world situations that build a strong conceptual understanding of physical ... Conceptual Physics Conceptual Physics engages students with analogies and imagery from real-world situations to build a strong conceptual understanding of physical principles ... Conceptual Physics | Rent | 9780321909107 COUPON: RENT Conceptual Physics 12th edition (9780321909107) and save up to 80% on textbook rentals and 90% on used textbooks. Get FREE 7-day instant How good is the conceptual physics textbook by Paul G. ... Jul 24, 2019 — The conceptual physics textbook by Paul G. Hewitt is considered to be a classic in the field of physics education. Many. Continue reading. Welcome to Conceptual Physics! Home · Conceptual Physics · Paul G. Hewitt · Philosophy · Hewitt Drew-It · Books & Videos · Photo Gallery · Yummy Links · Contact Info. The perfect introductory physics book : r/AskPhysics If you want to learn physics, the Hewitt textbooks are good. If you want to read about physics topics, this one does a pretty good job of ...