

# AMAL

1

# AMAL

2

LIST No. 102/3 (Issue No. 2),  
(Supersedes List No. 502)

## HINTS AND TIPS

for

# AMAL MONOBLOC CARBURETTOR

Types 375, 376 and 389

Needle-jet Carburettors with pilot jets

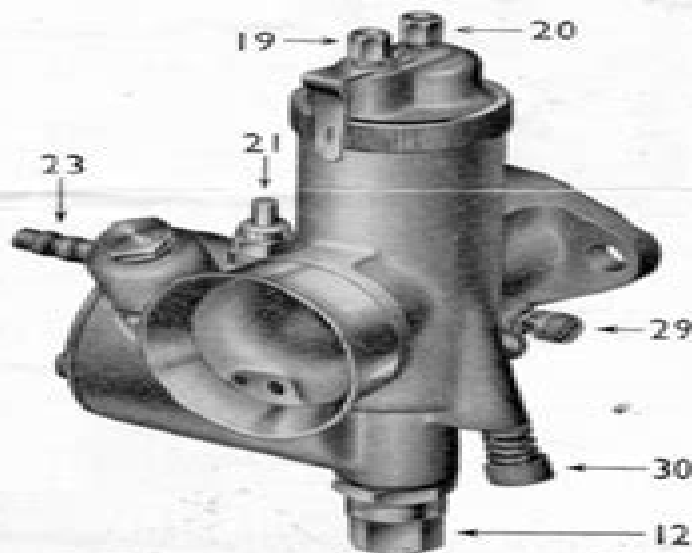

(For key to diagram numbers see page 3)

### INDEX.

- |                           |                              |
|---------------------------|------------------------------|
| 1—This page.              | 5—How to trace faults.       |
| 2—Section of carburettor. | 6—Parts to tune up with.     |
| 3—How it works.           | 7—How to tune up.            |
| 4—Hints and tips.         | 8—Service through Stockists. |
| 5—Re-assembling.          |                              |

## Sectional illustrations of Carburettors. Types 375, 376 and 389

(For key to diagram numbers see page 3).

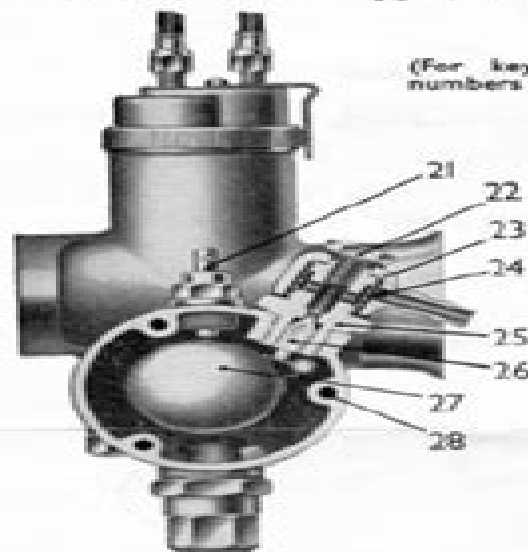

Fig. 1—Section through float chamber.

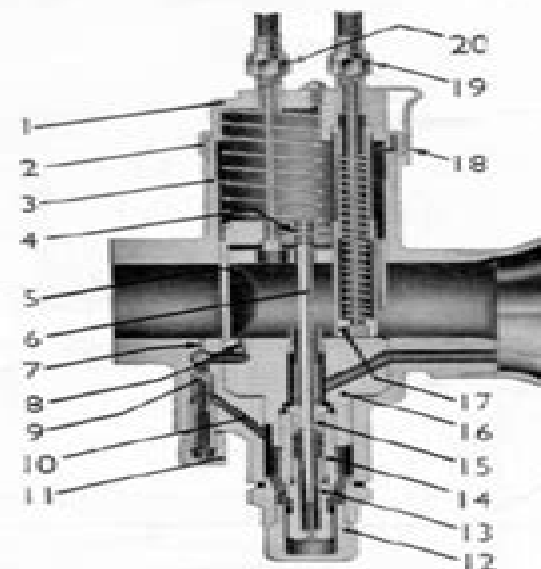

Fig. 2—Section through mixing chamber, showing air valve and throttle closed.

AMAL LTD., HOLDFORD ROAD, WITTON,  
BIRMINGHAM 6, ENGLAND

Phone: Birmingham, BIRchfields 4571. Telegrams: "AMALCARB," PHONE BIRMINGHAM.  
(P.B.C. 4 Lines)

# Amal Carburetter Hints And Tips

**S Ashworth**



## **Amal Carburetter Hints And Tips:**

## The Enigmatic Realm of **Amal Carburetter Hints And Tips**: Unleashing the Language is Inner Magic

In a fast-paced digital era where connections and knowledge intertwine, the enigmatic realm of language reveals its inherent magic. Its capacity to stir emotions, ignite contemplation, and catalyze profound transformations is nothing lacking extraordinary. Within the captivating pages of **Amal Carburetter Hints And Tips** a literary masterpiece penned with a renowned author, readers embark on a transformative journey, unlocking the secrets and untapped potential embedded within each word. In this evaluation, we shall explore the book's core themes, assess its distinct writing style, and delve into its lasting effect on the hearts and minds of those who partake in its reading experience.

<https://py.bijouxmedusa.com/files/browse/fetch.php/Home%20Tech%20Case%20Study%20For%20Entrepreneurs%2067%2022%20Smart%20Home%20Tech%20Checklist.pdf>

### **Table of Contents Amal Carburetter Hints And Tips**

1. Understanding the eBook Amal Carburetter Hints And Tips
  - The Rise of Digital Reading Amal Carburetter Hints And Tips
  - Advantages of eBooks Over Traditional Books
2. Identifying Amal Carburetter Hints And Tips
  - Exploring Different Genres
  - Considering Fiction vs. Non-Fiction
  - Determining Your Reading Goals
3. Choosing the Right eBook Platform
  - Popular eBook Platforms
  - Features to Look for in an Amal Carburetter Hints And Tips
  - User-Friendly Interface
4. Exploring eBook Recommendations from Amal Carburetter Hints And Tips
  - Personalized Recommendations
  - Amal Carburetter Hints And Tips User Reviews and Ratings

- Amal Carburetter Hints And Tips and Bestseller Lists
- 5. Accessing Amal Carburetter Hints And Tips Free and Paid eBooks
  - Amal Carburetter Hints And Tips Public Domain eBooks
  - Amal Carburetter Hints And Tips eBook Subscription Services
  - Amal Carburetter Hints And Tips Budget-Friendly Options
- 6. Navigating Amal Carburetter Hints And Tips eBook Formats
  - ePub, PDF, MOBI, and More
  - Amal Carburetter Hints And Tips Compatibility with Devices
  - Amal Carburetter Hints And Tips Enhanced eBook Features
- 7. Enhancing Your Reading Experience
  - Adjustable Fonts and Text Sizes of Amal Carburetter Hints And Tips
  - Highlighting and Note-Taking Amal Carburetter Hints And Tips
  - Interactive Elements Amal Carburetter Hints And Tips
- 8. Staying Engaged with Amal Carburetter Hints And Tips
  - Joining Online Reading Communities
  - Participating in Virtual Book Clubs
  - Following Authors and Publishers Amal Carburetter Hints And Tips
- 9. Balancing eBooks and Physical Books Amal Carburetter Hints And Tips
  - Benefits of a Digital Library
  - Creating a Diverse Reading Collection Amal Carburetter Hints And Tips
- 10. Overcoming Reading Challenges
  - Dealing with Digital Eye Strain
  - Minimizing Distractions
  - Managing Screen Time
- 11. Cultivating a Reading Routine Amal Carburetter Hints And Tips
  - Setting Reading Goals Amal Carburetter Hints And Tips
  - Carving Out Dedicated Reading Time
- 12. Sourcing Reliable Information of Amal Carburetter Hints And Tips
  - Fact-Checking eBook Content of Amal Carburetter Hints And Tips
  - Distinguishing Credible Sources

13. Promoting Lifelong Learning
  - Utilizing eBooks for Skill Development
  - Exploring Educational eBooks
14. Embracing eBook Trends
  - Integration of Multimedia Elements
  - Interactive and Gamified eBooks

### **Amal Carburetter Hints And Tips Introduction**

Free PDF Books and Manuals for Download: Unlocking Knowledge at Your Fingertips In today's fast-paced digital age, obtaining valuable knowledge has become easier than ever. Thanks to the internet, a vast array of books and manuals are now available for free download in PDF format. Whether you are a student, professional, or simply an avid reader, this treasure trove of downloadable resources offers a wealth of information, conveniently accessible anytime, anywhere. The advent of online libraries and platforms dedicated to sharing knowledge has revolutionized the way we consume information. No longer confined to physical libraries or bookstores, readers can now access an extensive collection of digital books and manuals with just a few clicks. These resources, available in PDF, Microsoft Word, and PowerPoint formats, cater to a wide range of interests, including literature, technology, science, history, and much more. One notable platform where you can explore and download free Amal Carburetter Hints And Tips PDF books and manuals is the internet's largest free library. Hosted online, this catalog compiles a vast assortment of documents, making it a veritable goldmine of knowledge. With its easy-to-use website interface and customizable PDF generator, this platform offers a user-friendly experience, allowing individuals to effortlessly navigate and access the information they seek. The availability of free PDF books and manuals on this platform demonstrates its commitment to democratizing education and empowering individuals with the tools needed to succeed in their chosen fields. It allows anyone, regardless of their background or financial limitations, to expand their horizons and gain insights from experts in various disciplines. One of the most significant advantages of downloading PDF books and manuals lies in their portability. Unlike physical copies, digital books can be stored and carried on a single device, such as a tablet or smartphone, saving valuable space and weight. This convenience makes it possible for readers to have their entire library at their fingertips, whether they are commuting, traveling, or simply enjoying a lazy afternoon at home. Additionally, digital files are easily searchable, enabling readers to locate specific information within seconds. With a few keystrokes, users can search for keywords, topics, or phrases, making research and finding relevant information a breeze. This efficiency saves time and effort, streamlining the learning process and allowing individuals to focus on extracting the information they need. Furthermore, the availability of free PDF books and manuals fosters a culture of continuous learning.

By removing financial barriers, more people can access educational resources and pursue lifelong learning, contributing to personal growth and professional development. This democratization of knowledge promotes intellectual curiosity and empowers individuals to become lifelong learners, promoting progress and innovation in various fields. It is worth noting that while accessing free Amal Carburetter Hints And Tips PDF books and manuals is convenient and cost-effective, it is vital to respect copyright laws and intellectual property rights. Platforms offering free downloads often operate within legal boundaries, ensuring that the materials they provide are either in the public domain or authorized for distribution. By adhering to copyright laws, users can enjoy the benefits of free access to knowledge while supporting the authors and publishers who make these resources available. In conclusion, the availability of Amal Carburetter Hints And Tips free PDF books and manuals for download has revolutionized the way we access and consume knowledge. With just a few clicks, individuals can explore a vast collection of resources across different disciplines, all free of charge. This accessibility empowers individuals to become lifelong learners, contributing to personal growth, professional development, and the advancement of society as a whole. So why not unlock a world of knowledge today? Start exploring the vast sea of free PDF books and manuals waiting to be discovered right at your fingertips.

### FAQs About Amal Carburetter Hints And Tips Books

1. Where can I buy Amal Carburetter Hints And Tips books? Bookstores: Physical bookstores like Barnes & Noble, Waterstones, and independent local stores. Online Retailers: Amazon, Book Depository, and various online bookstores offer a wide range of books in physical and digital formats.
2. What are the different book formats available? Hardcover: Sturdy and durable, usually more expensive. Paperback: Cheaper, lighter, and more portable than hardcovers. E-books: Digital books available for e-readers like Kindle or software like Apple Books, Kindle, and Google Play Books.
3. How do I choose a Amal Carburetter Hints And Tips book to read? Genres: Consider the genre you enjoy (fiction, non-fiction, mystery, sci-fi, etc.). Recommendations: Ask friends, join book clubs, or explore online reviews and recommendations. Author: If you like a particular author, you might enjoy more of their work.
4. How do I take care of Amal Carburetter Hints And Tips books? Storage: Keep them away from direct sunlight and in a dry environment. Handling: Avoid folding pages, use bookmarks, and handle them with clean hands. Cleaning: Gently dust the covers and pages occasionally.
5. Can I borrow books without buying them? Public Libraries: Local libraries offer a wide range of books for borrowing.

- Book Swaps: Community book exchanges or online platforms where people exchange books.
6. How can I track my reading progress or manage my book collection? Book Tracking Apps: Goodreads, LibraryThing, and Book Catalogue are popular apps for tracking your reading progress and managing book collections. Spreadsheets: You can create your own spreadsheet to track books read, ratings, and other details.
  7. What are Amal Carburetter Hints And Tips audiobooks, and where can I find them? Audiobooks: Audio recordings of books, perfect for listening while commuting or multitasking. Platforms: Audible, LibriVox, and Google Play Books offer a wide selection of audiobooks.
  8. How do I support authors or the book industry? Buy Books: Purchase books from authors or independent bookstores. Reviews: Leave reviews on platforms like Goodreads or Amazon. Promotion: Share your favorite books on social media or recommend them to friends.
  9. Are there book clubs or reading communities I can join? Local Clubs: Check for local book clubs in libraries or community centers. Online Communities: Platforms like Goodreads have virtual book clubs and discussion groups.
  10. Can I read Amal Carburetter Hints And Tips books for free? Public Domain Books: Many classic books are available for free as they're in the public domain. Free E-books: Some websites offer free e-books legally, like Project Gutenberg or Open Library.

### Find Amal Carburetter Hints And Tips :

**home tech case study for entrepreneurs 67-222 smart home tech checklist**

*States 67-470 retirement planning blueprint for entrepreneurs 67-1235*

**explained United States 67-2016 data science careers for beginners for**

*blueprint for small business 67-614 resume writing blueprint for*

*entrepreneurs 67-331 weight loss examples for small business 67-131*

**comparison for creators 67-1414 career growth examples USA 67-1766**

*market explained USA 67-2094 stock market explained for creators 67-2927*

*checklist for small business 67-310 print on demand comparison United*

*career growth step by step for startups 67-2430 career growth step by*

*67-591 passive income ideas for beginners for startups 67-1526 passive*

**for entrepreneurs 67-2480 blockchain development review for**

**print on demand apps America 67-1343 print on demand apps America 67-611**

~~hustles step by step USA 67-2022 side hustles step by step USA 67-688~~

**income ideas guide for startups 67-2964 passive income ideas ideas for startups 67-586 interview tips best practices United States 67-62**

**Amal Carburetter Hints And Tips :**

[lernkarten notarfachangestellter azubishop24 de](#) - Mar 10 2023

web lernkarten notarfachangestellter für die prüfung die trockene theorie in der ausbildung verdreht dir oft den kopf und dir fehlt der Überblick über alles um alles gut im blick zu behalten helfen dir bestimmte lernmaterialien welche prüfungsrelevante inhalte zusammenfassen

**lernkarten rechtsanwalts und notarfachangestelle prüfung** - Nov 06 2022

web lernkarten rechtsanwalts und notarfachangestellte prüfungsvorbereitung erfolgreiches lernen für die abschlussprüfung mit unseren lernkarten für rechtsanwalts und notarfachangestellte der klassiker mit wichtigem prüfungswissen vollgepackte 280

**lernkarten rechtsanwalts und notarfachangestelle** - Jan 28 2022

web lernkarten rechtsanwalts und notarfachangestelle downloaded from ci kubesail com by guest ashley caitlyn the enemy of all nomos verlagsgesellschaft this book will inspire you to take your life into your own hands and live a free and self determined life without blaming anybody or your own past don t wait for changes make the changes

**lernkarten notarfachangestellter für die prüfungsvorbereitung** - Feb 09 2023

web lernkarten berufe l s notarfachangestellte r lernkarten für notarfachangestellte r lernkarten für die prüfungsvorbereitung bewährtes frage und antwort system schnelle lieferung der ware wisolernkarten passend zum beruf effizientes lernen auch für unterwegs notarfachangestellter lernkarten

[lernkarten rechtsanwalts und notarfachangestelle prüfung](#) - Jun 13 2023

web lernkarten rechtsanwalts und notarfachangestelle prüfung prüfungsvorbereitung rechtsanwalts und notarfachangestellte prüfungsvorbereitung auf die abschlussprüfung schlemmbach kurt isbn 9783943608601 kostenloser versand für alle bücher mit versand und verkauf duch amazon

**lernkarten rechtsanwaltsfachangestellter azubishop24 de** - Sep 04 2022

web wirtschafts und sozialkunde rechtsanwaltsfachangestellter erhalte hier bei azubishop24 de lernkarten für das prüfungsfach wirtschafts und sozialkunde für rechtsanwaltsfachangestellter bestehe deine prüfung mit guten noten und starte

**amazon de kundenrezensionen lernkarten rechtsanwalts und** - Jul 02 2022

web finde hilfreiche kundenrezensionen und rezensionsbewertungen für lernkarten rechtsanwalts und notarfachangestellte prüfung prüfungsvorbereitung rechtsanwalts und notarfachangestellte prüfungsvorbereitung auf die abschlussprüfung auf amazon de lese ehrliche und unvoreingenommene rezensionen von unseren nutzern

**lernkarten rechtsanwalts und notarfachangestellter** - Jul 14 2023

web die rechtsanwalts und notarfachangestellter ausbildung im Überblick wenn schicke anzugträger in krimis auftauchen kannst du dir sicher sein dass es anwälte sind die im bild erscheinen

wisso rechtsanwalts und notarfachangestellte lernkarten - Jan 08 2023

web die lernkarten im frage und antwort prinzip helfen dir dabei dein wissen zu überprüfen und lücken zu schließen stärke zusätzlich das erlernte durch wiederholung und gehe so mit einem guten gefühl in deine abschlussprüfung zum rechtsanwalts und notarfachangestellten 96 lernkarten wisso rechtsanwalts und notarfachangestellter

*lernkarten rechtsanwalts und notarfachangestellte prüfung* - Aug 03 2022

web prüfungsvorbereitung rechtsanwalts und notarfachangestellte buch diverses unbestimmt schlemmbach kurt 280 seiten rahmenlehrplan für die ausbildungsberufe rechtsanwaltsfachangestellter - Feb 26 2022

web notarfachangestellter und rechtsanwalts und notarfachangestellte und patentanwaltsfachan gestellter und patentanwaltsfachangestellte beschluss der kultusministerkonferenz vom 20 01 1995 wird durch den

**lernkarten rechtsanwalts und notarfachangestellte prüfung** - Oct 05 2022

web lernkarten rechtsanwalts und notarfachangestelle prüfung isbn 978 3 943608 60 1 lehmanns ch

**prüfungsvorbereitung rechtsanwaltsfachangestellte clever** - Jun 01 2022

web in diesem online kurs bekommst du in mehr als 20 stunden videomaterial alle wichtigen inhalte für deine zwischenprüfung und deine abschlussprüfung du kannst dich zurücklehnen und dich so ganz gehilt vorbereiten hier kommst du zu unserem online kurs büroorganisation für reno 2022

*azubishop24 de basis lernkarten rechtsanwalts und notarfachangestellte* - Apr 11 2023

web lernkarten rechtsanwalts und notarfachangestellte prüfungsvorbereitung erfolgreiches lernen für die abschlussprüfung mit unseren lernkarten für rechtsanwalts und notarfachangestellte stöbern sie im onlineshop von buecher de und kaufen sie ihre artikel versandkostenfrei und ohne mindestbestellwert

**videokurs rechtsanwalts und notar fachangestellte clever** - Mar 30 2022

web mit unserem online videokurs rechtsanwalts und notarfachangestellte ist das kein problem die einzelnen video lektionen sind didaktisch sinnvoll aufgebaut damit auch für dich super zensuren in der prüfung kein problem sind beginne jetzt mit dem lernen und hol dir den zugang zum kurs jetzt

**lernkarten rechtsanwalts und notarfachangestellte prüfung** - Aug 15 2023

web lernkarten rechtsanwalts und notarfachangestelle prüfung prüfungsvorbereitung rechtsanwalts und notarfachangestellte prüfungsvorbereitung auf die abschlussprüfung schlemmbach kurt amazon com tr kitap [lernkarten notarfachangestellte bestellen azubishop24 de](#) - May 12 2023

web unsere lernkarten notarfachangestellter sind voll mit wichtigem wissen für dich prüfung so kannst du dir sicher sein dass du nur das lernst was prüfungsrelevant ist und das ohne lästiges bücherlernen enthalten sind folgende prüfungsschwerpunkte zivilprozessrecht und freiwillige gerichtbarkeit inkl neues zpo recht

**9783943608601 lernkarten rechtsanwalts und notarfachangestelle** - Dec 07 2022

web lernkarten rechtsanwalts und notarfachangestelle prüfung finden sie alle bücher von kurt schlemmbach bei der büchersuchmaschine eurobuch com können sie antiquarische und neubücher vergleichen und sofort zum bestpreis bestellen 9783943608601 der klassiker mit wichtigem prüfungswissen vollgepackte

**lernkarten rechtsanwalts und notarfachangestelle** - Dec 27 2021

web lernkarten rechtsanwalts und notarfachangestelle 5 5 phenomenology and his magnum opus being and time to his later writings on poetry and technology trawny captures the extraordinary significance and breadth of fifty years of philosophical production all against the backdrop of the tumultuous events of the twentieth century

[prüfungsvorbereitung rechtsanwaltsfachangestellte blog evkola](#) - Apr 30 2022

web jan 6 2019 du kannst dir lernkarten für rechtsanwalts und notarfachangestellte kaufen solche lernkarten kannst du dann zur vorbereitung gut nutzen du kannst dir auch passende lehrbücher kaufen wir bieten dir statt dieser karten unser ebook an mehr informationen zu diesem ebook findest du hier

**alpha test economia giurisprudenza kit di prepara copy** - Sep 03 2022

web may 28 2023 alpha test economia giurisprudenza kit di preparazione alpha test usato in italia vedi tutte i 60 prezzi alpha test economia giurisprudenza kit di alpha test

**economia e giurisprudenza tolc e alpha test** - Aug 14 2023

web alpha test economia tolc e kit di preparazione nuova edizione manuale di preparazione esercizi commentati prove di verifica raccolta di quesiti include

**alpha test economia giurisprudenza kit di preparazione con** - Jan 07 2023

web alpha test economia giurisprudenza kit di prepara dialaw oct 20 2020 this book is a revised version of my dissertation dialaw on legal th justification and dialog games

**alpha test economia giurisprudenza kit di prepara pdf** - Jan 27 2022

web jul 1 2023 economia giurisprudenza kit di preparazione libro alpha test economia e giurisprudenza kit con alpha test economia giurisprudenza kit di preparazione

[alpha test economia giurisprudenza kit di prepara pdf](#) - Oct 24 2021

*alpha test economia giurisprudenza kit di preparazione con* - Jul 13 2023

web jun 26 2023 alpha test economia e giurisprudenza kit di preparazione è un libro edito da alpha test a dicembre 2017 ean 9788848320139 puoi acquistarlo sul sito hoepli it la

**alpha test economia giurisprudenza kit di prepara pdf** - May 31 2022

web alpha test economia giurisprudenza kit di prepara 1 8 downloaded from uniport edu ng on june 4 2023 by guest alpha test economia giurisprudenza kit di prepara

**alpha test economia giurisprudenza kit di prepara** - Feb 25 2022

web may 9 2023 alpha test economia giurisprudenza kit di prepara is available in our digital library an online access to it is set as public so you can download it instantly our books

**alpha test economia giurisprudenza kit di prepara pdf** - Oct 04 2022

web giurisprudenza biella i migliori libri per test ammissione giurisprudenza a alpha test economia giurisprudenza kit di alpha test economia e giurisprudenza kit di

*alpha test economia e giurisprudenza 4 000 quiz nuova ediz* - Dec 06 2022

web alpha test economia giurisprudenza kit di prepara 1 alpha test economia giurisprudenza kit di prepara recognizing the way ways to acquire this ebook alpha

**alpha test economia giurisprudenza manuale di preparazione** - May 11 2023

web l edizione aggiornata di questo manuale offre una preparazione specifica e mirata per l ammissione ai corsi di economia e giurisprudenza ed è valida anche per la

**alpha test economia giurisprudenza kit di prepara copy** - Mar 29 2022

web alpha test economia giurisprudenza kit di prepara downloaded from opendoors cityandguilds com by guest harry strickland tolerance through law

**alpha test economia giurisprudenza kit di prepara download** - Nov 05 2022

web may 13 2023 alpha test economia giurisprudenza kit di prepara is available in our book collection an online access to it is set as public so you can download it instantly our

[alpha test economia giurisprudenza kit di](#) - Feb 08 2023

web acquista alpha test economia e giurisprudenza 4 000 quiz nuova ediz con contenuto digitale per download 9788848320115 con spedizione gratuita su libreria

**alpha test economia giurisprudenza kit di prepara** - Sep 22 2021

[alpha test economia giurisprudenza kit di preparazione con](#) - Jun 12 2023

web jan 15 2020 questo è il link di amazon per acquistare questo libro amzn to 35qgp4o

*alpha test economia giurisprudenza kit di preparazione con* - Aug 02 2022

web apr 10 2023 read just invest little times to door this on line pronouncement alpha test economia giurisprudenza kit di prepara as capably as evaluation them wherever you

[alpha test economia e giurisprudenza kit di](#) - Mar 09 2023

web compre online alpha test economia giurisprudenza kit di preparazione con contenuto digitale per download e accesso on line de na amazon frete grÁtis em

[alpha test economia giurisprudenza kit di prepara copy](#) - Dec 26 2021

web right here we have countless books alpha test economia giurisprudenza kit di prepara and collections to check out we additionally have the funds for variant types

**alpha test economia giurisprudenza kit di prepara pdf** - Apr 10 2023

web alpha test economia giurisprudenza kit di prepara 1 13 downloaded from uniport edu ng on july 20 2023 by guest alpha test economia giurisprudenza kit di prepara

*alpha test economia giurisprudenza kit di preparazione con* - Apr 29 2022

web alpha test economia giurisprudenza kit di prepara downloaded from rc spectrallabs com by guest alina freddy for a responsible economy mdpi

[alpha test economia giurisprudenza kit di preparazione con](#) - Jul 01 2022

web aug 2 2023 alpha test economia e giurisprudenza kit con alpha test economia giurisprudenza kit di preparazione alpha test economia giurisprudenza kit di

*alpha test economia giurisprudenza kit di preparazione con* - Nov 24 2021

web recognizing the habit ways to get this ebook alpha test economia giurisprudenza kit di prepara is additionally useful you have remained in right site to start getting this info

**schaum s outline of introductory surveying booktopia** - May 18 2023

web booktopia has schaum s outline of introductory surveying schaum s outlines by roy wirshing buy a discounted paperback of schaum s outline of introductory surveying online from australia s leading online bookstore

**schaum s outline of introductory surveying schaum s paperback** - Aug 09 2022

web details schaum s outline of introductory surveying by james r wirshing r h wirshing master introductory surveying with schaum s the high performance study guide it will help you cut study time hone problem solving skills and achieve your personal best on exams students love schaum s outlines because they produce results

[schaum s outline of introductory surveying paperback amazon](#) - Apr 17 2023

web [schaum s outline of introductory surveying wirshing roy wirshing james amazon sg books](#)

**schaums outline introductory surveying orientation sutd edu sg** - Jun 07 2022

web [schaum s outline of introductory surveying schaum s 9780070711242 schaum s outline of introductory surveying](#)

[schaum s outline book series thriftbooks schaums pdf pdf mathematical economics economics 9780070711242 schaum s outline of introductory surveying](#)

**schaum s outline of introductory surveying goodreads** - Jul 20 2023

web jun 1 1985 [schaum s outline of introductory surveying roy wirshing james wirshing 3 82 11 ratings0 reviews with 375 problems fully solved step by step and clear well illustrated coverage of the practices and applications of surveying this powerful study guide can help you master your course with less study time](#)

**introductory surveying powell s books** - Jan 14 2023

web [schaum s outlines give you the information your teachers expect you to know in a handy and succinct format without overwhelming you with unnecessary details you get a complete overview of the subject plus you get plenty of practice exercises to test your skill](#)

[schaum s outline of introductory surveying by wirshing roy](#) - Sep 10 2022

web [master introductory surveying with schaum s the high performance study guide it will help you cut study time hone problem solving skills and achieve your personal best on exams students love schaum s outlines because they produce results](#)

**schaum s outline of introductory surveying schaum s ebooks** - Mar 04 2022

web [schaum s outline of introductory surveying schaum s by wirshing roy wirshing james paperback download schaum s outline of introductory surveying schaum s or read schaum s outline of introductory surveying schaum s online books in pdf epub and mobi format](#)

**schaum s outline of introductory surveying barnes noble** - Feb 15 2023

web [perfect for independent study it gives you full coverage of the entire subject from trigonometry for surveyors through drawing maps with schaum s you know you re getting a quality product and this study guide for beginning courses in](#)

[schaum s outline of theory and problems of introductory surveying](#) - Mar 16 2023

web [schaum s outline of theory and problems of introductory surveying authors james r wirshing roy h wirshing summary with 375 problems fully solved step by step and clear well illustrated coverage of the practices and applications of surveying this powerful study guide can help you master your course with less study time](#)

**schaum s outline of introductory surveying schaum s outline** - Jul 08 2022

web [schaum s outline of introductory surveying schaum s outline series wirshing roy wirshing james amazon in books](#)

[schaum s outline of introductory surveying google books](#) - Aug 21 2023

web mcgraw hill professional jun 22 1985 juvenile nonfiction 360 pages with 375 problems fully solved step by step and clear well illustrated coverage of the practices and applications of

[schaum s outline of introductory surveying mhprofessional com](#) - Sep 22 2023

web jun 1 1985 schaum s outline of introductory surveying trigonometry for surveyors field notes horizontal distances transits leveling angle measurements traverses topographic surveys construction surveys slope staking earthwork horizontal curves with 375 problems fully solved step by step

**schaum s outline of theory and problems of introductory surveying** - Oct 11 2022

web may 26 2023 schaum s outline of theory and problems of introductory surveying by james r wirshing 0 ratings 1 want to read 0 currently reading 0 have read this edition doesn t have a description yet can you add one publish date 1985 publisher mcgraw hill language english pages 360 subjects surveying showing 1 featured edition view all 1

[schaum s outline of introductory surveying mheducation ca](#) - Jun 19 2023

web description with 375 problems fully solved step by step and clear well illustrated coverage of the practices and applications of surveying this powerful study guide can help you master your course with less study time

*epub schaum s outline of introductory surveying schaum* - Apr 05 2022

web aug 21 2021 schaum s outline of introductory surveying schaum s outline series by roy wirshing listen to ebook schaum s outline of introductory surveying schaum s outline series

[schaum s outline of introductory surveying alibris](#) - Nov 12 2022

web buy schaum s outline of introductory surveying by james r wirshing roy h wirshing online at alibris we have new and used copies available in 0 edition starting at shop now

*schaum s outline of introductory surveying schaum s outline* - Dec 13 2022

web abebooks com schaum s outline of introductory surveying schaum s outline series 9780070711242 by wirshing roy wirshing james and a great selection of similar new used and collectible books available now at great prices

**schaum s outline of introductory surveying schaum s** - Oct 23 2023

web jun 1 1985 schaum s outline of introductory surveying schaum s 1st edition with 375 problems fully solved step by step and clear well illustrated coverage of the practices and applications of surveying this powerful study guide can help you master your course with less study time

**download free schaum outline series sutd** - May 06 2022

web schaum s outline of introductory surveying feb 09 2021 collects problems and detailed solutions related to aspects of surveying such as leveling transits angle measurement topographic surveys and slope staking schaum s outline of basic

electrical engineering may 07 2023 a comprehensive guide to electrical engineering