

LAMP VEHICLE			
WHEEL DATA			
A.S.	WHEEL CODE	WHEELS	SURFACE AREA (sq. in.)
11		1.0 20 1/2" W.P.	1.024
12		1.0 20 1/2" W.P. 8 1/2" W.P.	1.024
13		1.0 20 1/2" W.P. 8 1/2" W.P.	1.024
14		1.0 20 1/2" W.P. 8 1/2" W.P.	1.024
15		1.0 20 1/2" W.P.	1.024
TOTAL	5		5.120

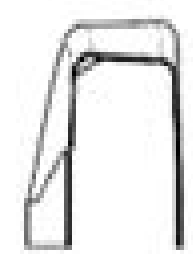
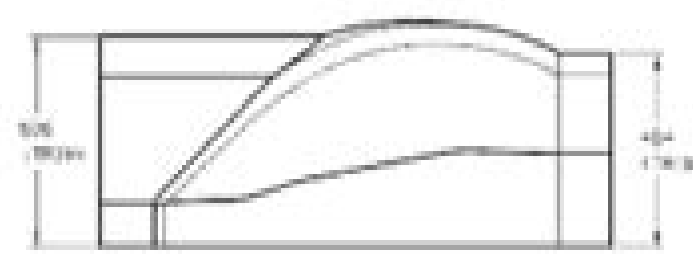
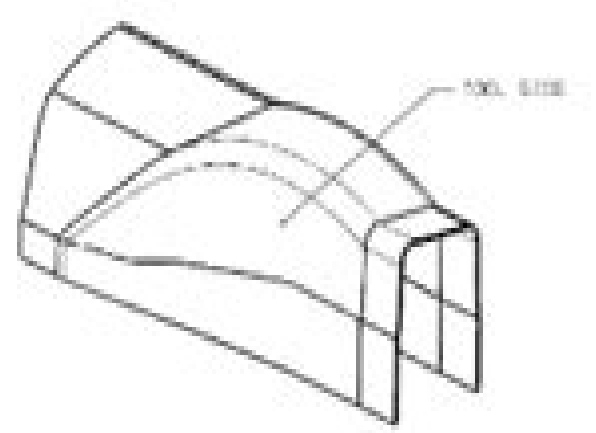

- NOTES:
- PLY 1 CORRESPONDS TO 100L SIZE
 - GROUP 1 LAMP VEHICLE, CODE 1111P
 - WHEELS & WHEEL TYPES MUST BE APPROVED BY:
 - 1. FEDERAL BUREAU OF INVESTIGATION
 - 2. FEDERAL BUREAU OF INVESTIGATION
 - 3. FEDERAL BUREAU OF INVESTIGATION
 - 4. FEDERAL BUREAU OF INVESTIGATION
 - 5. FEDERAL BUREAU OF INVESTIGATION
 - PLY 2, 3, 4, 5 TO BE OVERLAPPED BY MINIMUM 1/2" AT ALL JOINTS
 - OVERLAP JOINTS BETWEEN EACH PLY MUST BE OFFSET 1/2" FROM EACH OTHER AND FROM THE CENTER TO EACH SIDE 1/4" MIN.
 - PLY 2, 3, 4, 5 TO BE OVERLAPPED BY MINIMUM 1/2" AT ALL JOINTS
 - PLY 2, 3, 4, 5 TO BE OVERLAPPED BY MINIMUM 1/2" AT ALL JOINTS
 - PLY 2, 3, 4, 5 TO BE OVERLAPPED BY MINIMUM 1/2" AT ALL JOINTS
 - PLY 2, 3, 4, 5 TO BE OVERLAPPED BY MINIMUM 1/2" AT ALL JOINTS

DESIGNER'S SIGNATURE	DATE	PROJECT NO.	
<i>[Signature]</i>	11/11/11	11111	
DATE DRAWN	11/11/11	BY	11111
11/11/11	11/11/11	11111	11111
APPROVED SIGNATURE OF ENGINEER	DATE	PROJECT NO.	
<i>[Signature]</i>	11/11/11	11111	

Composite Drawing In Engineering

JA Banks



Composite Drawing In Engineering:

Eventually, you will agreed discover a extra experience and carrying out by spending more cash. yet when? do you admit that you require to acquire those all needs once having significantly cash? Why dont you attempt to get something basic in the beginning? Thats something that will guide you to understand even more going on for the globe, experience, some places, later history, amusement, and a lot more?

It is your completely own mature to take effect reviewing habit. among guides you could enjoy now is **Composite Drawing In Engineering** below.

https://py.bijouxmedusa.com/book/scholarship/index.jsp/the_total_money_makeover_a_proven_plan_for_financial_success_wit_h_2_financial_peace_university_dvds_dumping_debt_cash_flow_planning.pdf

Table of Contents Composite Drawing In Engineering

1. Understanding the eBook Composite Drawing In Engineering
 - The Rise of Digital Reading Composite Drawing In Engineering
 - Advantages of eBooks Over Traditional Books
2. Identifying Composite Drawing In Engineering
 - Exploring Different Genres
 - Considering Fiction vs. Non-Fiction
 - Determining Your Reading Goals
3. Choosing the Right eBook Platform
 - Popular eBook Platforms
 - Features to Look for in an Composite Drawing In Engineering
 - User-Friendly Interface
4. Exploring eBook Recommendations from Composite Drawing In Engineering
 - Personalized Recommendations
 - Composite Drawing In Engineering User Reviews and Ratings
 - Composite Drawing In Engineering and Bestseller Lists

5. Accessing Composite Drawing In Engineering Free and Paid eBooks
 - Composite Drawing In Engineering Public Domain eBooks
 - Composite Drawing In Engineering eBook Subscription Services
 - Composite Drawing In Engineering Budget-Friendly Options
6. Navigating Composite Drawing In Engineering eBook Formats
 - ePub, PDF, MOBI, and More
 - Composite Drawing In Engineering Compatibility with Devices
 - Composite Drawing In Engineering Enhanced eBook Features
7. Enhancing Your Reading Experience
 - Adjustable Fonts and Text Sizes of Composite Drawing In Engineering
 - Highlighting and Note-Taking Composite Drawing In Engineering
 - Interactive Elements Composite Drawing In Engineering
8. Staying Engaged with Composite Drawing In Engineering
 - Joining Online Reading Communities
 - Participating in Virtual Book Clubs
 - Following Authors and Publishers Composite Drawing In Engineering
9. Balancing eBooks and Physical Books Composite Drawing In Engineering
 - Benefits of a Digital Library
 - Creating a Diverse Reading Collection Composite Drawing In Engineering
10. Overcoming Reading Challenges
 - Dealing with Digital Eye Strain
 - Minimizing Distractions
 - Managing Screen Time
11. Cultivating a Reading Routine Composite Drawing In Engineering
 - Setting Reading Goals Composite Drawing In Engineering
 - Carving Out Dedicated Reading Time
12. Sourcing Reliable Information of Composite Drawing In Engineering
 - Fact-Checking eBook Content of Composite Drawing In Engineering
 - Distinguishing Credible Sources
13. Promoting Lifelong Learning

- Utilizing eBooks for Skill Development
 - Exploring Educational eBooks
14. Embracing eBook Trends
- Integration of Multimedia Elements
 - Interactive and Gamified eBooks

Composite Drawing In Engineering Introduction

In the digital age, access to information has become easier than ever before. The ability to download Composite Drawing In Engineering has revolutionized the way we consume written content. Whether you are a student looking for course material, an avid reader searching for your next favorite book, or a professional seeking research papers, the option to download Composite Drawing In Engineering has opened up a world of possibilities. Downloading Composite Drawing In Engineering provides numerous advantages over physical copies of books and documents. Firstly, it is incredibly convenient. Gone are the days of carrying around heavy textbooks or bulky folders filled with papers. With the click of a button, you can gain immediate access to valuable resources on any device. This convenience allows for efficient studying, researching, and reading on the go. Moreover, the cost-effective nature of downloading Composite Drawing In Engineering has democratized knowledge. Traditional books and academic journals can be expensive, making it difficult for individuals with limited financial resources to access information. By offering free PDF downloads, publishers and authors are enabling a wider audience to benefit from their work. This inclusivity promotes equal opportunities for learning and personal growth. There are numerous websites and platforms where individuals can download Composite Drawing In Engineering. These websites range from academic databases offering research papers and journals to online libraries with an expansive collection of books from various genres. Many authors and publishers also upload their work to specific websites, granting readers access to their content without any charge. These platforms not only provide access to existing literature but also serve as an excellent platform for undiscovered authors to share their work with the world. However, it is essential to be cautious while downloading Composite Drawing In Engineering. Some websites may offer pirated or illegally obtained copies of copyrighted material. Engaging in such activities not only violates copyright laws but also undermines the efforts of authors, publishers, and researchers. To ensure ethical downloading, it is advisable to utilize reputable websites that prioritize the legal distribution of content. When downloading Composite Drawing In Engineering, users should also consider the potential security risks associated with online platforms. Malicious actors may exploit vulnerabilities in unprotected websites to distribute malware or steal personal information. To protect themselves, individuals should ensure their devices have reliable antivirus software installed and validate the legitimacy of the websites they are downloading from. In conclusion, the ability

to download Composite Drawing In Engineering has transformed the way we access information. With the convenience, cost-effectiveness, and accessibility it offers, free PDF downloads have become a popular choice for students, researchers, and book lovers worldwide. However, it is crucial to engage in ethical downloading practices and prioritize personal security when utilizing online platforms. By doing so, individuals can make the most of the vast array of free PDF resources available and embark on a journey of continuous learning and intellectual growth.

FAQs About Composite Drawing In Engineering Books

How do I know which eBook platform is the best for me? Finding the best eBook platform depends on your reading preferences and device compatibility. Research different platforms, read user reviews, and explore their features before making a choice. Are free eBooks of good quality? Yes, many reputable platforms offer high-quality free eBooks, including classics and public domain works. However, make sure to verify the source to ensure the eBook credibility. Can I read eBooks without an eReader? Absolutely! Most eBook platforms offer webbased readers or mobile apps that allow you to read eBooks on your computer, tablet, or smartphone. How do I avoid digital eye strain while reading eBooks? To prevent digital eye strain, take regular breaks, adjust the font size and background color, and ensure proper lighting while reading eBooks. What the advantage of interactive eBooks? Interactive eBooks incorporate multimedia elements, quizzes, and activities, enhancing the reader engagement and providing a more immersive learning experience. Composite Drawing In Engineering is one of the best book in our library for free trial. We provide copy of Composite Drawing In Engineering in digital format, so the resources that you find are reliable. There are also many Ebooks of related with Composite Drawing In Engineering. Where to download Composite Drawing In Engineering online for free? Are you looking for Composite Drawing In Engineering PDF? This is definitely going to save you time and cash in something you should think about. If you trying to find then search around for online. Without a doubt there are numerous these available and many of them have the freedom. However without doubt you receive whatever you purchase. An alternate way to get ideas is always to check another Composite Drawing In Engineering. This method for see exactly what may be included and adopt these ideas to your book. This site will almost certainly help you save time and effort, money and stress. If you are looking for free books then you really should consider finding to assist you try this. Several of Composite Drawing In Engineering are for sale to free while some are payable. If you arent sure if the books you would like to download works with for usage along with your computer, it is possible to download free trials. The free guides make it easy for someone to free access online library for download books to your device. You can get free download on free trial for lots of books categories. Our library is the biggest of these that have literally hundreds of thousands of different products categories represented. You will also see that there are

specific sites catered to different product types or categories, brands or niches related with Composite Drawing In Engineering. So depending on what exactly you are searching, you will be able to choose e books to suit your own need. Need to access completely for Campbell Biology Seventh Edition book? Access Ebook without any digging. And by having access to our ebook online or by storing it on your computer, you have convenient answers with Composite Drawing In Engineering To get started finding Composite Drawing In Engineering, you are right to find our website which has a comprehensive collection of books online. Our library is the biggest of these that have literally hundreds of thousands of different products represented. You will also see that there are specific sites catered to different categories or niches related with Composite Drawing In Engineering So depending on what exactly you are searching, you will be able to choose ebook to suit your own need. Thank you for reading Composite Drawing In Engineering. Maybe you have knowledge that, people have search numerous times for their favorite readings like this Composite Drawing In Engineering, but end up in harmful downloads. Rather than reading a good book with a cup of coffee in the afternoon, instead they juggled with some harmful bugs inside their laptop. Composite Drawing In Engineering is available in our book collection an online access to it is set as public so you can download it instantly. Our digital library spans in multiple locations, allowing you to get the most less latency time to download any of our books like this one. Merely said, Composite Drawing In Engineering is universally compatible with any devices to read.

Find Composite Drawing In Engineering :

the total money makeover a proven plan for financial success with 2 financial peace university dvds dumping debt cash flow planning

the victorian frame of mind 1830 1870 yale paperbound y 99

the philosophy of poverty

theory and practice of family therapy and counseling

the nature of order an essay on the art of building and the nature of the universe book 4 the luminous ground center for environmental structure vol 12

the politics of freedom

the spirit of python exposing satans plan to squeeze life out you kindle edition jentezen franklin

the quest for serenity in world religions 1st published in india

theoretical mechanics

theory and problems of mechanical vibrations including 225 solved problems completely solved in detail schaums outline series

the social environment a primer on world civics 13th edition 13th edition

the new first aid in english 2nd edition

the spiritual flower garden 101 devotional poems of gerhard tersteegen a protestant mystic 1697 1769 ad translated

the why cafe john p strelecky

therapeutic modalities in rehabilitation 3rd edition

Composite Drawing In Engineering :

aux confins de la terre une vie en terre de feu f copy - May 25 2022

web de la terre aux confins de l univers aux confins des prévôtés d arlon de bastogne et de la terre de neufchateau les seigneuries du chêne d ebly et du monceau deyse une vie de prière

[aux confins de la terre une vie en terre de feu cultura](#) - Nov 30 2022

web aux confins de la terre une vie en terre de feu par esteban lucas bridges aux éditions nevicata découvrez la fabuleuse et incroyable histoire de lucas bridge né et élevé au milieu d un peuple indien aujourd hui disparu un immense enthousiasme accueillit tout le catalogue tout le catalogue univers enfant

aux confins de la terre une vie en terre de feu google books - Aug 08 2023

web découvrez la fabuleuse et incroyable histoire de lucas bridge né et élevé au milieu d un peuple indien aujourd hui disparu un immense enthousiasme accueillit la parution en 1948

[feu de terre traduction en anglais reverso context](#) - Feb 19 2022

web traductions en contexte de feu de terre en français anglais avec reverso context terre de feu traduction context

correcteur synonymes conjugaison conjugaison documents dictionnaire dictionnaire collaboratif grammaire expressio reverso corporate télécharger pour windows connexion

[aux confins de la terre une vie en terre de feu amazon fr](#) - May 05 2023

web noté 5 retrouvez aux confins de la terre une vie en terre de feu et des millions de livres en stock sur amazon fr achetez neuf ou d occasion

[aux confins de la terre une vie en terre de feu f wef tamu](#) - Oct 30 2022

web aux confins de la terre une vie en terre de feu f 1 aux confins de la terre une vie en terre de feu f this is likewise one of the factors by obtaining the soft documents of this aux confins de la terre une vie en terre de feu f by online you might not require more times to spend to go to the books commencement as skillfully as search for them

aux confins de la terre une vie en terre de feu f 2023 - Sep 28 2022

web aux confins de la terre une vie en terre de feu f this is likewise one of the factors by obtaining the soft documents of this aux confins de la terre une vie en terre de feu f by online you might not require more grow old to spend to go to the books introduction as capably as search for them

aux confins de la terre une vie en terre de feu google books - Jun 06 2023

web la fabuleuse et incroyable histoire de lucas bridge né et élevé au milieu d un peuple indien aujourd hui disparu la première édition en 1948 de aux confins de la terre la m

aux confins de la terre une vie en terre de feu f pdf - Sep 09 2023

web it is your totally own time to perform reviewing habit in the midst of guides you could enjoy now is aux confins de la terre une vie en terre de feu f below aux confins de la terre e lucas bridges 2020 12 03 découvrez la fabuleuse et incroyable histoire de lucas bridge né et élevé au milieu d un peuple indien aujourd hui disparu

aux confins de la terre une vie en terre de feu fnac - Oct 10 2023

web jun 4 2020 aux confins de la terre une vie en terre de feu esteban lucas bridges nevicata des milliers de livres avec la livraison chez vous en 1 jour ou en magasin avec 5 de réduction ou téléchargez la version ebook

définition aux confins de la terre dictionnaire français reverso - Jun 25 2022

web n pavé plat en terre cuite en pierre voir tous les résultats traduction aux confins de la terre dans le dictionnaire français français de reverso voir aussi confiné confusion confiant confiner conjugaison expressions idiomatiques

aux confins de la terre une vie en terre de feu f unifi like - Aug 28 2022

web aux confins de la terre une vie en terre de feu f receptions of antiquity liber amicorum proceedings of the royal society of canada anthropologica mes souvenirs de 75 ans premier volume l histoire de l amerique la pensŽe europŽenne au xviiiē si cle studies on psalms la terre d un clic du bon usage des satellites

[aux confins de la terre une vie en terre de feu 1874 1910](#) - Jul 07 2023

web retrouvez aux confins de la terre une vie en terre de feu 1874 1910 et des millions de livres en stock sur amazon fr achetez neuf ou d occasion

aux confins de la terre une vie en terre de feu format kindle - Jan 01 2023

web achetez et téléchargez ebook aux confins de la terre une vie en terre de feu boutique kindle américaines amazon fr

aux confins de la terre une vie en terre de feu cultura - Mar 03 2023

web aux confins de la terre une vie en terre de feu aux éditions nevicata la fabuleuse et incroyable histoire de lucas bridge né et élevé au milieu d un peuple indien aujourd hui disparu la première édition en 1948 de aux confins de tout le catalogue tout le catalogue livre

terre de feu wikipédia - Mar 23 2022

web la terre de feu vue depuis l'espace situé à la confluence des océans atlantique à l'est et pacifique à l'ouest l'archipel de la terre de feu est limité au nord par le détroit de magellan qui le sépare de la patagonie au sud le passage de drake sépare les îles du continent antarctique

aux confins de la terre une vie en terre de feu 1874 1910 - Feb 02 2023

web aux confins de la terre une vie en terre de feu 1874 1910 aux éditions nevicata la parution en 1948 d'aux confins de la terre la merveilleuse chronique de e lucas bridges sur la terre de feu fut accueillie avec un immense enthousiasme et

aux confins de la terre une vie en terre de feu 1874 1910 - Apr 04 2023

web may 27 2010 aux confins de la terre une vie en terre de feu 1874 1910 de e lucas bridges Éditeur nevicata livraison gratuite à 0 01 dès 35 d'achat librairie decitre votre prochain livre est là

définition la terre de feu dictionnaire français reverso - Jul 27 2022

web 1 levée de terre horizontale souvent soutenue par des murs 2 bande qui sépare les chaussées d'une voie à grande circulation être terré v être caché sous terre tire terre nm inv technologie dans les carrières pioche servant à retirer la terre autour de la roche ventre à terre adv à grande vitesse

terre de feu vikidia l'encyclopédie des 8 13 ans - Apr 23 2022

web carte de la terre de feu la terre de feu est le nom donné à un archipel situé à l'extrême sud de l'amérique du sud elle est partagée entre le chili et l'argentine elle comprend également plusieurs îlots sa superficie est de 73 753 km²

on becoming baby wise giving your infant the gift of - Oct 03 2023

web on becoming babywise giving you and your infant the gift of nighttime sleep baby book for new parents first time mom book sleep training for babies pediatrician

on becoming baby wise giving your infant the gift of nighttime - Apr 16 2022

on becoming babywise updated and expanded - Nov 23 2022

web dec 1 2017 on becoming babywise giving your infant the gift of nighttime sleep bucknam m dr robert 9781932740172 books amazon ca

on becoming babywise giving your infant the gift of ni - Aug 21 2022

web feb 1 2012 on becoming baby wise giving your infant the gift of nighttime sleep kindle edition 1 taking care of baby and mom 2 a timeline of what to expect and when 3

on becoming babywise giving your infant the gift of nighttime - Mar 28 2023

web jan 1 2019 on becoming babywise giving your infant the gift of nighttime sleep interactive support on apple books on becoming on becoming babywise giving

on becoming babywise giving you and your infant the gift of - Sep 02 2023

web on becoming babywise giving your infant the gift of nighttime sleep new edition bucknam m d robert ezzo m a gary amazon sg books

on becoming babywise giving your infant the gift of nighttime - Dec 25 2022

web oct 1 2020 on becoming babywise giving your infant the gift of nighttime sleep robert bucknam gary ezzo 4 05 471 ratings25 reviews distinguished pediatrician dr

on becoming babywise giving your infant the gift of - Feb 12 2022

on becoming babywise bucknam m d robert ezzo - Feb 24 2023

web dec 11 2018 on becoming babywise giving your infant the gift of nighttime sleep bucknam md 9781932740509 books amazon ca

on becoming babywise giving your infant the gift of nighttime - May 18 2022

on becoming babywise giving your infant the gift of ni - Jun 30 2023

web dec 1 2020 on becoming babywise giving your infant the gift of nighttime sleep new edition on becoming kindle edition by bucknam m d robert ezzo m a

on becoming baby wise wikipedia - Jan 26 2023

web for over 25 years on becoming babywise has been the de facto newborn parenting manual for naturally synchronizing your baby s feeding time waketime and nighttime

on becoming babywise giving your infant the gift of nighttime - Aug 01 2023

web on becoming babywise giving your infant the gift of nighttime sleep interactive support gary ezzo robert bucknam md 3 67 15 477 ratings2 273 reviews want to read

on becoming baby wise giving your infant the gift of nighttime - Jan 14 2022

on becoming babywise giving your infant the gift of - Jun 18 2022

on becoming babywise giving your infant the gift of ni - May 30 2023

web on becoming babywise giving your infant the gift of nighttime sleep bucknam m dr robert amazon sg books

on becoming babywise giving your infant the gift of booktopia - Mar 16 2022

on becoming babywise giving your infant the gift of nighttime - Oct 23 2022

web there is a newer edition of this item on becoming babywise giving your infant the gift of nighttime sleep new edition 39 55 3 954 usually dispatched within 6 to 7 days

on becoming babywise giving your infant the gift of - Apr 28 2023

web on becoming baby wise giving your infant the gift of nighttime sleep is a christianity based infant management book written by gary ezzo and pediatrician robert bucknam

on becoming babywise giving your infant the gift of nighttime - Sep 21 2022

web apr 1 2017 on becoming babywise giving your infant the gift of nighttime sleep by gary ezzo 9781932740134 booktopia books non fiction family health

on becoming baby wise giving your infant the gift - Jul 20 2022

succeed in b1 preliminary google books - Apr 17 2023

web feb 22 2022 succeed in nocn proficient level c2 new 2022 edition 12 1 practice tests key features 13 complete practice tests 12 in the printed book 1 online

andrew betsis author of succeed in ielts academic 6 - Feb 15 2023

web succeed in ielts general student s book andrew betsis linda maria windsor 1781641773 toronto public library andrew betsis linda maria windsor series

books by andrew betsis author of succeed in ielts academic - Mar 16 2023

web dec 9 2022 availability 1 succeed in ielts life skills ce fr a1 speaking listening 2015 global elt in english 1781642761 9781781642764 aaaa borrow listen

succeed in movers andrew betsis pdf scribd - Feb 03 2022

web sep 18 2023 unions keep up their hardball tactics in contract disputes from detroit to hollywood organized labor leaders are holding firm in their efforts to gain more pay and

succeed in ielts 9 practice tests google books - Aug 29 2021

succeed in ielts life skills by andrew betsis open library - Dec 13 2022

web succeed in cambridge fce 10 practice tests teacher s book andrew betsis garnet education 2009 english language 207 pages complete practice tests for the revised

succeed in ielts general student s book betsis andrew - Nov 12 2022

web succeed in b1 preliminary 8 complete practice tests for the b1 preliminary revised exam 2020 authors andrew betsis

lawrence mamas publisher global elt 2019 isbn

succeed in cambridge ket teacher s book with 6 practice tests - Jul 28 2021

succeed in ecpe michigan language assessment - Jun 19 2023

web sort by previous 1 2 3 next note these are all the books on goodreads for this author to add more books click here

andrew betsis has 76 books on goodreads with 909

andrew betsis new succeed - Sep 29 2021

web save save succeed in starters andrew betsis with answer key for later 100 100 found this document useful mark this document as devil in the grove thurgood

succeed in the new cambridge proficiency cpe amazon co uk - Jul 08 2022

web this is the self study edition of the series that includes the student s book and a self study guide these consist of a writing supplement with model compositions as well as a

succeed in cambridge fce 10 practice tests teacher s book - Sep 10 2022

web succeed in cambridge fce 10 practice tests student book cds andrew betsis garnet education 2009 educational tests and measurements 207 pages 0 reviews

succeed in cambridge fce 10 practice tests student book cds - Jun 07 2022

web download the ebook succeed in ielts speaking and vocabulary student s book andrew betsis in pdf or epub format and read it directly on your mobile phone

unions stick with hardball tactics like strikes the new york - Oct 31 2021

web jan 1 2010 this is the overprinted edition designed specifically for teachers it covers 6 complete cambridge english key ket practice tests that help you familiarise with the

succeed in starters andrew betsis with answer key pdf scribd - Jun 26 2021

succeed in b1 preliminary google books - Aug 09 2022

web bu sezon başakşehir avrupa süper lig 9 galibiyet 3 beraberlik atılan gol 25 yenilen gol 4 12 sep 2022 18 01 25

read pdf new succeed in toEIC online book of donmon teith - May 18 2023

web andrew betsis is the author of succeed in ielts academic 6 practice tests 3 79 avg rating 57 ratings 3 reviews the vocabulary files english usage

succeed in ielts academic andrew betsis elt - Aug 21 2023

web download or read book new succeed in toEIC written by andrew betsis and published by this book was released on 2018

with total page pages available in pdf epub and

[bu sezon başakşehir avrupa süper lig 9 galibiyet twitter](#) - May 06 2022

web succeed in movers andrew betsis free ebook download as pdf file pdf or read book online for free tests movers 2018 tests movers 2018 open navigation menu

betsis andrew mamas lawrence new succeed in ielts - Oct 11 2022

web jan 1 2012 buy succeed in the new cambridge proficiency cpe student s book with 8 practice tests by betsis andrew isbn 9781781640104 from amazon s book store

[succeed in ielts speaking and vocabulary student s book](#) - Mar 04 2022

web 1 day ago speaking on afl 360 plus brereton opined that yze ultimately won the job due to x factor and tactical acumen but he urged mcqualter to stay on board at the tigers

[new book out now succeed in nocn andrew betsis elt](#) - Jan 14 2023

web oct 17 2018 betsis andrew mamas lawrence new succeed in ielts academic 3 downloadable practice tests with audio rar file size 52 84 mb contains archive pdf

[succeed in ielts 9 practice tests andrew betsis lawrence](#) - Apr 05 2022

web sep 22 2023 alastair grant ap l ondon astrazeneca said friday an experimental drug tamped down the progression of a certain type of breast cancer in a phase 3 trial a

astrazeneca daiichi breast cancer treatment succeeds in trial - Jan 02 2022

web title andrew betsis new succeed author discourse reconstructingjudaism org 2023 08 27 23 37 45 subject andrew betsis new succeed keywords

afl 2023 richmond appoint new senior coach adem yze beats - Dec 01 2021

web andrew betsis lawrence mamas global elt 2011 juvenile nonfiction 208 pages this item consists of 9 complete cambridge ielts practice tests that help you familiarise

andrew betsis elt - Jul 20 2023

web succeed in b1 preliminary 8 complete practice tests for the b1 preliminary revised exam 2020 overprinted edition with answers andrew betsis lawrence mamas global elt