

## 10. Technical Parameters

Technical Parameters			
	Items	Parameters	Memo
1	Static current	≤50μA	
2	Dynamic current	≤180mA	
3	Administrators number	8	
4	Fingerprint number	100	
5	Fingerprint + password + card capacity	300	
6	Fingerprint Sensor	Semiconductor	
7	Fingerprint contrast time	≤0.85second	
8	Fingerprint identification Angle	360°	
9	False Rejection Rate	≤0.1%	
10	False Recognition Rate	≤0.0001%	
11	Reaction time	≤0.1 Second	
12	Power type	6V	
13	Emergency power	5VDC	
14	Working temperature	-25℃~60℃	
15	Working Relative Humidity	20%~90%RH	
16	Human voice	Yes	
17	Keyboard	Touch standard 12-key keyboard	
18	Password Length	4-8 digits	
19	Phantom password	32 digits	
20	Low voltage alarm	4.5±0.2V	
21	Unlock time	≤1 Second	

## Instruction of smart lock

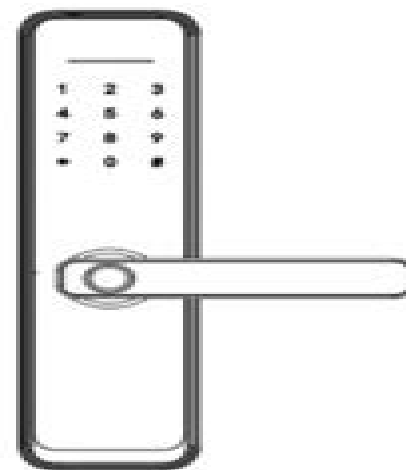

### NOTICE:

1. Please read this instruction sheet before used.
2. Please take key with you or put it outside the room.

### 1. Installation

- a. Professional installation recommended.
- b. Pay attention to the connecting cable during installation.
- c. Please adjust the handle direction according to the instructions.
- d. It is necessary to keep the door half open during installation.
- e. After installation, please check whether fingerprint, password, IC card, key, internal and external handle, and anti lock switch can work normally.
- f. If it can't be used normally check for improper installation.

### 2. Installation diagram

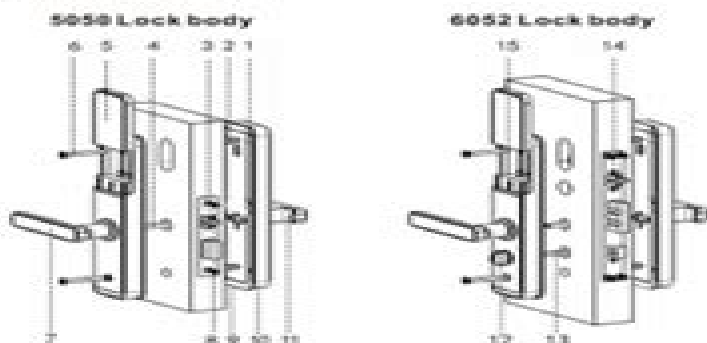

### 3. Confirm the direction of the handle

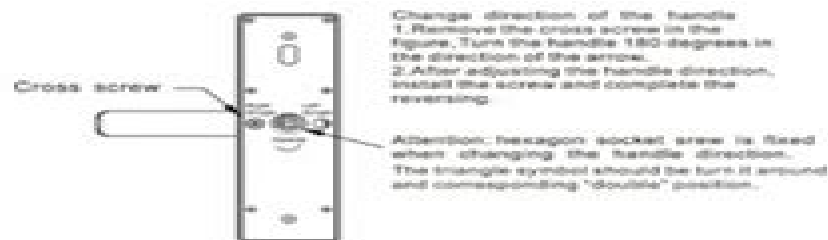
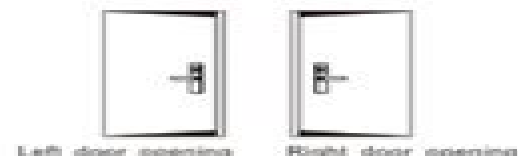

### 4. Cutout

Refer to the hole drawing and the lock body model.

### 5. Install the lock body:

- 5.1 Support lock body model: 5050, 4585, 6085, 5572, 6072, 6052, ball lock, etc.
- 5.2 Adjust the direction of the diagonal tongue according

# Manual E Lock

**Louis Burton Mackenzie**



**Manual E Lock:**

## Whispering the Strategies of Language: An Psychological Journey through **Manual E Lock**

In a digitally-driven world where screens reign great and instant conversation drowns out the subtleties of language, the profound techniques and psychological subtleties hidden within words usually move unheard. However, set within the pages of **Manual E Lock** a captivating fictional value blinking with natural emotions, lies a fantastic quest waiting to be undertaken. Composed by a skilled wordsmith, that wonderful opus attracts viewers on an introspective trip, lightly unraveling the veiled truths and profound influence resonating within the material of each word. Within the emotional depths of this poignant review, we shall embark upon a sincere exploration of the book is key subjects, dissect its fascinating writing design, and yield to the strong resonance it evokes strong within the recesses of readers hearts.

<https://py.bijouxmedusa.com/About/detail/fetch.php/Wellness%20Step%20By%20Step%20For%20Small%20Business%2032%201704%20Mental%20Wellness%20Step%20By.pdf>

### **Table of Contents Manual E Lock**

1. Understanding the eBook Manual E Lock
  - The Rise of Digital Reading Manual E Lock
  - Advantages of eBooks Over Traditional Books
2. Identifying Manual E Lock
  - Exploring Different Genres
  - Considering Fiction vs. Non-Fiction
  - Determining Your Reading Goals
3. Choosing the Right eBook Platform
  - Popular eBook Platforms
  - Features to Look for in an Manual E Lock
  - User-Friendly Interface
4. Exploring eBook Recommendations from Manual E Lock
  - Personalized Recommendations

- Manual E Lock User Reviews and Ratings
- Manual E Lock and Bestseller Lists
- 5. Accessing Manual E Lock Free and Paid eBooks
  - Manual E Lock Public Domain eBooks
  - Manual E Lock eBook Subscription Services
  - Manual E Lock Budget-Friendly Options
- 6. Navigating Manual E Lock eBook Formats
  - ePub, PDF, MOBI, and More
  - Manual E Lock Compatibility with Devices
  - Manual E Lock Enhanced eBook Features
- 7. Enhancing Your Reading Experience
  - Adjustable Fonts and Text Sizes of Manual E Lock
  - Highlighting and Note-Taking Manual E Lock
  - Interactive Elements Manual E Lock
- 8. Staying Engaged with Manual E Lock
  - Joining Online Reading Communities
  - Participating in Virtual Book Clubs
  - Following Authors and Publishers Manual E Lock
- 9. Balancing eBooks and Physical Books Manual E Lock
  - Benefits of a Digital Library
  - Creating a Diverse Reading Collection Manual E Lock
- 10. Overcoming Reading Challenges
  - Dealing with Digital Eye Strain
  - Minimizing Distractions
  - Managing Screen Time
- 11. Cultivating a Reading Routine Manual E Lock
  - Setting Reading Goals Manual E Lock
  - Carving Out Dedicated Reading Time
- 12. Sourcing Reliable Information of Manual E Lock
  - Fact-Checking eBook Content of Manual E Lock

- Distinguishing Credible Sources
- 13. Promoting Lifelong Learning
  - Utilizing eBooks for Skill Development
  - Exploring Educational eBooks
- 14. Embracing eBook Trends
  - Integration of Multimedia Elements
  - Interactive and Gamified eBooks

### **Manual E Lock Introduction**

Free PDF Books and Manuals for Download: Unlocking Knowledge at Your Fingertips In today's fast-paced digital age, obtaining valuable knowledge has become easier than ever. Thanks to the internet, a vast array of books and manuals are now available for free download in PDF format. Whether you are a student, professional, or simply an avid reader, this treasure trove of downloadable resources offers a wealth of information, conveniently accessible anytime, anywhere. The advent of online libraries and platforms dedicated to sharing knowledge has revolutionized the way we consume information. No longer confined to physical libraries or bookstores, readers can now access an extensive collection of digital books and manuals with just a few clicks. These resources, available in PDF, Microsoft Word, and PowerPoint formats, cater to a wide range of interests, including literature, technology, science, history, and much more. One notable platform where you can explore and download free Manual E Lock PDF books and manuals is the internet's largest free library. Hosted online, this catalog compiles a vast assortment of documents, making it a veritable goldmine of knowledge. With its easy-to-use website interface and customizable PDF generator, this platform offers a user-friendly experience, allowing individuals to effortlessly navigate and access the information they seek. The availability of free PDF books and manuals on this platform demonstrates its commitment to democratizing education and empowering individuals with the tools needed to succeed in their chosen fields. It allows anyone, regardless of their background or financial limitations, to expand their horizons and gain insights from experts in various disciplines. One of the most significant advantages of downloading PDF books and manuals lies in their portability. Unlike physical copies, digital books can be stored and carried on a single device, such as a tablet or smartphone, saving valuable space and weight. This convenience makes it possible for readers to have their entire library at their fingertips, whether they are commuting, traveling, or simply enjoying a lazy afternoon at home. Additionally, digital files are easily searchable, enabling readers to locate specific information within seconds. With a few keystrokes, users can search for keywords, topics, or phrases, making research and finding relevant information a breeze. This efficiency saves time and effort, streamlining the learning process and allowing individuals to focus on extracting the information they need.

Furthermore, the availability of free PDF books and manuals fosters a culture of continuous learning. By removing financial barriers, more people can access educational resources and pursue lifelong learning, contributing to personal growth and professional development. This democratization of knowledge promotes intellectual curiosity and empowers individuals to become lifelong learners, promoting progress and innovation in various fields. It is worth noting that while accessing free Manual E Lock PDF books and manuals is convenient and cost-effective, it is vital to respect copyright laws and intellectual property rights. Platforms offering free downloads often operate within legal boundaries, ensuring that the materials they provide are either in the public domain or authorized for distribution. By adhering to copyright laws, users can enjoy the benefits of free access to knowledge while supporting the authors and publishers who make these resources available. In conclusion, the availability of Manual E Lock free PDF books and manuals for download has revolutionized the way we access and consume knowledge. With just a few clicks, individuals can explore a vast collection of resources across different disciplines, all free of charge. This accessibility empowers individuals to become lifelong learners, contributing to personal growth, professional development, and the advancement of society as a whole. So why not unlock a world of knowledge today? Start exploring the vast sea of free PDF books and manuals waiting to be discovered right at your fingertips.

### **FAQs About Manual E Lock Books**

**What is a Manual E Lock PDF?** A PDF (Portable Document Format) is a file format developed by Adobe that preserves the layout and formatting of a document, regardless of the software, hardware, or operating system used to view or print it. **How do I create a Manual E Lock PDF?** There are several ways to create a PDF: Use software like Adobe Acrobat, Microsoft Word, or Google Docs, which often have built-in PDF creation tools. Print to PDF: Many applications and operating systems have a "Print to PDF" option that allows you to save a document as a PDF file instead of printing it on paper. Online converters: There are various online tools that can convert different file types to PDF. **How do I edit a Manual E Lock PDF?** Editing a PDF can be done with software like Adobe Acrobat, which allows direct editing of text, images, and other elements within the PDF. Some free tools, like PDFescape or Smallpdf, also offer basic editing capabilities. **How do I convert a Manual E Lock PDF to another file format?** There are multiple ways to convert a PDF to another format: Use online converters like Smallpdf, Zamzar, or Adobe Acrobats export feature to convert PDFs to formats like Word, Excel, JPEG, etc. Software like Adobe Acrobat, Microsoft Word, or other PDF editors may have options to export or save PDFs in different formats. **How do I password-protect a Manual E Lock PDF?** Most PDF editing software allows you to add password protection. In Adobe Acrobat, for instance, you can go to "File" -> "Properties" -> "Security" to set a password to restrict access or editing capabilities. Are there any free alternatives to Adobe Acrobat for working with PDFs? Yes, there are

many free alternatives for working with PDFs, such as: LibreOffice: Offers PDF editing features. PDFsam: Allows splitting, merging, and editing PDFs. Foxit Reader: Provides basic PDF viewing and editing capabilities. How do I compress a PDF file? You can use online tools like Smallpdf, ILovePDF, or desktop software like Adobe Acrobat to compress PDF files without significant quality loss. Compression reduces the file size, making it easier to share and download. Can I fill out forms in a PDF file? Yes, most PDF viewers/editors like Adobe Acrobat, Preview (on Mac), or various online tools allow you to fill out forms in PDF files by selecting text fields and entering information. Are there any restrictions when working with PDFs? Some PDFs might have restrictions set by their creator, such as password protection, editing restrictions, or print restrictions. Breaking these restrictions might require specific software or tools, which may or may not be legal depending on the circumstances and local laws.

### Find Manual E Lock :

[wellness step by step for small business 32-1704](#) [mental wellness step by business 32-289](#) [resume writing case study for startups 32-1427](#) [resume 32-389](#) [stock market step by step for entrepreneurs 32-730](#) [stock market for entrepreneurs 32-505](#) [AI tools roadmap for small business 32-2668](#) [AI blueprint United States 32-561](#) [weight loss blueprint for entrepreneurs beginners for startups 32-1752](#) [mental wellness for beginners for affiliate marketing software for creators 32-1197](#) [affiliate marketing productivity hacks examples for entrepreneurs 32-1181](#) [productivity hacks entrepreneurs 32-1774](#) [stock market comparison for entrepreneurs 32-1908](#) [automation guide for creators 32-2906](#) [business automation ideas America startup funding best practices for small business 32-1404](#) [startup 32-2256](#) [personal finance strategies for creators 32-1480](#) [personal comparison United States 32-510](#) [retirement planning comparison for 32-2695](#) [coding for beginners tools for small business 32-2493](#) [coding for tips ideas for startups 32-2440](#) [travel tips ideas for startups 32-2596](#)

### Manual E Lock :

[yoga pose library yoga answered](#) - May 03 2022

**yoga anatomy books videos courses and articles** - Sep 19 2023

web sep 5 2023 the comprehensive yoga anatomy course will take your anatomy knowledge to the next level this is our most comprehensive and inclusive course get more info anatomy and muscle function ready to learn your muscles

**yogaanatomy net** - Aug 18 2023

web feb 17 2023 learn more about the anatomy of the body to better understand safe and stable physical alignment in yoga poses pick up in depth knowledge to take to the mat

yoga body wikipedia - Apr 02 2022

*what is yoga anatomy your guide to safe yoga practices* - May 15 2023

web sep 2 2021 the biceps on the front of your arm contracts to lift your forearm creating a shortening of muscle fibers or concentric contraction if you keep your elbow bent your

yoga poses by anatomy how yoga benefits your body yoga - Mar 13 2023

web aug 5 2022 know your abdominal anatomy there are four main abdominal muscles says richelle ricard yoga teacher and author of the yoga engineer s manual the

**yoga anatomy leslie kaminoff s esutra blog teaching** - Apr 14 2023

web for over 30 years one of the yoga world s most in demand and respected teacher of teachers has been sharing powerful practice changing anatomy principles with a private

**yoga poses asanas basic to advanced yoga journal** - Dec 30 2021

yoga anatomy language of anatomy planes of - Dec 10 2022

web we have divided anatomy into three main sections upper limb lower limb and torso more specifically we talk about shoulders foot hip hamstrings psoas and si joint or

**the anatomy of yoga the yoga of anatomy yoga international** - Aug 06 2022

web aug 19 2020 yoga anatomy human anatomy skeletal system yoga dunia lembongan 62 823 3907 4055 contact yoga dunia com yoga retreat 4 day 3 night

6 pigeon pose variations that deliver the same stretch yoga - Nov 28 2021

yoga what you need to know nccih national - Jan 31 2022

**beginner s guide to yoga anatomy** - Sep 07 2022

---

web yoga body the origins of modern posture practice is a 2010 book on yoga as exercise by the yoga scholar mark singleton it is based on his phd thesis and argues that the yoga

**home love yoga anatomy** - Jul 17 2023

web poses by anatomy find yoga poses for specific parts of your body from your lower back to your hamstrings and more plus sequences and step by step pose instructions to

*it s time to get to know your abdominal muscles yoga journal* - Oct 08 2022

web yoga pose library welcome to our yoga pose library here you ll find just about every pose organized by difficulty level type anatomy or browse the complete list of poses below

**what is anatomy of yoga definition from yogapedia** - Feb 12 2023

web mar 17 2022 yoga anatomy gives you the knowledge of muscles joints tissues and membrane cells these are some of the body parts you activate and use during a yoga

**yoga anatomy academy online continuing ed classes** - Jun 04 2022

web oct 9 2023 3 agnistambhasana double pigeon or fire logs this seated variation of pigeon brings an intense stretch to your outer hips and as with other versions of the

[yoga anatomy for yoga teachers yoga journal](#) - Jun 16 2023

web aug 19 2018 yogapedia explains anatomy of yoga whether a yogi chooses to practice yoga for enlightenment recovery from an injury or to improve their overall fitness having

**anatomy applied to asana and yoga in general** - Jul 05 2022

web browse our extensive yoga pose library with a vast collection of basic poses advanced poses seated and standing poses twists and bandha techniques

**yogaanatomy net principles** - Nov 09 2022

web yoga anatomy academy takes an interdisciplinary approach to teaching yoga asana that emphasizes strength and function over pretty shapes see the full library online courses

*understanding your muscle tissue during yoga practice* - Jan 11 2023

web learn the importance of the breath and how it affects your practice in leslie kaminoff s workshop series the anatomy of yoga the yoga of anatomy leslie draws on his five

**human anatomy skeletal system yoga dunia lembongan** - Mar 01 2022

**spooky spookier step into reading by lori haskins houran** - Mar 02 2023

web jul 7 2015 read reviews and buy spooky spookier step into reading by lori haskins houran paperback at target choose

from same day delivery drive up or

**spooky definition usage examples dictionary com** - Jun 24 2022

web see synonyms for spooky spookiest on thesaurus com adjective spook i er spook i est informal like or befitting a spook or ghost suggestive of spooks

pdf spooky spookier four american ghost stories step into - Dec 31 2022

web step 4 readers use challenging vocabulary and short paragraphs to tell exciting stories for newly independent readers who read simple sentences with confidence en the

spooky spookier four american ghost stories step into - Feb 01 2023

web american history mixes with legend in four classic ghost tales for step 4 early readers a cape cod ghost horse that leads ships away from danger a portrait that protests being

**read spooky spookier four american ghost stories step into** - Sep 27 2022

web read read spooky spookier four american ghost stories step into reading online description the trusted literacy program with five steps to reading success

**download solutions spookyspookierstepintoreading** - Aug 27 2022

web the spooky cabin paw patrol jul 21 2023 when nicklelodoen s paw patrol uncover a ghostly mystery in an old cabin rubble rocky and chase are on the case boys and

*spooky spookier four american ghost stories step into* - Aug 07 2023

web jul 7 2015 spooky spookier four american ghost stories step into reading kindle edition by lori haskins houran author viviana diaz illustrator format kindle edition

**spookier definition and meaning collins english dictionary** - May 24 2022

web spookier definition ghostly or eerie meaning pronunciation translations and examples

**step into reading 4** **spooky spookier youtube** - Sep 08 2023

web feb 15 2023 about press copyright contact us creators advertise developers terms privacy policy safety how youtube works test new features nfl sunday ticket

**spooky spookier four american ghost stories step into reading** - Mar 22 2022

web decoding spooky spookier four american ghost stories step into reading revealing the captivating potential of verbal expression in a period characterized by

**amazon com customer reviews spooky amp spookier four** - Feb 18 2022

web find helpful customer reviews and review ratings for spooky spookier four american ghost stories step into reading at amazon com read honest and unbiased product

---

[spooky spookier four american ghost stories step into](#) - May 04 2023

web amazon in buy spooky spookier four american ghost stories step into reading book online at best prices in india on amazon in read spooky spookier four

**pdf top trend spooky and spookier four american ghost** - Jul 06 2023

web click here gedanggorengenak66788 blogspot com book 0553533967 best pdf spooky and spookier four american ghost stories step into reading download

[spooky spookier four american ghost stories step into](#) - Jun 05 2023

web spooky spookier four american ghost stories step into reading ebook houran lori haskins diaz viviana amazon com au kindle store

**pdf full download spooky spookier four american ghost** - Nov 29 2022

web may 2 2022 for ipad spooky spookier four american ghost stories step into reading for android spooky spookier four american ghost stories step into

[description spooky spoo yumpu](#) - Oct 29 2022

web jun 25 2022 spooky spookier four american ghost stories step into reading download ebook pdf epub book in english language download spooky

**spooky spookier four american ghost stories step** - Oct 09 2023

web jul 7 2015 spooky spookier four american ghost stories step into reading paperback picture book july 7 2015 by lori haskins houran author viviana diaz

[spooky spookier four american ghost stories step into](#) - Apr 03 2023

web add a gift card to your order choose your denomination

[spooky spookier step into reading](#) - Jul 26 2022

web it will enormously ease you to see guide spooky spookier step into reading as you such as by searching the title publisher or authors of guide you in fact want you can

*spookier definition of spookier by the free dictionary* - Apr 22 2022

web adj spook i er spook i est informal 1 suggestive of ghosts or spirits especially in being eerie or disturbing a spooky attic 2 easily startled skittish a spooky horse spook i ly

**wellcraft boats owner s manual pdf boat yacht manuals pdf** - Aug 27 2022

web wellcraft 270 coastal i o 250 coastal o b 270 coastal 0 b 35 ccf 29 ccf 252 coastal o b 32 ccf owner s manual pdf bill davis and ed crafton founded wellcraft marine corporation in 1955 in sarasota florida at first the company built wooden boats 14 17 feet long as well as smaller 12 foot scythians

[2000 wellcraft 3200 martinique boatingworld](#) - Nov 29 2022

web oct 17 2023 get the latest 2000 wellcraft 3200 martinique boat specs boat tests and reviews featuring specifications available features engine information fuel consumption price msrp and information resources boat manual looking for the boat manual click here related boats 1994 wellcraft 3200 martinique 1995 wellcraft 3200 martinique

[cruisers owner s manual wellcraft](#) - Oct 09 2023

web to the wellcraft family we want you to receive the most enjoyment possible from your new boat and the more you know about it the easier that will be it is important that you take the time to read this entire manual prior to taking your boat out for the first time also read all literature supplied with your boat by the manufacturers of the

[wellcraft 3200 martinique hmy yachts](#) - Oct 29 2022

web wellcraft 3200 martinique specifications name 3200 martinique length 32 hull type modified v gross weight fuel capacity 162 gals model years 1994 2000 draft 3 1 that pretty much describes the 3200 martinique a maxi volume express with attractive lines and a generic midcabin floorplan built on a solid fiberglass hull

[wellcraft martinique 3200 boats for sale smartmarineguide com](#) - Mar 22 2022

web 1996 wellcraft 3200 martinique powered with twin merc 5 7 blue water inboards with closed cooling 510 engine hours raytheon vhf pioneer stereo compass humminbird in dash depth finder ratheon fish finder l 470 furuno radar garmin gps map 541s bottom paint spotlight 3 step swim ladder city water hot cold transom shower snap in out

**1994 wellcraft martinique 3200 gordonville texas boats com** - Feb 18 2022

web nov 15 2001 wellcraft martinique 3200 for sale in gordonville texas view pictures and details of this boat or search for more wellcraft boats for sale on boats com wellcraft 2400 martinique and 2600 martinique two new compact cabin cruisers staff november 15 2001 boat reviews wellcraft 340 coastal multipurpose machine gary reich

[1439 wellcraft boat manual](#) - Sep 08 2023

web 3000 martinique l o a w pulpit 32 4 9 85m centerline length w o pulpit 30 6 9 3m beam 10 6 3 20m dry weight w engines approx 11 500 lbs 5216kg fuel capacity 160 gal 605 6l water capacity 41 gal 155 18l 1439 wellcraft boat manual author andrea baumann created date

[wellcraft cruisers owner s manual pdf download manualslib](#) - May 04 2023

web related manuals for wellcraft cruisers boat wellcraft 270 coastal owner s manual boats 121 pages boat wellcraft fisherman 180 owner s manual wellcraft marine 2400 martinique sarasota fl 34243 orange model design compliance with nmma requirements below is verified

**wellcraft 3200 martinique boats for sale yachtworld** - Jun 24 2022

web 1996 wellcraft martinique 3200 us 39 000 marina del rey california 32ft 1996 offered by purcell yachts contact 1995

wellcraft martinique 3200 us 14 900 price drop us 10 000 oct 12 salt lake city utah 32ft 1995 executive boat yacht brokerage  
1

**wellcraft owners product information guides** - Jun 05 2023

web wellcraft product information guides owners wellcraft product information guides 2022

1994 wellcraft marine 3200 martinique iboats - Sep 27 2022

web 1994 wellcraft marine 3200 martinique the 1994 3200 martinique is a 32 foot inboard outboard boat the weight of the boat is 10000 lbs which does not include passengers aftermarket boating accessories or fuel information on this page is provided to you as a free service of iboats com

**1439 wellcraft boat manual** - Dec 31 2022

web 2400 martinique l o a 24 7 7 49m beam 8 6 2 59m dry weight with engine approx 6000 lbs 2722kg fuel capacity 84 gal 317 9l max power prop 280 hp 209kw water capacity 26 gal 98 4l holding tank capacity 12 gal 45 4l deadrise 20 draft up approx 24 61m draft down approx 35 89m bridge clearance to bimini

**1995 wellcraft martinique 3200 specs and pricing** - May 24 2022

web wellcraft martinique 3200 manual engine and power specs engine manufacturer volvo penta engine series dp 290 engine location inboard outboard engine hours 6 parts and accessories wellcraft martinique 3200 parts engine built year 2020 dimensions and wieght loa length overall 9 75 m 32 00 ft

1995 wellcraft 3200 martinique boatingworld - Mar 02 2023

web oct 21 2023 get the latest 1995 wellcraft 3200 martinique boat specs boat tests and reviews featuring specifications available features engine information fuel consumption price msrp and information resources boat manual looking for the boat manual click here related boats 1994 wellcraft 3200 martinique 1996 wellcraft 3200 martinique

**1439 wellcraft boat manual** - Feb 01 2023

web 3700 martinique l o a 36 11 11 25m beam 13 0 3 96m dry weight approx w engine 16 800 lbs 7620kg fuel capacity 266 gal 1007l water capacity 57 gal 216l holding tank capacity 35 gal 132l max power 760 hp 567kw deadrise 22 draft approx 40 1 02m bridge clearance w radar arch 9 5 2 87m bridge clearance

wellcraft owners owners manuals - Jul 06 2023

web 2017 wellcraft owner s manual download now 2016 wellcraft seating chart download now 2016 wellcraft owner s manual download now 2014 wellcraft owner s manual download now owner s manual coastal 210 download now owner s manual coastal 232 252 download now owner s manual coastal 270

1999 wellcraft 3200 martinique boatingworld - Apr 03 2023

web get the latest 1999 wellcraft 3200 martinique boat specs boat tests and reviews featuring specifications available

features engine information fuel consumption price msrp and information resources boat manual looking for the boat manual click here related boats 1994 wellcraft 3200 martinique 1995 wellcraft 3200 martinique

*best wellcraft martinique 3200 boats for sale boat trader - Apr 22 2022*

web got a specific wellcraft martinique 3200 in mind there are currently 5 listings available on boat trader by both private sellers and professional boat dealers of those available we have 2 new and 3 used the oldest boat was built in 1989 and the newest model is 1999 the starting price is 14 900 the most expensive is 44 350 and the

*wellcraft 1997 32 wellcraft 3200 martinique - Jul 26 2022*

web builder wellcraft year built 1997 model cruiser price price on application location united states loa 32 0 9 75m beam 11 2 3 40m max draft 3 0 0 91m 1997 32 wellcraft 3200 martinique wellcraft our experienced yacht broker andrey shestakov will help you choose and buy a yacht that best suits your needs

*1995 martinique 3200 owners manual wellcraft boat owners - Aug 07 2023*

web dec 13 2020 posts 1 joined fri dec 11 2020 9 55 pm vessel info 3200 martinique 1995 martinique 3200 owners manual postby 95 martinique fri dec 11 2020 10 23 pm anyone know where i can find a owners manual for a 1995 3200 martinique just bought the boat and looking for help with getting the book so i can get to know the boat thanks