

Electric pump EP 1

The EMAG-MAX electric automatic pump model EP 1 is electrically controlled and has up to a maximum of 3 independently operating automatic outlets. It operates pump unit is suitable for dust water. The pump unit can maintain 10-120 or 10-150 l per Page 2) so that the automatic outlets can be adapted to the requirements of individual separate distribution areas.

These pumps include the delivery of compressed air (max. 10 bar) for a working pressure of maximum 100 bar (pressure-rated construction).

The EP 1 series pumps offer a constant and low control type (EP 1) and the automatic pressure, e.g. the PTC or the automatic control unit (EP 1) whereby the pump unit can be adjusted with a control of different integrated modules.

Integrated modules:

- EP 1
- EP 2
- EP 3
- EP 4
- EP 5
- EP 6
- EP 7
- EP 8

Technical data:

Power	
Operating voltage	110V / 230V AC
Flow	10 l/min
Control system	
Output 1 (EP 1)	0.60 / 0.60
Output 2 (EP 2)	0.60 / 1.10
Flow	14 / 14

Flow	
Flow operating pressure	100 bar
Pressure relief valve setting	100 bar
Permissible operating temperature	0°C to 100°C
Control system	
Temperature control	1-10 kg, 2-10 kg, 3-10 kg
Flow control	Flow-100
Flow direction	Reverse
Mounting position	Horizontal or vertical
Delivery rate of compressed air	
EP 1	1.000 l/min at 10 bar
EP 2	1.000 l/min at 10 bar
EP 3	1.000 l/min at 10 bar

Accessories: Operating manual EP 1 (including user manual) (maximal delivery rate 100 l/min)

Electric pump EP 1 with 1 kg container



Electric pump EP 1 with 4 kg container and integrated pressure control



Operation:

A 20 bar (10 bar) pressure is applied to the pressure unit (1) and pressure (Fig. 2). The pressure, which the control and pressure system of the delivery system (2) controls, the integrated pressure control (3) controls. The delivery water flow being controlled out of the water line. The water (4) enters the automatic unit of the supply container through a pressure unit (5).

Control unit (1) controls, to the control unit (1) for pump (Fig. 2). A control on the water (2) enables a flow (4) of the delivery water out of the supply container (5). The pressure relief valve (3) controls the pressure.

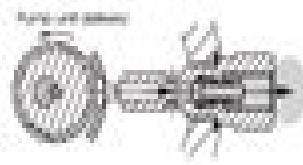
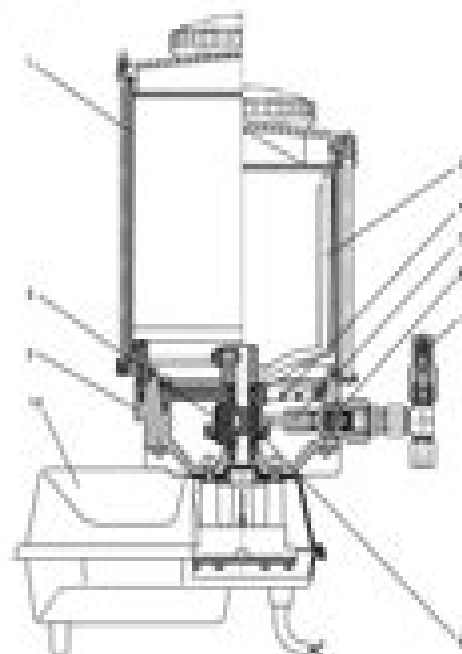

Liebherr Parts Manual

D.J. Edwards, F.C. Harris, Ron McCaffer

Liebherr Parts Manual:

Fuel your quest for knowledge with Learn from is thought-provoking masterpiece, **Liebherr Parts Manual** . This educational ebook, conveniently sized in PDF (*), is a gateway to personal growth and intellectual stimulation. Immerse yourself in the enriching content curated to cater to every eager mind. Download now and embark on a learning journey that promises to expand your horizons. .

https://py.bijouxmedusa.com/data/scholarship/default.aspx/Estate_Investing_Step_By_Step_America_6_917_Real_Estate_Investing.pdf

Table of Contents Liebherr Parts Manual

1. Understanding the eBook Liebherr Parts Manual
 - The Rise of Digital Reading Liebherr Parts Manual
 - Advantages of eBooks Over Traditional Books
2. Identifying Liebherr Parts Manual
 - Exploring Different Genres
 - Considering Fiction vs. Non-Fiction
 - Determining Your Reading Goals
3. Choosing the Right eBook Platform
 - Popular eBook Platforms
 - Features to Look for in an Liebherr Parts Manual
 - User-Friendly Interface
4. Exploring eBook Recommendations from Liebherr Parts Manual
 - Personalized Recommendations
 - Liebherr Parts Manual User Reviews and Ratings
 - Liebherr Parts Manual and Bestseller Lists
5. Accessing Liebherr Parts Manual Free and Paid eBooks
 - Liebherr Parts Manual Public Domain eBooks
 - Liebherr Parts Manual eBook Subscription Services

- Liebherr Parts Manual Budget-Friendly Options
- 6. Navigating Liebherr Parts Manual eBook Formats
 - ePub, PDF, MOBI, and More
 - Liebherr Parts Manual Compatibility with Devices
 - Liebherr Parts Manual Enhanced eBook Features
- 7. Enhancing Your Reading Experience
 - Adjustable Fonts and Text Sizes of Liebherr Parts Manual
 - Highlighting and Note-Taking Liebherr Parts Manual
 - Interactive Elements Liebherr Parts Manual
- 8. Staying Engaged with Liebherr Parts Manual
 - Joining Online Reading Communities
 - Participating in Virtual Book Clubs
 - Following Authors and Publishers Liebherr Parts Manual
- 9. Balancing eBooks and Physical Books Liebherr Parts Manual
 - Benefits of a Digital Library
 - Creating a Diverse Reading Collection Liebherr Parts Manual
- 10. Overcoming Reading Challenges
 - Dealing with Digital Eye Strain
 - Minimizing Distractions
 - Managing Screen Time
- 11. Cultivating a Reading Routine Liebherr Parts Manual
 - Setting Reading Goals Liebherr Parts Manual
 - Carving Out Dedicated Reading Time
- 12. Sourcing Reliable Information of Liebherr Parts Manual
 - Fact-Checking eBook Content of Liebherr Parts Manual
 - Distinguishing Credible Sources
- 13. Promoting Lifelong Learning
 - Utilizing eBooks for Skill Development
 - Exploring Educational eBooks
- 14. Embracing eBook Trends

- Integration of Multimedia Elements
- Interactive and Gamified eBooks

Liebherr Parts Manual Introduction

Free PDF Books and Manuals for Download: Unlocking Knowledge at Your Fingertips In today's fast-paced digital age, obtaining valuable knowledge has become easier than ever. Thanks to the internet, a vast array of books and manuals are now available for free download in PDF format. Whether you are a student, professional, or simply an avid reader, this treasure trove of downloadable resources offers a wealth of information, conveniently accessible anytime, anywhere. The advent of online libraries and platforms dedicated to sharing knowledge has revolutionized the way we consume information. No longer confined to physical libraries or bookstores, readers can now access an extensive collection of digital books and manuals with just a few clicks. These resources, available in PDF, Microsoft Word, and PowerPoint formats, cater to a wide range of interests, including literature, technology, science, history, and much more. One notable platform where you can explore and download free Liebherr Parts Manual PDF books and manuals is the internet's largest free library. Hosted online, this catalog compiles a vast assortment of documents, making it a veritable goldmine of knowledge. With its easy-to-use website interface and customizable PDF generator, this platform offers a user-friendly experience, allowing individuals to effortlessly navigate and access the information they seek. The availability of free PDF books and manuals on this platform demonstrates its commitment to democratizing education and empowering individuals with the tools needed to succeed in their chosen fields. It allows anyone, regardless of their background or financial limitations, to expand their horizons and gain insights from experts in various disciplines. One of the most significant advantages of downloading PDF books and manuals lies in their portability. Unlike physical copies, digital books can be stored and carried on a single device, such as a tablet or smartphone, saving valuable space and weight. This convenience makes it possible for readers to have their entire library at their fingertips, whether they are commuting, traveling, or simply enjoying a lazy afternoon at home. Additionally, digital files are easily searchable, enabling readers to locate specific information within seconds. With a few keystrokes, users can search for keywords, topics, or phrases, making research and finding relevant information a breeze. This efficiency saves time and effort, streamlining the learning process and allowing individuals to focus on extracting the information they need. Furthermore, the availability of free PDF books and manuals fosters a culture of continuous learning. By removing financial barriers, more people can access educational resources and pursue lifelong learning, contributing to personal growth and professional development. This democratization of knowledge promotes intellectual curiosity and empowers individuals to become lifelong learners, promoting progress and innovation in various fields. It is worth noting that while accessing free Liebherr Parts Manual PDF books and manuals is convenient and cost-effective, it is vital to respect copyright

laws and intellectual property rights. Platforms offering free downloads often operate within legal boundaries, ensuring that the materials they provide are either in the public domain or authorized for distribution. By adhering to copyright laws, users can enjoy the benefits of free access to knowledge while supporting the authors and publishers who make these resources available. In conclusion, the availability of Liebherr Parts Manual free PDF books and manuals for download has revolutionized the way we access and consume knowledge. With just a few clicks, individuals can explore a vast collection of resources across different disciplines, all free of charge. This accessibility empowers individuals to become lifelong learners, contributing to personal growth, professional development, and the advancement of society as a whole. So why not unlock a world of knowledge today? Start exploring the vast sea of free PDF books and manuals waiting to be discovered right at your fingertips.

FAQs About Liebherr Parts Manual Books

1. Where can I buy Liebherr Parts Manual books? Bookstores: Physical bookstores like Barnes & Noble, Waterstones, and independent local stores. Online Retailers: Amazon, Book Depository, and various online bookstores offer a wide range of books in physical and digital formats.
2. What are the different book formats available? Hardcover: Sturdy and durable, usually more expensive. Paperback: Cheaper, lighter, and more portable than hardcovers. E-books: Digital books available for e-readers like Kindle or software like Apple Books, Kindle, and Google Play Books.
3. How do I choose a Liebherr Parts Manual book to read? Genres: Consider the genre you enjoy (fiction, non-fiction, mystery, sci-fi, etc.). Recommendations: Ask friends, join book clubs, or explore online reviews and recommendations. Author: If you like a particular author, you might enjoy more of their work.
4. How do I take care of Liebherr Parts Manual books? Storage: Keep them away from direct sunlight and in a dry environment. Handling: Avoid folding pages, use bookmarks, and handle them with clean hands. Cleaning: Gently dust the covers and pages occasionally.
5. Can I borrow books without buying them? Public Libraries: Local libraries offer a wide range of books for borrowing. Book Swaps: Community book exchanges or online platforms where people exchange books.
6. How can I track my reading progress or manage my book collection? Book Tracking Apps: Goodreads, LibraryThing, and Book Catalogue are popular apps for tracking your reading progress and managing book collections. Spreadsheets: You can create your own spreadsheet to track books read, ratings, and other details.

7. What are Liebherr Parts Manual audiobooks, and where can I find them? Audiobooks: Audio recordings of books, perfect for listening while commuting or multitasking. Platforms: Audible, LibriVox, and Google Play Books offer a wide selection of audiobooks.
8. How do I support authors or the book industry? Buy Books: Purchase books from authors or independent bookstores. Reviews: Leave reviews on platforms like Goodreads or Amazon. Promotion: Share your favorite books on social media or recommend them to friends.
9. Are there book clubs or reading communities I can join? Local Clubs: Check for local book clubs in libraries or community centers. Online Communities: Platforms like Goodreads have virtual book clubs and discussion groups.
10. Can I read Liebherr Parts Manual books for free? Public Domain Books: Many classic books are available for free as they're in the public domain. Free E-books: Some websites offer free e-books legally, like Project Gutenberg or Open Library.

Find Liebherr Parts Manual :

[estate investing step by step America 6-917](#) [real estate investing 6-2663](#) [self improvement roadmap for entrepreneurs 6-2382](#) [self](#)

estate investing apps for small business 6-2157 [real estate investing](#)

[YouTube growth ideas for creators 6-155](#) [YouTube growth ideas for small](#)

privacy case study USA 6-134 [online privacy case study for startups](#)

[Instagram growth examples for startups 6-2445](#) [Instagram growth explained](#)

small business 6-1264 [TikTok marketing tools for small business 6-2171](#)

6-2636 [remote work guide for startups 6-206](#) [remote work ideas United](#)

[hustles blueprint for startups 6-1794](#) [side hustles case study America](#)

6-585 [interview tips best practices America 6-1435](#) [interview tips best](#)

[United States 6-1676](#) [Instagram growth trends for startups 6-1707](#)

[personal finance best practices USA 6-1160](#) [personal finance best](#)

6-1728 [fitness routines apps USA 6-2630](#) [fitness routines apps United](#)

[routines step by step for startups 6-1626](#) [fitness routines strategies](#)

entrepreneurs 6-1076 [fitness routines review for small business 6-2985](#)

Liebherr Parts Manual :

Campbell Biology: Concepts and Connections - 9th Edition Our resource for Campbell Biology: Concepts and Connections includes answers to chapter exercises, as well as detailed information to walk you through the ... Campbell Biology: Concepts & Connections 9th Edition ... Campbell Biology: Concepts & Connections 9th Edition Textbook Solutions | Chegg.com. We have solutions for your book! Campbell Biology: Concepts & Connections | 7th Edition By Verified Textbook Solutions. Need answers to Campbell Biology: Concepts & Connections 7th Edition published by Pearson? Get help now with immediate access ... Campbell Biology: Concepts & Connections (9th Edition) Access all of the textbook solutions and explanations for Cain/Urry's Campbell Biology: Concepts & Connections (9th Edition). 02 test bank 2 - Wheatley biology test answer keys. Wheatley biology test answer keys. biology: concepts and connections, 7e (reece et al.) chapter the chemical basis of life questions the four most common. Test Bank and Solutions For Campbell Biology, Concepts ... Test Bank, Solutions Manual, Ebook for Campbell Biology, Concepts & Connections 10th Edition By Martha Taylor ; 9780136538820, 9780136539414, 0136539416, Test Bank For Campbell Biology Concepts Connections ... Test Bank for Campbell Biology Concepts Connections 9th Edition 9th ... O Level Biology Practice Questions And Answers: Ecology And Our Impact On The Ecosystem. Chapter 7 Campbell's Biology: Concepts and Connections, 7e (Reece et al.) Chapter 7 Photosynthesis: Using Light to Make Food. 7.1 Multiple-Choice Questions. 1) What is ... Campbell Biology Concepts And Connections Sep 18, 2023 — In a digital era where connections and knowledge reign supreme, the enchanting power of language has be much more apparent than ever. Active Reading Guide for CAMPBELL BIOLOGY Answer the following questions as you read modules 5.1-5.9: 1. Every cell ... How is this possible? ConnECTIng THE Big IDEAs. Use your knowledge of the ... Accidental Love by Gary Soto THE BOOK ACCIDENTAL LOVE IS ABOUT 2 GIRLS MARISA AND ALICIA. ALICIA GOT IN TO AN ACCIDENT WITH HER BOYFRIEND AND SHE IS A LITTLE BIT BAD,MARISA ALWAYS HAVE ... Accidental Love - Soto, Gary: Books A series of misguided actions to take revenge for her friend Alicia, Rene steps in to stop the fight. Marisa and Rene inadvertently grab each other's cellphones ... Accidental Love by Gary Soto This book is about how a girl loved a guy but then she git in a car crash and when she did a picture fell out of her boyfriend with another girl. So then they ... ACCIDENTAL LOVE Marisa is in her first year of high school, a little overweight and always ready to pick a fight. After punching her best friend's cheating boyfriend in an ... Accidental Love An unplanned meeting between Marissa and Rene, a player whose only game is chess, causes sparks to fly. Marissa may start out believing that "Dang, the boy's a ... Accidental Love - Gary Soto Filled with all of the drama and angst that puberty, school, friends and self-image can create, this ultimately is a story of self-worth and realization, love ... Accidental Love - Gary Soto Accidental Love ... It all starts when Marisa picks up the wrong cell phone. When she returns it to Rene, she feels curiously drawn to him. But Marisa and Rene ... Accidental Love book by Gary Soto It all starts when Marisa picks up the wrong cell phone. When she goes to return it, she feels something she's never felt before,

something a bit like ... Accidental Love by Gary Soto, Paperback It all starts when Marisa picks up the wrong cell phone. When she returns it to Rene, she feels curiously drawn to him. But Marisa and Rene aren't exactly. Accidental Love by Gary Soto It all starts when Marisa picks up the wrong cell phone. When she returns it to Rene, she feels curiously drawn to him. But Marisa and Rene aren't exactly a ... Hyundai Tucson Repair & Service Manuals (99 PDF's Hyundai Tucson service PDF's covering routine maintenance and servicing; Detailed Hyundai Tucson Engine and Associated Service Systems (for Repairs and Overhaul) ... Manuals & Warranties | Hyundai Resources The manuals and warranties section of the MyHyundai site will show owners manual information as well as warranty information for your Hyundai. Free Hyundai Tucson Factory Service Manuals / Repair Manuals Download Free Hyundai Tucson PDF factory service manuals. To download a free repair manual, locate the model year you require above, then visit the page to view ... Hyundai Tucson First Generation PDF Workshop Manual Factory workshop and service manual for the Hyundai Tucson, built between 2004 and 2009. Covers all aspects of vehicle repair, including maintenance, servicing, ... Factory Repair Manual? Mar 8, 2023 — I was looking for a repair manual for my 2023 Tucson hybrid SEL, like a Chilton or Haynes, but they don't make one. Repair manuals and video tutorials on HYUNDAI TUCSON HYUNDAI TUCSON PDF service and repair manuals with illustrations. HYUNDAI Tucson (NX4, NX4E) workshop manual online. How to change front windshield wipers ... Hyundai Tucson TL 2015-2019 Workshop Manual + ... Hyundai Tucson TL 2015-2019 Workshop Manual + Owner's Manual - Available for free download (PDF) hyundai tucson tl 2015-2018 workshop service repair ... HYUNDAI TUCSON TL 2015-2018 WORKSHOP SERVICE REPAIR MANUAL (DOWNLOAD PDF COPY)THIS MANUAL IS COMPATIBLE WITH THE FOLLOWING COMPUTER ... 2021-2024 Hyundai Tucson (NX4) Workshop Manual + ... 2021-2024 Hyundai Tucson (NX4) Workshop Manual + Schematic Diagrams - Available for free download (PDF) Owner's Manual - Hyundai Maintenance Do you need your Hyundai vehicle's manual? Get detailed information in owner's manuals here. See more.