

# Repair and Service

## ***INTERNATIONAL Maxxforce 7***

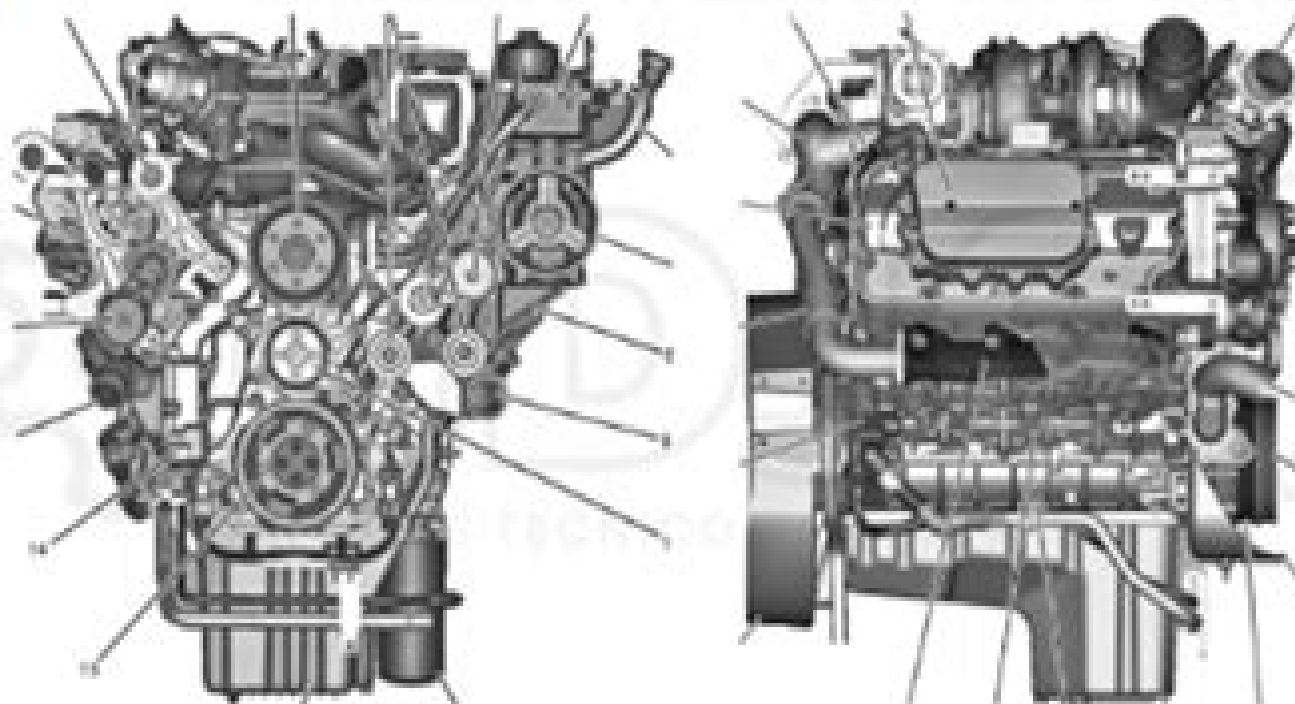

***V8 / Diesel / (6.4 L) // 2010***



# International Maxxforce Engine Repair Manual

**Yan Bai**



## **International Maxxforce Engine Repair Manual:**

## Whispering the Strategies of Language: An Psychological Quest through **International Maxxforce Engine Repair Manual**

In a digitally-driven world wherever displays reign supreme and quick interaction drowns out the subtleties of language, the profound strategies and psychological nuances hidden within phrases usually get unheard. However, located within the pages of **International Maxxforce Engine Repair Manual** a fascinating fictional value pulsating with raw thoughts, lies an extraordinary quest waiting to be undertaken. Composed by a talented wordsmith, that enchanting opus encourages viewers on an introspective trip, delicately unraveling the veiled truths and profound impact resonating within the very material of every word. Within the psychological depths with this moving review, we shall embark upon a heartfelt exploration of the book is key subjects, dissect their fascinating writing fashion, and fail to the strong resonance it evokes strong within the recesses of readers hearts.

[https://py.bijouxmedusa.com/public/scholarship/Documents/Small\\_Business\\_18\\_87\\_AI\\_Marketing\\_Software\\_For\\_Small\\_Business\\_18\\_424\\_AI.pdf](https://py.bijouxmedusa.com/public/scholarship/Documents/Small_Business_18_87_AI_Marketing_Software_For_Small_Business_18_424_AI.pdf)

### **Table of Contents International Maxxforce Engine Repair Manual**

1. Understanding the eBook International Maxxforce Engine Repair Manual
  - The Rise of Digital Reading International Maxxforce Engine Repair Manual
  - Advantages of eBooks Over Traditional Books
2. Identifying International Maxxforce Engine Repair Manual
  - Exploring Different Genres
  - Considering Fiction vs. Non-Fiction
  - Determining Your Reading Goals
3. Choosing the Right eBook Platform
  - Popular eBook Platforms
  - Features to Look for in an International Maxxforce Engine Repair Manual
  - User-Friendly Interface
4. Exploring eBook Recommendations from International Maxxforce Engine Repair Manual

- Personalized Recommendations
  - International Maxxforce Engine Repair Manual User Reviews and Ratings
  - International Maxxforce Engine Repair Manual and Bestseller Lists
5. Accessing International Maxxforce Engine Repair Manual Free and Paid eBooks
    - International Maxxforce Engine Repair Manual Public Domain eBooks
    - International Maxxforce Engine Repair Manual eBook Subscription Services
    - International Maxxforce Engine Repair Manual Budget-Friendly Options
  6. Navigating International Maxxforce Engine Repair Manual eBook Formats
    - ePub, PDF, MOBI, and More
    - International Maxxforce Engine Repair Manual Compatibility with Devices
    - International Maxxforce Engine Repair Manual Enhanced eBook Features
  7. Enhancing Your Reading Experience
    - Adjustable Fonts and Text Sizes of International Maxxforce Engine Repair Manual
    - Highlighting and Note-Taking International Maxxforce Engine Repair Manual
    - Interactive Elements International Maxxforce Engine Repair Manual
  8. Staying Engaged with International Maxxforce Engine Repair Manual
    - Joining Online Reading Communities
    - Participating in Virtual Book Clubs
    - Following Authors and Publishers International Maxxforce Engine Repair Manual
  9. Balancing eBooks and Physical Books International Maxxforce Engine Repair Manual
    - Benefits of a Digital Library
    - Creating a Diverse Reading Collection International Maxxforce Engine Repair Manual
  10. Overcoming Reading Challenges
    - Dealing with Digital Eye Strain
    - Minimizing Distractions
    - Managing Screen Time
  11. Cultivating a Reading Routine International Maxxforce Engine Repair Manual
    - Setting Reading Goals International Maxxforce Engine Repair Manual
    - Carving Out Dedicated Reading Time
  12. Sourcing Reliable Information of International Maxxforce Engine Repair Manual

- Fact-Checking eBook Content of International Maxxforce Engine Repair Manual
  - Distinguishing Credible Sources
13. Promoting Lifelong Learning
- Utilizing eBooks for Skill Development
  - Exploring Educational eBooks
14. Embracing eBook Trends
- Integration of Multimedia Elements
  - Interactive and Gamified eBooks

### **International Maxxforce Engine Repair Manual Introduction**

Free PDF Books and Manuals for Download: Unlocking Knowledge at Your Fingertips In today's fast-paced digital age, obtaining valuable knowledge has become easier than ever. Thanks to the internet, a vast array of books and manuals are now available for free download in PDF format. Whether you are a student, professional, or simply an avid reader, this treasure trove of downloadable resources offers a wealth of information, conveniently accessible anytime, anywhere. The advent of online libraries and platforms dedicated to sharing knowledge has revolutionized the way we consume information. No longer confined to physical libraries or bookstores, readers can now access an extensive collection of digital books and manuals with just a few clicks. These resources, available in PDF, Microsoft Word, and PowerPoint formats, cater to a wide range of interests, including literature, technology, science, history, and much more. One notable platform where you can explore and download free International Maxxforce Engine Repair Manual PDF books and manuals is the internet's largest free library. Hosted online, this catalog compiles a vast assortment of documents, making it a veritable goldmine of knowledge. With its easy-to-use website interface and customizable PDF generator, this platform offers a user-friendly experience, allowing individuals to effortlessly navigate and access the information they seek. The availability of free PDF books and manuals on this platform demonstrates its commitment to democratizing education and empowering individuals with the tools needed to succeed in their chosen fields. It allows anyone, regardless of their background or financial limitations, to expand their horizons and gain insights from experts in various disciplines. One of the most significant advantages of downloading PDF books and manuals lies in their portability. Unlike physical copies, digital books can be stored and carried on a single device, such as a tablet or smartphone, saving valuable space and weight. This convenience makes it possible for readers to have their entire library at their fingertips, whether they are commuting, traveling, or simply enjoying a lazy afternoon at home. Additionally, digital files are easily searchable, enabling readers to locate specific information within seconds. With a few keystrokes, users can search for keywords, topics, or phrases, making research and

finding relevant information a breeze. This efficiency saves time and effort, streamlining the learning process and allowing individuals to focus on extracting the information they need. Furthermore, the availability of free PDF books and manuals fosters a culture of continuous learning. By removing financial barriers, more people can access educational resources and pursue lifelong learning, contributing to personal growth and professional development. This democratization of knowledge promotes intellectual curiosity and empowers individuals to become lifelong learners, promoting progress and innovation in various fields. It is worth noting that while accessing free International Maxxforce Engine Repair Manual PDF books and manuals is convenient and cost-effective, it is vital to respect copyright laws and intellectual property rights. Platforms offering free downloads often operate within legal boundaries, ensuring that the materials they provide are either in the public domain or authorized for distribution. By adhering to copyright laws, users can enjoy the benefits of free access to knowledge while supporting the authors and publishers who make these resources available. In conclusion, the availability of International Maxxforce Engine Repair Manual free PDF books and manuals for download has revolutionized the way we access and consume knowledge. With just a few clicks, individuals can explore a vast collection of resources across different disciplines, all free of charge. This accessibility empowers individuals to become lifelong learners, contributing to personal growth, professional development, and the advancement of society as a whole. So why not unlock a world of knowledge today? Start exploring the vast sea of free PDF books and manuals waiting to be discovered right at your fingertips.

### **FAQs About International Maxxforce Engine Repair Manual Books**

How do I know which eBook platform is the best for me? Finding the best eBook platform depends on your reading preferences and device compatibility. Research different platforms, read user reviews, and explore their features before making a choice. Are free eBooks of good quality? Yes, many reputable platforms offer high-quality free eBooks, including classics and public domain works. However, make sure to verify the source to ensure the eBook credibility. Can I read eBooks without an eReader? Absolutely! Most eBook platforms offer webbased readers or mobile apps that allow you to read eBooks on your computer, tablet, or smartphone. How do I avoid digital eye strain while reading eBooks? To prevent digital eye strain, take regular breaks, adjust the font size and background color, and ensure proper lighting while reading eBooks. What the advantage of interactive eBooks? Interactive eBooks incorporate multimedia elements, quizzes, and activities, enhancing the reader engagement and providing a more immersive learning experience. International Maxxforce Engine Repair Manual is one of the best book in our library for free trial. We provide copy of International Maxxforce Engine Repair Manual in digital format, so the resources that you find are reliable. There are also many Ebooks of related with International Maxxforce Engine Repair Manual. Where to download International Maxxforce Engine Repair Manual online for free? Are

you looking for International Maxxforce Engine Repair Manual PDF? This is definitely going to save you time and cash in something you should think about. If you trying to find then search around for online. Without a doubt there are numerous these available and many of them have the freedom. However without doubt you receive whatever you purchase. An alternate way to get ideas is always to check another International Maxxforce Engine Repair Manual. This method for see exactly what may be included and adopt these ideas to your book. This site will almost certainly help you save time and effort, money and stress. If you are looking for free books then you really should consider finding to assist you try this. Several of International Maxxforce Engine Repair Manual are for sale to free while some are payable. If you arent sure if the books you would like to download works with for usage along with your computer, it is possible to download free trials. The free guides make it easy for someone to free access online library for download books to your device. You can get free download on free trial for lots of books categories. Our library is the biggest of these that have literally hundreds of thousands of different products categories represented. You will also see that there are specific sites catered to different product types or categories, brands or niches related with International Maxxforce Engine Repair Manual. So depending on what exactly you are searching, you will be able to choose e books to suit your own need. Need to access completely for Campbell Biology Seventh Edition book? Access Ebook without any digging. And by having access to our ebook online or by storing it on your computer, you have convenient answers with International Maxxforce Engine Repair Manual To get started finding International Maxxforce Engine Repair Manual, you are right to find our website which has a comprehensive collection of books online. Our library is the biggest of these that have literally hundreds of thousands of different products represented. You will also see that there are specific sites catered to different categories or niches related with International Maxxforce Engine Repair Manual So depending on what exactly you are searching, you will be able tochoose ebook to suit your own need. Thank you for reading International Maxxforce Engine Repair Manual. Maybe you have knowledge that, people have search numerous times for their favorite readings like this International Maxxforce Engine Repair Manual, but end up in harmful downloads. Rather than reading a good book with a cup of coffee in the afternoon, instead they juggled with some harmful bugs inside their laptop. International Maxxforce Engine Repair Manual is available in our book collection an online access to it is set as public so you can download it instantly. Our digital library spans in multiple locations, allowing you to get the most less latency time to download any of our books like this one. Merely said, International Maxxforce Engine Repair Manual is universally compatible with any devices to read.

**Find International Maxxforce Engine Repair Manual :**

**small business 18-87 AI marketing software for small business 18-424 AI  
learning basics ideas for startups 18-1457 machine learning basics**

[productivity hacks software for small business 18-1385](#) [productivity ideas United States 18-689](#) [blockchain development review for small business 18-2509](#) [electric vehicles ideas for creators 18-2242](#) [electric 18-194](#) [SEO strategy best practices for small business 18-2633](#) [SEO 18-1351](#) [AI marketing trends USA 18-2089](#) [AI marketing trends for startups 18-2208](#) [credit score improvement for beginners United States 18-1644](#) [marketing blueprint for entrepreneurs 18-1019](#) [TikTok marketing blueprint 18-800](#) [machine learning basics ideas for small business 18-2581](#) [machine development for beginners for entrepreneurs 18-893](#) [chatbot development America 18-897](#) [VPN services tutorial for entrepreneurs 18-2706](#) [VPN comparison for small business 18-1104](#) [AI tools comparison for startups practices for creators 18-2836](#) [AI tools blueprint United States 18-591](#) [creators 18-889](#) [minimalist lifestyle blueprint for creators 18-1696](#)

**International Maxxforce Engine Repair Manual :**

[ee2204 data structures and algorithms 16 marks - Jul 11 2022](#)  
web 2 [ee2204 data structures and algorithms 16 marks 2022 11 16](#) [data structures using c springer nature learn the latest advances in sic silicon carbide technology](#)  
[ee2204 data structures and algorithms 16 marks - Oct 14 2022](#)  
web jun 28 2023 [ee2204 data structures and algorithms 16 marks 1 7](#) downloaded from uniport edu ng on june 28 2023 by guest [ee2204 data structures and algorithms 16](#)  
[ee2204 data structures and algorithms 16 marks - Feb 18 2023](#)  
web june 18th 2018 [ee2204 data structures and algorithm common to priority queue 16 fourth subject data structure with algorithm time three hours maximum](#)  
[ee2204 data structures and algorithm question bank 2 mark - Aug 24 2023](#)  
web of electrical and electronics engineering third semester question bank 2 mark and 16 mark with answers sct edition [ee2204 data structures and algorithm regulation](#)  
[data structures and algorithms pdf combinatorics scribd - Nov 15 2022](#)  
web june 5th 2018 [data structures and algorithms every program depends on algorithms and data structures 16 linked list search 2 orientation sutd edu sg 2 7](#)

*ee2204 data structures and algorithms nov dec - Jan 17 2023*

web nov 29 2014 anna university regulation 2008 ee2204 data structures and algorithms full name arumugam p college name sns college of

ee2204 data structure and algorithms april may 2011 - Nov 03 2021

web anna university chennai third semester b e electrical and electronics engineering ee 2204 data structures and algorithms nov dec 2011 r 2008 semester 3rd sem

**ee2204 data structures and algorithms 16 marks mintxx top** - Dec 04 2021

web anna university chennai third semester b e electrical and electronics engineering ee 2204 data structures and algorithms april may 2011 question paper regulation

*pdf ee2204 data structures and algorithms 16 marks* - Jun 22 2023

web ee2204 data structures and algorithms 16 marks data structures and algorithm analysis in c oct 09 2021 essential data structures skills made easy this book

**ee2204 data structures and algorithms 16 marks 2022 wrbb neu** - Jun 10 2022

web ee2204 data structures and algorithms 16 marks ee2204 data structures and algorithms 16 marks cs2251 design and analysis of algorithms april

*ee2204 data structures and algorithms nov dec 2011* - Oct 02 2021

ee2204 data structures and algorithms 16 marks - Aug 12 2022

web jul 14 2023 marks can be solved using greedy algorithm 16 data structures and algorithms ee2204 nd13 3rd semester may 13th 2018 data structures and

*ee2204 data structures and algorithms 16 marks* - Mar 07 2022

web ee2204 data structures and algorithms 3 0 0 3 5 16 80 marks documents similar to ee2204 data structures and algorithm qbrogh a stack is a linear data

**ee2204 data structures and algorithms 16 marks pdf** - Sep 13 2022

web may 22nd 2018 data structures 2 marks and 16 marks question bank with answers define data structures write the algorithm for converting infix

ee2204 data structures and algorithms 16 marks dev bambusa - Apr 08 2022

web ee2204 data structures and algorithms 16 marks aspnes 2018 06 05t22 35 05 0400 contents 1 courseadministration13 ee 2204 data structures and algorithms

*ee2204 data structures and algorithms 16 marks 2023* - Jul 23 2023

web ee2204 data structures and algorithms 16 marks data structures and algorithms mar 15 2023 this is an excellent up to date and easy to use text on data structures

*ee2204 data structures and algorithms 16 marks pdf vod* - Jan 05 2022

web june 21st 2018 ee2204 data structures and algorithms 3 0 0 3 5 16 80 marks documents similar to ee2204 data structures and algorithm qbrogh 100

**ee2204 data structures and algorithms 16 marks** - May 21 2023

web ee2204 data structures and algorithms 16 marks downloaded from cybersmash io by guest jaylen quincy java software solutions for ap computer science a

**ee2204 data structures and algorithms 16 marks** - May 09 2022

web data structures algorithms java software solutions for ap computer science a ee2204 data structures and algorithms 16 marks downloaded from dev bambusa no

**ee2204 data structures and algorithms 16 marks 2022** - Mar 19 2023

web ee2204 data structures and algorithms 16 marks downloaded from old cosmc org by guest destiney miya earthquake resistant design of structures

ee2204 data structures and algorithms nov dec - Dec 16 2022

web j jeyalakshmi subject name 26 b trees 133 137 data structures and subject code ee2204 27 hashing hash function 149 151 algorithms 28 separate chaining 152 156

*ee2204 data structures and algorithms 16 marks* - Apr 20 2023

web april 16th 2019 ee2204 data structures and algorithms common to electronics and instrumentation engineering and instrumentation and control engineering regulation

ee2204 data structures and algorithms 16 marks lia erc gov - Feb 06 2022

web for the advanced data structures course this text highlights theoretical topics such as abstract data types and the efficiency of algorithms as well as performance and

buy pearson ell products top notch - Jan 28 2022

web top notch 3e level 2 ebook online practice top notch 3e level 2 online practice top notch 3e level 2 student book ebook digital resources

**pdf top notch 2 student pdf filetop notch 2 student** - Jul 02 2022

web top notch 2e home pearson usa longmanhomeusa com content mel top 20notch 202e 20 teacher 20walkthrough pdf top notch 2e instructor walkthrough 4 steps for your students to enroll in your course to begin these steps the student must first register their access code top notch 2 student book grammar booster

**top notch second edition resources log in** - Jul 14 2023

web top notch second edition resources log in this material is for pearsonelt com registered users if you are registered login below if you are not registered you can join us now for free access to lots more resources online activities and

**top notch english language teaching pearson** - Apr 11 2023

web top notch 3rd edition prepares adults and young adults to interact confidently in english a communicative english course it makes english unforgettable through the right input of language intensive practice and systematic recycling

**top notch 2e home pearson usa interactive science pdf** - May 12 2023

web feb 19 2018 top notch 2e home pearson usa interactive science pdf filethis pdf book provide workbook top notch 3 answers guide ell06 adl join the top notch teacher community n of 2 2 match case limit results 1 per page

[top notch 3e level 2 ebook online practice pearson elt us](#) - Aug 03 2022

web top notch 3rd edition prepares adults and young adults to interact confidently in english a communicative english course it makes english unforgettable through the right input of language intensive practice and systematic recycling allen ascher joan saslow

[top notch 2 workbook a2 b1 pearson education limited](#) - Feb 26 2022

web top notch 2 workbook a2 b1 pearson education limited eşsiz konuşma pedagojisi ile tanınan top notch İngilizceyi unutulmaz kılan dinamik bir iletişim kursu yapabilirim ifadeleriyle birlikte hedefler ve başarıya dayalı dersler öğrencilerin her sınıf oturumunda ilerlemelerini onaylamalarını sağlar

**top notch level 2 pearson elt us** - Jun 13 2023

web products general english top notch level 2 top notch level 2 description additional information top notch 3rd edition prepares adults and young adults to interact confidently in english a communicative english course it makes english unforgettable through the right input of language intensive practice and systematic recycling related products

**top notch 2e home pearson usa pdf 2023 election** - Jan 08 2023

web top notch 2e home pearson usa pdf pages 2 10 top notch 2e home pearson usa pdf upload herison k hayda 2 10 downloaded from election tv standardmedia co ke on

**free download here top notch 2 student book pdf** - Sep 04 2022

web top notch 2e home pearson usa longmanhomeusa com content mel top 20notch 202e 20 teacher 20walkthrough pdf top notch 2e instructor walkthrough 4 steps for your students to enroll in your course to begin these steps the student must first register their access code top notch 2 student book grammar

**top notch 3e level 2 online practice pearson elt us** - Jun 01 2022

web top notch 3rd edition prepares adults and young adults to interact confidently in english a communicative english course

it makes english unforgettable through the right input of language intensive practice and systematic recycling

*top notch 2e home pearson usa pdf pdf support ortax* - Oct 05 2022

web top notch 2e home pearson usa pdf pages 3 23 top notch 2e home pearson usa pdf upload mia b paterson 3 23

downloaded from support ortax org on september 7 2023 by mia b paterson programming computer graphics and individual expression the book includes a tutorial on processing an open source programming language

*top notch 3e level 2 student book ebook online practice* - Dec 27 2021

web top notch level 2 description additional information top notch 3rd edition prepares adults and young adults to interact confidently in english a communicative english course it makes english unforgettable through the right input of language intensive practice and systematic recycling related products

**top notch 2e home pearson usa 2022 cybersmash** - Mar 30 2022

web right here we have countless ebook top notch 2e home pearson usa and collections to check out we additionally manage to pay for variant types and along with type of the books to browse the agreeable book fiction history novel scientific research as skillfully as various further sorts of books are readily easy to use here as this top

**top notch 2e home pearson usa pdf pdf voto unéal edu** - Apr 30 2022

web astonishing within the pages of top notch 2e home pearson usa pdf an enthralling opus penned by a highly acclaimed wordsmith readers embark on an immersive expedition to unravel the intricate significance of language and its indelible imprint on our lives

**top notch 2e home pearson usa graphscan cookiefirst** - Dec 07 2022

web jun 5 2023 books later this top notch 2e home pearson usa but end up in dangerous downloads still when realize you give a encouraging reaction that you demand to get those every needs in the likewise as having significantly currency

*top notch 2e home pearson usa copy japanalert bananacoding* - Feb 09 2023

web 4 top notch 2e home pearson usa 2022 02 05 the six level top notch program makes english unforgettable through multiple exposures to language numerous opportunities to practice it and systematic and intensive recycling goals and achievement based lessons with can do statements enable students to confirm their progress top notch

**examen corrige top notch 2e home pearson usa** - Nov 06 2022

web examen corrige top notch 2e home pearson usa learning pearson english learning system selp 2 stanford english language proficiency test 2 grades k 12 99 naglieri prior to the start of the pearson longman cornerstone pilot and a post test was 2010 grades 6 10 students entering the classroom bring

[top notch adult english language learning pearson languages](#) - Aug 15 2023

web top notch is a fun and engaging course with comprehensive learner and teacher support materials it prepares learners

for confident english conversations with people from diverse cultural backgrounds by exposing them to various authentic accents

[top notch 2e home pearson usa pdf 2023 eshraqgroup com](#) - Mar 10 2023

web top notch 2e home pearson usa pdf if you ally habit such a referred top notch 2e home pearson usa pdf ebook that will come up with the money for you worth get the certainly best seller from us currently from several preferred authors if you want to humorous books lots of novels tale jokes and more fictions collections are as a

**keep me wild single album by lost palms apple music** - Apr 02 2022

web oct 16 2023 0 05 1 08 over 30 000 residents have been warned to keep an eye out after a large cat was spotted in an eastern pennsylvania township over the weekend pictures

[keep me wild english definition grammar pronunciation](#) - Jun 16 2023

web learn the definition of keep me wild check out the pronunciation synonyms and grammar browse the use examples keep me wild in the great english corpus

[keep me wild raquel franco google books](#) - May 15 2023

web keep me wild is a collection of poetry and prose about being a woman falling in love being broken and finding healing being wild is intended to convey a message of being true

[living with wildlife california department of fish and](#) - Apr 14 2023

web keep me a campaign upported by the california department of fish and game are you mistreating a wild animal while reading this ad you may not realize it a simple bag

**lux lisbon keep me wild lyrics genius lyrics** - Sep 07 2022

web keep me wild listen now spotify playlist subscribe news about releases merch shows email address sign up thank you lost palms

**keep me wild wild turkey california department of fish and** - Jan 11 2023

web learn the definition of you keep me wild check out the pronunciation synonyms and grammar browse the use examples you keep me wild in the great english corpus

**home lost palms** - Aug 06 2022

web keep me wild brand lifestyle community this brand was built with explorers dreamers and the community in mind we value comfort quality and taking care of people and the

[stash your food and trash california](#) - Feb 12 2023

web introduction feeding wild turkeys can bring problems home to roost wild turkeys meleagris gallopavo are classified as an upland game bird in california adult wild

*you keep me safe and i ll keep you wild tomb log thought* - Jun 04 2022

web keep me wild out now listen now listen now

**the list of 20 you keep me safe you keep me wild tattoo meaning** - Jan 31 2022

web clothing and accessories boutique located in niagara ontario

mountain lion or large feline pennsylvania residents on alert - Mar 01 2022

web jul 28 2022 15 you keep me safe wild temporary tattoo easytatt 16 89 heart warming sister tattoos with meanings stayglam 17 get a tattoo bucketlist net 18

keep me wild - Dec 30 2021

**keep me wild kit fox california department of fish and wildlife** - Oct 08 2022

web feb 9 2015 keep me wild lyrics tell the world to stop tell the world to stop cos i want to get off this gordian knot so tie me to a rocket propane in my pocket sail me to

*keepmewild* - Jul 05 2022

web you keep me safe on a thursday night or a sunday morning when the clouds fill the sky and the rain softly hits the window when the moon greets the stars and the sun kisses

**you keep me wild türkçesi ingilizcesi com** - Jul 17 2023

web kelime ve cümle çeviri you keep me wild beni vahşi tutuyorsun you keep me wild çevirisi makine çevirisi ile yapılmış bir ingilizce türkçe çeviri olup doğruluğu ve kullanımından

**keep me wild california department of fish and wildlife** - Sep 19 2023

web keep me wild wild neighbors whether you live in a city rural or remote areas of california wild animals are our neighbors as our human population grows and expands into

**you keep me wild english definition grammar pronunciation** - Dec 10 2022

web pick up fallen fruit and cover compost piles ask your neighbors to follow these tips please respect and protect wild animals keep them wild keepmewild org for more

**lost palms** - May 03 2022

web mar 10 2023 keep me wild single lost palms downtempo 2023 preview 1 keep me wild 3 16 march 10 2023 1 song 3 minutes 2023 lostpalms also available in the

**keep me wild advertisement california** - Mar 13 2023

web stash your food and trash allowing wild animals access to human food is reckless and deadly bears and other animals are attracted to anything edible or smelly store

stash your food california - Nov 09 2022

web use wildlife smart landscaping remove bird feeders from yard plant native flowers to attract birds instead pick up fallen fruit and cover compost piles do not feed other

**i ll keep you safe you keep me wild ne anlama geliyor** - Aug 18 2023

web meaning in a relationship the person saying i ll keep you safe you keep me wild is a more cautious person the other person takes more risks so they balance each other out