

Multi-Domain Engineering for 5G

Subsystems must be designed and tested together

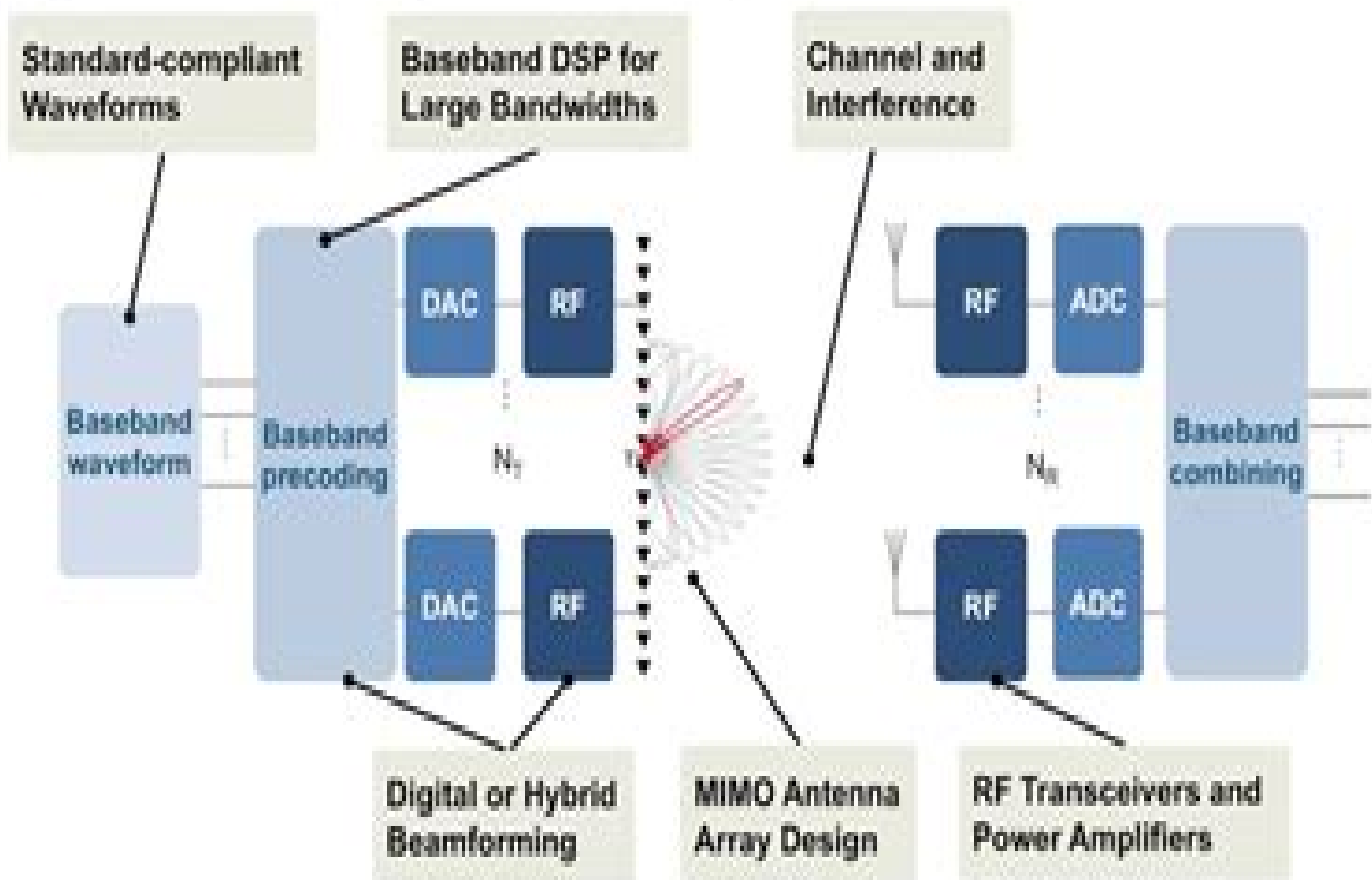

5g Wireless Technology Development Matlab Simulink

L Towne



5g Wireless Technology Development Matlab Simulink:

Advanced Wireless Communication and Sensor Networks Ashish Bagwari, Geetam Singh Tomar, Jyotshana Bagwari, Jorge Luis Victória Barbosa, Musti K.S. Sastry, 2023-07-12 This book covers wireless communication security issues advanced wireless sensor networks WSNs routing protocols of WSNs with cross layer solutions emerging trends in the advanced WSNs power management distributed sensing and data gathering techniques for WSNs WSNs security applications research of advanced WSNs with simulation results and simulation tools for WSNs Features Covers technologies supporting advanced wireless communication systems sensor networks and the conceptual development of the subject Discusses advanced data gathering and sharing distributed sensing techniques with its business applicability Includes numerous worked out mathematical equations and formulas as well as essential principles including figures illustrations algorithms and flow charts Provides pervasive background knowledge including both wireless communications and WSNs Covers wireless networks as well as sensor network models in detail This book is aimed at graduate students researchers and academics working in the field of computer science wireless communication technology and advanced WSNs Advanced Wireless Communication Systems: A Comprehensive Guide Sandeep Kumar Singh, Ashok Kumar, 2026-01-27 Advanced Wireless Communication Systems A Comprehensive Guide bridges foundational principles with emerging paradigms to present a unified and in depth exploration of the technologies architectures and innovations shaping contemporary and next generation wireless networks Opening with an overview of wireless technology evolution the book discusses global standards and regulatory frameworks for wireless networks while also systematically exploring wireless channel modelling simulation methodologies and a wide range of network architectures including cellular networks Wi Fi Bluetooth Zigbee LoRaWAN and IoT connectivity frameworks Advanced physical layer and system level technologies such as MIMO OFDM millimetre wave terahertz communication and free space optical systems are examined in detail along with critical security and privacy challenges in modern wireless networks Later chapters focus on future facing innovations including massive MIMO beamforming cognitive radio dynamic spectrum access and vehicular communication systems The book culminates with cutting edge topics such as machine learning driven network slicing latency optimisation for ultra reliable low latency communications URLLC and noncoherent system design targeting 6G class applications Key Features Comprehensive coverage from wireless communication fundamentals to cutting edge technologies An integrated perspective on wireless communication methods combining theory simulation methods and practical case studies Dedicated chapters on AI enabled optimisation cognitive radio and URLLC Clear illustrations comparative analyses and real world application insights **Recent Trends and Applications of Soft Computing in Engineering (RTASCE)— Sarajevo** Benjamin Duraković, Ali Abd Almisreb, Jasmin Šutković, 2025-04-29 Recent Trends and Applications of Soft Computing in Engineering RTASCE a key resource showcasing research and development in engineering Created at the inaugural RTASCE conference in Sarajevo this edited volume brings

together leading scholars and researchers to explore the transformative applications of soft computing in a variety of fields. With topics ranging from artificial intelligence and the Internet of Things (IoT) to machine learning, this book offers practical applications and insight into future trends, making it an invaluable addition to any academic library. This book bridges the biological sciences and engineering through programming, encouraging interdisciplinary collaboration. Structured into five main sections including artificial intelligence, IoT communication systems, bioengineering, and manufacturing management, RTASCE not only highlights real-world case studies and expert perspectives but also provides practical guidance for practitioners looking to integrate soft computing techniques into their work.

Signal Processing Techniques for Communication K.C. Raveendranathan, 2024-10-30. The reference text discusses signal processing tools and techniques used for the design, testing, and deployment of communication systems. It further explores software simulation and modeling tools like MATLAB, GNU Octave, Mathematica, and Python for modeling simulation and detailed analysis, leading to comprehensive insights into communication systems. The book explains topics such as source coding, pulse demodulation systems, and the principle of sampling and aliasing. This book discusses modern techniques including analog and digital filter design and modulation principles, including quadrature amplitude modulation and differential phase shift keying. Covers filter design using MATLAB system simulation using Simulink, signal processing toolbox, linear time invariant systems, and non-linear time variant systems. Explains important pulse keying techniques including Gaussian minimum shift keying and quadrature phase shift keying. Presents signal processing tools and techniques for communication systems design, modeling, simulation, and deployment. Illustrates topics such as software defined radio (SDR) systems, spectrum sensing, and automated modulation sensing. The text is primarily written for senior undergraduates, graduate students, and academic researchers in the fields of electrical engineering, electronics, and communication engineering, computer science, and engineering.

Vibration Engineering for a Sustainable Future Sebastian Oberst, Benjamin Halkon, Jinchun Ji, Terry Brown, 2020-12-19. This volume presents the proceedings of the Asia Pacific Vibration Conference (APVC) 2019, emphasizing work devoted to Vibration Engineering for a Sustainable Future. The APVC is one of the larger conferences held biannually with the intention to foster scientific and technical research collaboration among Asia Pacific countries. The APVC provides a forum for researchers, practitioners, and students from, but not limited to, areas around the Asia Pacific countries in a collegial and stimulating environment to present, discuss, and disseminate recent advances and new findings on all aspects of vibration and noise, their control, and utilization. All aspects of vibration, acoustics, vibration and noise control, vibration utilization, fault diagnosis, and monitoring are appropriate for the conference, with the focus this year on the vibration aspects in dynamics and noise. This 18th edition of the APVC was held in November 2019 in Sydney, Australia. The previous seventeen conferences have been held in Japan (85, 93, 07), Korea (87, 97, 13), China (89, 01, 11, 17), Australia (91, 03), Malaysia (95, 05), Singapore (99), New Zealand (09), and Vietnam (15).

Radio Receivers for Systems of Fixed and Mobile Communications Vasilij V.

Logvinov, Sergey M. Smolskiy, 2022-05-13 The textbook acquaints the reader with the architecture of receivers of analog and digital radio systems helps to study the stages of designing a modern radio receiver and reveals the reasons and methods for its effective operation in networks for various purposes Particular attention is paid to the methods of generating and processing signals in the receivers of digital systems with multiple access which make it possible to provide data transfer rates close to the maximum possible according to Shannon As a textbook for students studying methods of optimal signal reception the book will also be useful to specialists in the field of telecommunications involved in the development of radio receivers The book shows how the development of theoretical circuitry and integrated technologies led to the active introduction of algorithmic methods for signal processing changed both the design of receivers and the methods of forming the information flow in free space MIMO beamforming The creation of a global 5G network based on heterogeneous networks puts forward new requirements for the architecture of receivers which are determined by the requirements to achieve high data rates low time delays or use in networks with coordinated multipoint transmission and reception CoMP To consolidate the knowledge gained the book includes a complete set of materials for online classes including questions and answers a guide to solving problems for each chapter and computer modeling units of receivers in the MicroCAP environment based on preliminary calculations *Developing MATLAB Comprehensive Simulation for 5G/6G Wireless Communications* Phuong T. Tran, Tan N. Nguyen, Lam-Thanh Tu, 2026-01-08 This book introduces how to build an integrated simulation tool on the MATLAB platform to simulate advanced techniques at the physical layer of 5G and 6G networks such as modulation multiple access energy saving technologies massive MIMO physical layer security cognitive radio and artificial intelligence This simulation tool has a user friendly interactive interface with usage instructions and outputs graphs to evaluate the performance of each method The goal of the simulations is to achieve results related to performance indicators at the physical layer such as outage probability throughput bit error rate or frame error rate and security capacity This book helps the readers learn how to build a simulation framework for evaluating advanced 5G 6G technologies by themselves and apply them to their research **5G NR Modelling in MATLAB** Tulsi Pawan Fowdur, Madhavsingh Indoonundon, Dragorad A. Milovanovic, Zoran S. Bojkovic, 2024-06-30 5G is the fifth generation of wireless technology and NR stands for a new radio interface and radio access technology for cellular networks i e a physical connection method for radio based communication It is a powerful platform that supports a wide range of services that includes enhanced mobile broadband massive machine type communication and ultra reliability and low latency covering several vertical industries such as e health transportation energy media and factories automation This book provides a detailed description of the fundamental aspects of 5G It gives an in depth coverage of the network architecture of 5G by considering both the network reference point architecture and the service based architecture It also describes all the user and control plane protocols including the standalone and non standalone architecture options The radio access technologies such as the waveforms used in 5G the multi access and

duplexing techniques as well as the resource allocation schemes are treated in details. Additionally, the physical layer signal processing blocks of 5G NR are covered in depth with elaborate numerical examples to illustrate the functioning of each block in the 5G downlink transmitter and receiver chain. The main originality of this book is the detailed illustration of the 5G NR pre-processing steps as well as Matlab simulation models with explanation on the codes to allow for a seamless understanding of the principles. In general, this book is meant for anyone with a basic engineering background who would be interested to acquire a solid foundation in the fundamental concepts of 5G NR.

5G Wireless Systems Yang Yang, Jing Xu, Guang Shi, Cheng-Xiang Wang, 2017-09-14. This book focuses on key simulation and evaluation technologies for 5G systems. Based on the most recent research results from academia and industry, it describes the evaluation methodologies in depth for network and physical layer technologies. The evaluation methods are discussed in depth. It also covers the analysis of the 5G candidate technologies and the testing challenges, the evolution of the testing technologies, fading channel measurement and modeling, software simulations, software hardware cosimulation, field testing, and other novel evaluation methods. The fifth generation 5G mobile communications system targets highly improved network performances in terms of the network capacity and the number of connections. Testing and evaluation technologies is widely recognized and plays important roles in the wireless technology developments along with the research on basic theory and key technologies. The investigation and developments on the multi-level and comprehensive evaluations for 5G new technologies provides important performance references for the 5G technology filtering and future standardizations. Students focused on telecommunications, electronic engineering, computer science, or other related disciplines will find this book useful as a secondary text. Researchers and professionals working within these related fields will also find this book useful as a reference.

Cloud Based 5G Wireless Networks Yin Zhang, Min Chen, 2016-11-09. This SpringerBrief introduces key techniques for 5G wireless networks. The authors cover the development of wireless networks that led to 5G and how 5G mobile communication technology. 5G can no longer be defined by a single business model or a typical technical characteristic. The discussed networks, functions, and services include Network Foundation Virtualization, NFV, Cloud Radio Access Networks, Cloud RAN, and Mobile Cloud Networking (MCN). The benefits of cloud platforms are examined, as are definable networking and green wireless networking. Other related and representative projects on 5G are mobile and wireless communications enablers for the Twenty-Twenty Information Society: Multi-hop Cellular Networks, Network Function as a Service over Virtualized Infrastructures (iJOIN), and Nuage Virtualized Services Platform. Major applications of 5G range from RAN sharing and Multi-Operator Core Networks to mobile convergence. Enhancing the user experience by providing smart and customized services, 5G will support the explosive growth of big data, mobile internet, digital media, and system efficiency. This SpringerBrief is designed for professionals, researchers, and academics working in networks or system applications. Advanced level students of computer science or computer engineering will also find the content valuable.

Design Methodologies

and Tools for 5G Network Development and Application Suresh, P., Vairavel, G., Saravanakumar, U., 2020-12-25 The demand for mobile broadband will continue to increase in upcoming years largely driven by the need to deliver ultra high definition video 5G is not only evolutionary it also provides higher bandwidth and lower latency than the current generation technology More importantly 5G is revolutionary in that it is expected to enable fundamentally new applications with much more stringent requirements in latency and bandwidth 5G should help solve the last mile last kilometer problem and provide broadband access to the next billion users on earth at a much lower cost because of its use of new spectrum and its improvements in spectral efficiency 5G wireless access networks will need to combine several innovative aspects of decentralized and centralized allocation looking to maximize performance and minimize signaling load Research is currently conducted to understand the inspirations requirements and the promising technical options to boost and enrich activities in 5G Design Methodologies and Tools for 5G Network Development and Application presents the enhancement methods of 5G communication explores the methods for faster communication and provides a promising alternative solution that equips designers with the capability to produce high performance scalable and adoptable communication protocol This book provides complete design methodologies supporting tools for 5G communication and innovative works The design and evaluation of different proposed 5G structures signal integrity reliability low power techniques application mapping testing and future trends This book is ideal for researchers who are working in communication networks design and implementations industry personnel engineers practitioners academicians and students who are interested in the evolution importance usage and technology adoption for 5G applications [5G Outlook - Innovations and Applications](#) Ramjee Prasad, 2024-10-21

[Channel Modeling in 5G Wireless Communication Systems](#) Hao Jiang, Guan Gui, 2019-12-02 This book addresses the fundamental design and technical challenges for fifth generation 5G wireless channel models including multi frequency bands and multi scenarios The book presents a strong vision for 5G wireless communication networks based on current market trends proven technologies and future directions The book helps enable researchers and industry professionals to come up with novel ideas in the area of wireless heterogeneity to minimize traffic accidents to improve traffic efficiency and to foster the development of new applications such as mobile infotainment The book acts as a comprehensive reference for students instructors researchers engineers and other professionals building their understanding of 5G and in designing 5G systems Addresses fundamental design and technical challenges for 5G wireless channel models Presents how to create reliable statistical channel models to capture the propagation properties between transmitters and receivers Pertinent to researchers engineers and professionals in 5G [Fundamentals of 5G Mobile Networks](#) Jonathan Rodriguez, 2015-04-27 Fundamentals of 5G Mobile Networks provides an overview of the key features of the 5th Generation 5G mobile networks discussing the motivation for 5G and the main challenges in developing this new technology This book provides an insight into the key areas of research that will define this new system technology paving the path towards future research and

development The book is multi disciplinary in nature and aims to cover a whole host of intertwined subjects that will predominantly influence the 5G landscape including the future Internet cloud computing small cells and self organizing networks SONs cooperative communications dynamic spectrum management and cognitive radio Broadcast Broadband convergence 5G security challenge and green RF This book aims to be the first of its kind towards painting a holistic perspective on 5G Mobile allowing 5G stakeholders to capture key technology trends on different layering domains and to identify potential inter disciplinary design aspects that need to be solved in order to deliver a 5G Mobile system that operates seamlessly

Signal Processing for 5G Fa-Long Luo, Charlie Jianzhong Zhang, 2016-08-11 A comprehensive and invaluable guide to 5G technology implementation and practice in one single volume For all things 5G this book is a must read Signal processing techniques have played the most important role in wireless communications since the second generation of cellular systems It is anticipated that new techniques employed in 5G wireless networks will not only improve peak service rates significantly but also enhance capacity coverage reliability low latency efficiency flexibility compatibility and convergence to meet the increasing demands imposed by applications such as big data cloud service machine to machine M2M and mission critical communications This book is a comprehensive and detailed guide to all signal processing techniques employed in 5G wireless networks Uniquely organized into four categories New Modulation and Coding New Spatial Processing New Spectrum Opportunities and New System level Enabling Technologies it covers everything from network architecture physical layer down link and up link protocols and air interface to cell acquisition scheduling and rate adaption access procedures and relaying to spectrum allocations All technology aspects and major roadmaps of global 5G standard development and deployments are included in the book Key Features Offers step by step guidance on bringing 5G technology into practice by applying algorithms and design methodology to real time circuit implementation taking into account rapidly growing applications that have multi standards and multi systems Addresses spatial signal processing for 5G in particular massive multiple input multiple output massive MIMO FD MIMO and 3D MIMO along with orbital angular momentum multiplexing 3D beamforming and diversity Provides detailed algorithms and implementations and compares all multicarrier modulation and multiple access schemes that offer superior data transmission performance including FBMC GFDM F OFDM UFMC SEFDM FTN MUSA SCMA and NOMA Demonstrates the translation of signal processing theories into practical solutions for new spectrum opportunities in terms of millimeter wave full duplex transmission and license assisted access Presents well designed implementation examples from individual function block to system level for effective and accurate learning Covers signal processing aspects of emerging system and network architectures including ultra dense networks UDN software defined networks SDN device to device D2D communications and cloud radio access network C RAN

5G NR Sassan Ahmadi, 2019-06-18 *5G NR Architecture Technology Implementation and Operation of 3GPP New Radio Standards* is an in depth systematic technical reference on 3GPP s New Radio standards Release 15 and beyond covering the

underlying theory functional descriptions practical considerations and implementation of the 5G new radio access technology The book describes the design and operation of individual components and shows how they are integrated into the overall system and operate from a system s perspective Uniquely this book gives detailed information on RAN protocol layers transports network architectures and services as well as practical implementation and deployment issues making it suitable for researchers and engineers who are designing and developing 5G systems Reflecting on the author s 30 plus years of experience in signal processing microelectronics and wireless communication system design this book is ideal for professional engineers researchers and graduate students who are working and researching in cellular communication systems and protocols as well as mobile broadband wireless standards

Index Modulation for 5G Wireless

Communications Miaowen Wen,Xiang Cheng,Liuqing Yang,2016-12-23 This book presents a thorough examination of index modulation an emerging 5G modulation technique It includes representative transmitter and receiver design optimization and performance analysis of index modulation in various domains First the basic spatial modulation system for the spatial domain is introduced Then the development of a generalized pre coding aided quadrature spatial modulation system as well as a virtual spatial modulation system are presented For the space time domain a range of differential spatial modulation systems are examined along with the pre coding design Both basic and enhanced index modulated OFDM systems for the frequency domain are discussed focusing on the verification of their strong capabilities in inter carrier interference mitigation Finally key open problems are highlighted and future research directions are considered Designed for researchers and professionals this book is essential for anyone working in communications networking 5G and system design Advanced level students of engineering and computer science interested in efficiency techniques will also find the content valuable

An Introduction to 5G Wireless Networks Saro Velrajan,2020-07-01 An Introduction to 5G Wireless Networks book is for students engineers managers and for marketing sales executives to develop a good understanding of the 5G technology This book covers the 5G architecture 5G New Radio NR 5G Next Generation Core NG Core Network Slicing Virtualization of 5G Components Multi access Edge Computing MEC and the various 5G use cases This book provides details on the evolution of the wireless networks from 1G to 5G status of 5G deployments and the 5G marketplace standard bodies open source communities and vendors After reading this book you will be able to have discussions with customers interviewers and other stakeholders on the 5G concepts ecosystem and use cases

5G and Beyond Wireless Networks

Indrasen Singh,Shubham Tayal,Niraj Pratap Singh,Vijay Shanker Tripathi,Ghanshyam Singh,2024-02-26 5G and Beyond Wireless Networks Technology Network Deployments and Materials for Antenna Design offers a comprehensive overview of 5G and beyond 5G wireless networks along with emerging technologies that support the design and development of wireless networks It also includes discussions on various materials used for practical antenna design which are suitable for 5G beyond 5G applications and cell free massive MIMO systems The book discusses the latest techniques used in 5G and beyond 5G B5G

communication such as non orthogonal multiple access NOMA device to device D2D communication 6G ultra dense O RAN rate splitting multiple access RSMA simultaneous wireless information and power transfer SWIPT massive multiple input multiple output mMIMO and cell free massive MIMO systems which are explained in detail for 5G and beyond cellular networks The description of NOMA and their benefit for 5G and beyond networks is also addressed along with D2D communication for next generation cellular networks RSMA technique is also explained for 6G communication Detailed descriptions for the design and development of 5G and beyond networks over various techniques are included The materials specification to design antenna for 5G application are also given The role of metaleins in designing effective antennas and material specifications for 5G applications is explained in this book Apart from the above emerging topics this book also gives ideas about intelligent communication Internet of Multimedia Things IOMT millimeter wave MIMO UPMC and fog computing cloud networks The last chapter gives details about the legal frameworks for 5G technology for responsible and sustainable deployment Overall this book may benefit network design engineers and researchers working in the area of next generation cellular networks The contents of this book will be helpful for young researchers and master students and network design engineers who are working in the area of next generation cellular networks

5G System Design Wan Lei,Anthony C.K. Soong,Liu Jianghua,Wu Yong,Brian Classon,Weimin Xiao,David Mazzaresse,Zhao Yang,Tony Saboorian,2019-09-09 This book presents a detailed pedagogical description of the 5G commercial wireless communication system design from an end to end perspective It compares and contrasts NR with LTE and gives a concise and highly accessible description of the key technologies in the 5G physical layer radio access network layer protocols and procedures This book also illustrates how the 5G core and EPC is integrated into the radio access network how virtualization and edge computer fundamentally change the way users interact with the network as well as 5G spectrum issues This book is structured into six chapters The first chapter reviews the use cases requirements and standardization organization and activities for 5G These are 5G requirements and not NR specifically as technology that meets the requirements may be submitted to the ITU as 5G technology This includes a set of Radio Access Technologies RATs consisting of NR and LTE with each RAT meeting different aspects of the requirements The second chapter describes the air interface of NR and LTE side by side The basic aspects of LTE that NR builds upon are first described followed by sections on the NR specific technologies such as carrier channel spectrum duplexing including SUL LTE NR co existence and new physical layer technologies including waveform Polar LDPC codes MIMO and URLLC mMTC In all cases the enhancements made relative to LTE are made apparent The third chapter contains descriptions of NR procedures IAM Beam Management Power control HARQ protocols CP UP mobility including grant free and RAN architecture The fourth chapter includes a detailed discussion related to end to end system architecture and the 5G Core 5GC network slicing service continuity relation to EPC network virtualization and edge computing The fifth and major chapter describes the ITU submission and how NR and LTE meet the 5G requirements in significant detail from the

rapporteur responsible for leading the preparation and evaluation as well as some field trial results Engineers computer scientists and professionals with a passing knowledge of 4G LTE and a comprehensive understanding of the end to end 5G commercial wireless system will find this book to be a valuable asset Advanced level students and researchers studying and working in communication engineering who want to gain an understanding of the 5G system as well as methodologies to evaluate features and technologies intended to supplement 5G will also find this book to be a valuable resource

This is likewise one of the factors by obtaining the soft documents of this **5g Wireless Technology Development Matlab Simulink** by online. You might not require more epoch to spend to go to the book launch as competently as search for them. In some cases, you likewise accomplish not discover the pronouncement 5g Wireless Technology Development Matlab Simulink that you are looking for. It will completely squander the time.

However below, in imitation of you visit this web page, it will be suitably completely easy to acquire as capably as download guide 5g Wireless Technology Development Matlab Simulink

It will not undertake many era as we accustom before. You can do it even if perform something else at house and even in your workplace. correspondingly easy! So, are you question? Just exercise just what we have enough money under as skillfully as evaluation **5g Wireless Technology Development Matlab Simulink** what you next to read!

https://py.bijouxmedusa.com/files/browse/index.jsp/29_849_nft_marketplace_apps_for_creators_29_1985_nft_marketplace_ap ps.pdf

Table of Contents 5g Wireless Technology Development Matlab Simulink

1. Understanding the eBook 5g Wireless Technology Development Matlab Simulink
 - The Rise of Digital Reading 5g Wireless Technology Development Matlab Simulink
 - Advantages of eBooks Over Traditional Books
2. Identifying 5g Wireless Technology Development Matlab Simulink
 - Exploring Different Genres
 - Considering Fiction vs. Non-Fiction
 - Determining Your Reading Goals
3. Choosing the Right eBook Platform
 - Popular eBook Platforms
 - Features to Look for in an 5g Wireless Technology Development Matlab Simulink
 - User-Friendly Interface

4. Exploring eBook Recommendations from 5g Wireless Technology Development Matlab Simulink
 - Personalized Recommendations
 - 5g Wireless Technology Development Matlab Simulink User Reviews and Ratings
 - 5g Wireless Technology Development Matlab Simulink and Bestseller Lists
5. Accessing 5g Wireless Technology Development Matlab Simulink Free and Paid eBooks
 - 5g Wireless Technology Development Matlab Simulink Public Domain eBooks
 - 5g Wireless Technology Development Matlab Simulink eBook Subscription Services
 - 5g Wireless Technology Development Matlab Simulink Budget-Friendly Options
6. Navigating 5g Wireless Technology Development Matlab Simulink eBook Formats
 - ePub, PDF, MOBI, and More
 - 5g Wireless Technology Development Matlab Simulink Compatibility with Devices
 - 5g Wireless Technology Development Matlab Simulink Enhanced eBook Features
7. Enhancing Your Reading Experience
 - Adjustable Fonts and Text Sizes of 5g Wireless Technology Development Matlab Simulink
 - Highlighting and Note-Taking 5g Wireless Technology Development Matlab Simulink
 - Interactive Elements 5g Wireless Technology Development Matlab Simulink
8. Staying Engaged with 5g Wireless Technology Development Matlab Simulink
 - Joining Online Reading Communities
 - Participating in Virtual Book Clubs
 - Following Authors and Publishers 5g Wireless Technology Development Matlab Simulink
9. Balancing eBooks and Physical Books 5g Wireless Technology Development Matlab Simulink
 - Benefits of a Digital Library
 - Creating a Diverse Reading Collection 5g Wireless Technology Development Matlab Simulink
10. Overcoming Reading Challenges
 - Dealing with Digital Eye Strain
 - Minimizing Distractions
 - Managing Screen Time
11. Cultivating a Reading Routine 5g Wireless Technology Development Matlab Simulink
 - Setting Reading Goals 5g Wireless Technology Development Matlab Simulink
 - Carving Out Dedicated Reading Time

12. Sourcing Reliable Information of 5g Wireless Technology Development Matlab Simulink
 - Fact-Checking eBook Content of 5g Wireless Technology Development Matlab Simulink
 - Distinguishing Credible Sources
13. Promoting Lifelong Learning
 - Utilizing eBooks for Skill Development
 - Exploring Educational eBooks
14. Embracing eBook Trends
 - Integration of Multimedia Elements
 - Interactive and Gamified eBooks

5g Wireless Technology Development Matlab Simulink Introduction

5g Wireless Technology Development Matlab Simulink Offers over 60,000 free eBooks, including many classics that are in the public domain. Open Library: Provides access to over 1 million free eBooks, including classic literature and contemporary works. 5g Wireless Technology Development Matlab Simulink Offers a vast collection of books, some of which are available for free as PDF downloads, particularly older books in the public domain. 5g Wireless Technology Development Matlab Simulink : This website hosts a vast collection of scientific articles, books, and textbooks. While it operates in a legal gray area due to copyright issues, its a popular resource for finding various publications. Internet Archive for 5g Wireless Technology Development Matlab Simulink : Has an extensive collection of digital content, including books, articles, videos, and more. It has a massive library of free downloadable books. Free-eBooks 5g Wireless Technology Development Matlab Simulink Offers a diverse range of free eBooks across various genres. 5g Wireless Technology Development Matlab Simulink Focuses mainly on educational books, textbooks, and business books. It offers free PDF downloads for educational purposes. 5g Wireless Technology Development Matlab Simulink Provides a large selection of free eBooks in different genres, which are available for download in various formats, including PDF. Finding specific 5g Wireless Technology Development Matlab Simulink, especially related to 5g Wireless Technology Development Matlab Simulink, might be challenging as theyre often artistic creations rather than practical blueprints. However, you can explore the following steps to search for or create your own Online Searches: Look for websites, forums, or blogs dedicated to 5g Wireless Technology Development Matlab Simulink, Sometimes enthusiasts share their designs or concepts in PDF format. Books and Magazines Some 5g Wireless Technology Development Matlab Simulink books or magazines might include. Look for these in online stores or libraries. Remember that while 5g Wireless Technology Development Matlab Simulink, sharing copyrighted material without permission is not legal. Always ensure youre either creating your own or obtaining them from legitimate sources that allow

sharing and downloading. Library Check if your local library offers eBook lending services. Many libraries have digital catalogs where you can borrow 5g Wireless Technology Development Matlab Simulink eBooks for free, including popular titles. Online Retailers: Websites like Amazon, Google Books, or Apple Books often sell eBooks. Sometimes, authors or publishers offer promotions or free periods for certain books. Authors Website Occasionally, authors provide excerpts or short stories for free on their websites. While this might not be the 5g Wireless Technology Development Matlab Simulink full book, it can give you a taste of the authors writing style. Subscription Services Platforms like Kindle Unlimited or Scribd offer subscription-based access to a wide range of 5g Wireless Technology Development Matlab Simulink eBooks, including some popular titles.

FAQs About 5g Wireless Technology Development Matlab Simulink Books

How do I know which eBook platform is the best for me? Finding the best eBook platform depends on your reading preferences and device compatibility. Research different platforms, read user reviews, and explore their features before making a choice. Are free eBooks of good quality? Yes, many reputable platforms offer high-quality free eBooks, including classics and public domain works. However, make sure to verify the source to ensure the eBook credibility. Can I read eBooks without an eReader? Absolutely! Most eBook platforms offer webbased readers or mobile apps that allow you to read eBooks on your computer, tablet, or smartphone. How do I avoid digital eye strain while reading eBooks? To prevent digital eye strain, take regular breaks, adjust the font size and background color, and ensure proper lighting while reading eBooks. What the advantage of interactive eBooks? Interactive eBooks incorporate multimedia elements, quizzes, and activities, enhancing the reader engagement and providing a more immersive learning experience. 5g Wireless Technology Development Matlab Simulink is one of the best book in our library for free trial. We provide copy of 5g Wireless Technology Development Matlab Simulink in digital format, so the resources that you find are reliable. There are also many Ebooks of related with 5g Wireless Technology Development Matlab Simulink. Where to download 5g Wireless Technology Development Matlab Simulink online for free? Are you looking for 5g Wireless Technology Development Matlab Simulink PDF? This is definitely going to save you time and cash in something you should think about. If you trying to find then search around for online. Without a doubt there are numerous these available and many of them have the freedom. However without doubt you receive whatever you purchase. An alternate way to get ideas is always to check another 5g Wireless Technology Development Matlab Simulink. This method for see exactly what may be included and adopt these ideas to your book. This site will almost certainly help you save time and effort, money and stress. If you are looking for free books then you really should consider finding to assist you try this. Several of 5g Wireless Technology Development Matlab Simulink are for sale to

free while some are payable. If you arent sure if the books you would like to download works with for usage along with your computer, it is possible to download free trials. The free guides make it easy for someone to free access online library for download books to your device. You can get free download on free trial for lots of books categories. Our library is the biggest of these that have literally hundreds of thousands of different products categories represented. You will also see that there are specific sites catered to different product types or categories, brands or niches related with 5g Wireless Technology Development Matlab Simulink. So depending on what exactly you are searching, you will be able to choose e books to suit your own need. Need to access completely for Campbell Biology Seventh Edition book? Access Ebook without any digging. And by having access to our ebook online or by storing it on your computer, you have convenient answers with 5g Wireless Technology Development Matlab Simulink To get started finding 5g Wireless Technology Development Matlab Simulink, you are right to find our website which has a comprehensive collection of books online. Our library is the biggest of these that have literally hundreds of thousands of different products represented. You will also see that there are specific sites catered to different categories or niches related with 5g Wireless Technology Development Matlab Simulink So depending on what exactly you are searching, you will be able to choose ebook to suit your own need. Thank you for reading 5g Wireless Technology Development Matlab Simulink. Maybe you have knowledge that, people have search numerous times for their favorite readings like this 5g Wireless Technology Development Matlab Simulink, but end up in harmful downloads. Rather than reading a good book with a cup of coffee in the afternoon, instead they juggled with some harmful bugs inside their laptop. 5g Wireless Technology Development Matlab Simulink is available in our book collection an online access to it is set as public so you can download it instantly. Our digital library spans in multiple locations, allowing you to get the most less latency time to download any of our books like this one. Merely said, 5g Wireless Technology Development Matlab Simulink is universally compatible with any devices to read.

Find 5g Wireless Technology Development Matlab Simulink :

29-849 NFT marketplace apps for creators 29-1985 NFT marketplace apps

work checklist USA 29-414 remote work checklist for creators 29-453

development trends for startups 29-786 blockchain development tutorial

business automation ideas America 29-1890 business automation ideas for

29-1837 small business ideas checklist USA 29-846 small business ideas

machine learning basics step by step USA 29-782 machine learning basics

creators 29-1679 healthy recipes roadmap for entrepreneurs 29-2564

entrepreneurs 29-1847 blockchain development comparison for

USA 29-1871 career growth tips for small business 29-2983 career growth development trends America 29-993 blockchain development trends United vehicles apps USA 29-148 electric vehicles apps for entrepreneurs 29-820 ideas software United States 29-2043 mobile app ideas software for startups 29-2531 mobile app ideas step by step America 29-2257 mobile United States 29-2846 YouTube growth tips for creators 29-2172 YouTube America 29-1135 home organization roadmap USA 29-998 home organization

5g Wireless Technology Development Matlab Simulink :

Australian National Curriculum Checklists For Progression Points Knowledge at the Crossroads? Australian Bird Names. Teaching for Numeracy Across the Age Range. Australian Curriculum English. K-2 Number Activities. Australian curriculum checklist This bundle of editable Australian Curriculum Assessment Checklists for Year 3 will make your planning and assessment simple and ... National Literacy and Numeracy Learning Progressions In the Australian Curriculum, learning area content describes the knowledge, understanding and skills that are to be taught in each year or band of years. National Literacy Learning Progression The progression has not been designed as a checklist and does not replace the Australian Curriculum: English. Each sub-element has been mapped to the year level ... Australian Curriculum Mathematics Assessment Checklists ... Progression Point by the end of the term/year. Each checklist is broken up into the ACARA Australian Curriculum Mathematics Content Strands and Sub Strands ... Australian curriculum assessment checklist ... assessment checklist linked to AusVELs progression points for reading and viewing. Subjects: Reading. Grades: 2nd - 6th. Types: Assessment. Year 4 Maths National Curriculum Assessment Checklist Track pupil knowledge against the Maths National Curriculum for year 4 with this handy checklist, which includes Ready-to-Progress criteria on a separate ... National Literacy Learning Progression The progression amplifies the literacy skills in the. Australian Curriculum: English, particularly in the Language and Literacy strands, and is organised by ... Australian Curriculum Mathematics Assessment Checklists Australian Curriculum ~ Australian Assessment: These Australian Curriculum Mathematics Checklists are designed to make your assessment A LOT easier! Pages - Literacy learning progressions The need to develop national Literacy and Numeracy Progressions was identified by all Australian education ministers in December 2015. The Australian Curriculum ... 1. AB Calculus - Step-by-Step Name Write, but do not solve, an equation involving an integral expression whose solution k would be the number of days the height of the snow would be half of its ... Step by Step Student Let f be a twice-differentiable function defined on the interval. $0.5 < x < 4.5$ with $f(2) = 3$. The graph of f, the derivative of f is shown to the right. 70. AB Calculus - Step-by-Step Name Stu Schwartz. 70. AB Calculus - Step-by-Step. Name ... Describe the region in the xy-plane in

which all the solutions to the differential equation are concave ... ABReview Stu Schwartz AB Calculus Exam - Review Sheet - Solutions. A. Precalculus Type problems ... $f(x)$. Step 1: Find $f'(a)$. If you get a zero in the denominator, . Step 2 ... Diff EQ Practice.pdf - 70. AB Calculus - Step-by-Step Name View Diff_EQ_Practice.pdf from MATH 1300 at Brooklyn College, CUNY. 70. AB Calculus - Step-by-Step Name _ Consider the differential equation $dy/dx + 1 = y$... AB Calculus Manual (Revised 12/2019) This manual can easily replace an expensive textbook. Teachers teach right from it and students write in it. The Solution Manual is exactly the same as the ... AB Calculus - Step-by-Step - 24. Function Analysis There is a relative maximum at $x=2$ as f' switches from positive to negative. b. On what intervals is the graph of f concave upward? Justify your answers. (2). img-X26071655-0001 - 24. AB Calculus Step-by- ... View img-X26071655-0001 from MATH 2215 at Cameron University. 24. AB Calculus Step-by-Step Name The figure to the right shows the graph of f , the derivative ... MasterMathMentor AB31 - Definite Integrals with u-Substitution MMM AB Calculus MasterMath Mentor AB0102 - Intro to Calculus / Tangent line problem. Stu Schwartz · 28:56. MasterMathMentor AB03 - Rates of Change. Top Level > Texts > Men's Magazines: 1970s and Beyond Magazines (1) Men's Magazine (55) Men's Magazines (1,148) Men's Magazines, Erotic, Adult, Magazine, British Magazine (7) Men's Magazines, Erotic, Adult, ... Men are lost. Here's a map out of the wilderness. Young men who disappear into online forums, video games or pornography see none of the social or personal rewards of meeting these goals ... The TIME Magazine Vault Check out the online archives of TIME Magazine: complete coverage since 1923 of world news, politics, entertainment, science, health, history, business and ... BRIDGING THE DIGITAL GENDER DIVIDE Recognising that gender equality is essential for ensuring that men and women can contribute fully for the betterment of societies and economies at large, G20 ... GQ: Men's Fashion, Style, Grooming, Fitness, Lifestyle, News ... The latest tips and advice for men on style, grooming, fitness, best products, travel destinations and more. Find politics, sports and entertainment news. Wikipedia:List of online newspaper archives This is a list of online newspaper archives and some magazines and journals, including both free and pay wall blocked digital archives. PLOS ONE Correction: Clinical efficacy and safety of interferon (Type I and Type III) therapy in patients with COVID-19: A systematic review and meta-analysis of ... The New Yorker Reporting, Profiles, breaking news, cultural coverage, podcasts, videos, and cartoons from The New Yorker. New York Magazine New York Magazine obsessively chronicles the ideas, people, and cultural events that are forever reshaping our world. The BMJ: Leading Medical Research, News, Education, Opinion High impact medical journal. Champion of better research, clinical practice & healthcare policy since 1840. For GPs, hospital doctors, educators, ...