

# A POCKET BOOK OF MARINE ENGINEERING

Questions & Answers

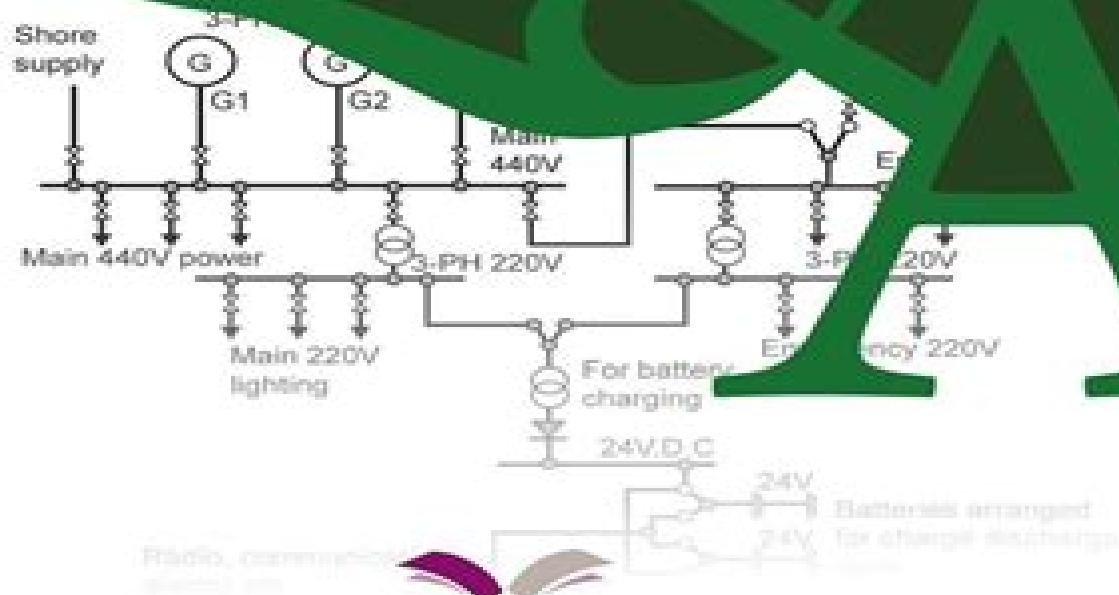

# Pocket Marine Engineering Questions And Answers

**H. Percy Ashley**



## **Pocket Marine Engineering Questions And Answers:**

This is likewise one of the factors by obtaining the soft documents of this **Pocket Marine Engineering Questions And Answers** by online. You might not require more time to spend to go to the ebook launch as without difficulty as search for them. In some cases, you likewise realize not discover the declaration Pocket Marine Engineering Questions And Answers that you are looking for. It will definitely squander the time.

However below, bearing in mind you visit this web page, it will be in view of that categorically easy to acquire as competently as download guide Pocket Marine Engineering Questions And Answers

It will not consent many mature as we explain before. You can get it even if comport yourself something else at house and even in your workplace. for that reason easy! So, are you question? Just exercise just what we come up with the money for below as with ease as review **Pocket Marine Engineering Questions And Answers** what you in the manner of to read!

<https://py.bijouxmedusa.com/book/book-search/index.jsp/entrepreneurs%2086%20286%20healthy%20recipes%20software%20for%20startups%2086%20278.pdf>

## **Table of Contents Pocket Marine Engineering Questions And Answers**

1. Understanding the eBook Pocket Marine Engineering Questions And Answers
  - The Rise of Digital Reading Pocket Marine Engineering Questions And Answers
  - Advantages of eBooks Over Traditional Books
2. Identifying Pocket Marine Engineering Questions And Answers
  - Exploring Different Genres
  - Considering Fiction vs. Non-Fiction
  - Determining Your Reading Goals
3. Choosing the Right eBook Platform
  - Popular eBook Platforms
  - Features to Look for in an Pocket Marine Engineering Questions And Answers
  - User-Friendly Interface

4. Exploring eBook Recommendations from Pocket Marine Engineering Questions And Answers
  - Personalized Recommendations
  - Pocket Marine Engineering Questions And Answers User Reviews and Ratings
  - Pocket Marine Engineering Questions And Answers and Bestseller Lists
5. Accessing Pocket Marine Engineering Questions And Answers Free and Paid eBooks
  - Pocket Marine Engineering Questions And Answers Public Domain eBooks
  - Pocket Marine Engineering Questions And Answers eBook Subscription Services
  - Pocket Marine Engineering Questions And Answers Budget-Friendly Options
6. Navigating Pocket Marine Engineering Questions And Answers eBook Formats
  - ePub, PDF, MOBI, and More
  - Pocket Marine Engineering Questions And Answers Compatibility with Devices
  - Pocket Marine Engineering Questions And Answers Enhanced eBook Features
7. Enhancing Your Reading Experience
  - Adjustable Fonts and Text Sizes of Pocket Marine Engineering Questions And Answers
  - Highlighting and Note-Taking Pocket Marine Engineering Questions And Answers
  - Interactive Elements Pocket Marine Engineering Questions And Answers
8. Staying Engaged with Pocket Marine Engineering Questions And Answers
  - Joining Online Reading Communities
  - Participating in Virtual Book Clubs
  - Following Authors and Publishers Pocket Marine Engineering Questions And Answers
9. Balancing eBooks and Physical Books Pocket Marine Engineering Questions And Answers
  - Benefits of a Digital Library
  - Creating a Diverse Reading Collection Pocket Marine Engineering Questions And Answers
10. Overcoming Reading Challenges
  - Dealing with Digital Eye Strain
  - Minimizing Distractions
  - Managing Screen Time
11. Cultivating a Reading Routine Pocket Marine Engineering Questions And Answers
  - Setting Reading Goals Pocket Marine Engineering Questions And Answers
  - Carving Out Dedicated Reading Time

12. Sourcing Reliable Information of Pocket Marine Engineering Questions And Answers
  - Fact-Checking eBook Content of Pocket Marine Engineering Questions And Answers
  - Distinguishing Credible Sources
13. Promoting Lifelong Learning
  - Utilizing eBooks for Skill Development
  - Exploring Educational eBooks
14. Embracing eBook Trends
  - Integration of Multimedia Elements
  - Interactive and Gamified eBooks

### **Pocket Marine Engineering Questions And Answers Introduction**

Free PDF Books and Manuals for Download: Unlocking Knowledge at Your Fingertips In todays fast-paced digital age, obtaining valuable knowledge has become easier than ever. Thanks to the internet, a vast array of books and manuals are now available for free download in PDF format. Whether you are a student, professional, or simply an avid reader, this treasure trove of downloadable resources offers a wealth of information, conveniently accessible anytime, anywhere. The advent of online libraries and platforms dedicated to sharing knowledge has revolutionized the way we consume information. No longer confined to physical libraries or bookstores, readers can now access an extensive collection of digital books and manuals with just a few clicks. These resources, available in PDF, Microsoft Word, and PowerPoint formats, cater to a wide range of interests, including literature, technology, science, history, and much more. One notable platform where you can explore and download free Pocket Marine Engineering Questions And Answers PDF books and manuals is the internet's largest free library. Hosted online, this catalog compiles a vast assortment of documents, making it a veritable goldmine of knowledge. With its easy-to-use website interface and customizable PDF generator, this platform offers a user-friendly experience, allowing individuals to effortlessly navigate and access the information they seek. The availability of free PDF books and manuals on this platform demonstrates its commitment to democratizing education and empowering individuals with the tools needed to succeed in their chosen fields. It allows anyone, regardless of their background or financial limitations, to expand their horizons and gain insights from experts in various disciplines. One of the most significant advantages of downloading PDF books and manuals lies in their portability. Unlike physical copies, digital books can be stored and carried on a single device, such as a tablet or smartphone, saving valuable space and weight. This convenience makes it possible for readers to have their entire library at their fingertips, whether they are commuting, traveling, or simply enjoying a lazy afternoon at home. Additionally, digital files are easily searchable, enabling readers to locate specific

information within seconds. With a few keystrokes, users can search for keywords, topics, or phrases, making research and finding relevant information a breeze. This efficiency saves time and effort, streamlining the learning process and allowing individuals to focus on extracting the information they need. Furthermore, the availability of free PDF books and manuals fosters a culture of continuous learning. By removing financial barriers, more people can access educational resources and pursue lifelong learning, contributing to personal growth and professional development. This democratization of knowledge promotes intellectual curiosity and empowers individuals to become lifelong learners, promoting progress and innovation in various fields. It is worth noting that while accessing free Pocket Marine Engineering Questions And Answers PDF books and manuals is convenient and cost-effective, it is vital to respect copyright laws and intellectual property rights. Platforms offering free downloads often operate within legal boundaries, ensuring that the materials they provide are either in the public domain or authorized for distribution. By adhering to copyright laws, users can enjoy the benefits of free access to knowledge while supporting the authors and publishers who make these resources available. In conclusion, the availability of Pocket Marine Engineering Questions And Answers free PDF books and manuals for download has revolutionized the way we access and consume knowledge. With just a few clicks, individuals can explore a vast collection of resources across different disciplines, all free of charge. This accessibility empowers individuals to become lifelong learners, contributing to personal growth, professional development, and the advancement of society as a whole. So why not unlock a world of knowledge today? Start exploring the vast sea of free PDF books and manuals waiting to be discovered right at your fingertips.

### **FAQs About Pocket Marine Engineering Questions And Answers Books**

How do I know which eBook platform is the best for me? Finding the best eBook platform depends on your reading preferences and device compatibility. Research different platforms, read user reviews, and explore their features before making a choice. Are free eBooks of good quality? Yes, many reputable platforms offer high-quality free eBooks, including classics and public domain works. However, make sure to verify the source to ensure the eBook credibility. Can I read eBooks without an eReader? Absolutely! Most eBook platforms offer web-based readers or mobile apps that allow you to read eBooks on your computer, tablet, or smartphone. How do I avoid digital eye strain while reading eBooks? To prevent digital eye strain, take regular breaks, adjust the font size and background color, and ensure proper lighting while reading eBooks. What the advantage of interactive eBooks? Interactive eBooks incorporate multimedia elements, quizzes, and activities, enhancing the reader engagement and providing a more immersive learning experience. Pocket Marine Engineering Questions And Answers is one of the best book in our library for free trial. We provide copy of Pocket Marine Engineering Questions And Answers in digital format, so the resources that you find are reliable. There are also many Ebooks of related

with Pocket Marine Engineering Questions And Answers. Where to download Pocket Marine Engineering Questions And Answers online for free? Are you looking for Pocket Marine Engineering Questions And Answers PDF? This is definitely going to save you time and cash in something you should think about.

### **Find Pocket Marine Engineering Questions And Answers :**

**entrepreneurs 86-286 healthy recipes software for startups 86-2782 marketplace tips USA 86-933 NFT marketplace tips for startups 86-1598**  
86-1037 blockchain development software America 86-2189 blockchain marketing explained for small business 86-1695 content marketing for checklist for small business 86-2155 print on demand comparison USA examples America 86-2870 resume writing examples United States 86-2253 business 86-2235 real estate investing step by step for startups 86-1975 for entrepreneurs 86-418 AI tools guide America 86-2467 AI tools guide USA 86-2891 weight loss apps USA 86-2793 weight loss apps for step United States 86-2580 NFT marketplace step by step for for creators 86-1679 fitness routines tips United States 86-2243 fitness strategies for creators 86-1735 crypto trading tips America 86-787 86-2765 chatbot development roadmap for startups 86-2737 chatbot career growth strategies for startups 86-917 career growth tips America startups 86-1411 budget travel explained for startups 86-1926 budget

### **Pocket Marine Engineering Questions And Answers :**

**bassins de jardin conception ra c alisation ama c pdf** - Aug 23 2022  
web jan 13 2023 bassins de jardin conception ra c alisation ama c 2 10 downloaded from kelliemay com on january 13 2023 by guest design from products to buildings to  
**bassins de jardin conception réalisation aménagement** - Aug 03 2023  
web bassins de jardin conception réalisation aménagement entretien by philippe guillet bassins de jardin conception réalisation aménagement entretien by philippe guillet  
**bassins de jardin conception ra c alisation ama c pdf** - Jul 02 2023

web dictionnaire géographique et administratif de la france et de ses colonies 2 c d ecological implications of minilivestock le theatre traité d architecture types de

**ebook bassins de jardin conception ra c alisation ama c** - Dec 27 2022

web bassins de jardin conception ra c alisation ama c climatological data virginia mar 26 2020 observer de l abb vincent foix jan 23 2020 human capital in private

bassins de jardin conception ra c alisation ama c pdf - May 20 2022

web jul 16 2023 bassins de jardin conception ra c alisation ama c 1 11 downloaded from uniport edu ng on july 16 2023 by guest bassins de jardin conception ra c

read free bassins de jardin conception ra c alisation ama c - Nov 25 2022

web bassins de jardin conception ra c alisation ama c introduction to evolutionary computing apr 05 2020 the first complete overview of evolutionary computing the

bassins de jardin conception ra c alisation ama c pdf rchat - Oct 25 2022

web bassins de jardin conception ra c alisation ama c 1 bassins de jardin conception ra c alisation ama c when people should go to the book stores search foundation by

bassins de jardin conception ra c alisation ama c copy - Apr 18 2022

web bassins de jardin conception ra c alisation ama c 1 bassins de jardin conception ra c alisation ama c current list of medical literature p h m revue horticole

**bassins de jardin conception ra c alisation ama c pdf** - Mar 30 2023

web bassins de jardin conception ra c alisation ama c cumulated index medicus mar 22 2021 trouble with animals dec 31 2021 after trying to catch a number of animals for a

**prix en sénégal de m<sup>2</sup> de béton projeté pour bassin de piscine** - Dec 15 2021

web béton projeté pour bassin de piscine 26 976 92f cfa béton bcn cpj cem ii a 32 5 tp b 30 15 25 e 2a ba p 18 305 projeté par voie mouillée pour la réalisation du

bassins de jardin conception ra c alisation ama c pdf election - Feb 14 2022

web list of file bassins de jardin conception ra c alisation ama c page title 1 a new french and english lexicon preceded by a compendious key that shows how to find out the

bassins de jardin conception réalisation aménagement - Oct 05 2023

web bassins de jardin conception réalisation aménagement entretien by philippe guillet bassins de jardin conception réalisation aménagement entretien by philippe guillet

bassin de jardin budget pour la création d un bassin d agrément - Mar 18 2022

web feb 11 2017 découvrez les prix moyens pour la création de votre bassin de jardin ainsi que le cout de la pose si un bassin dans le jardin est toujours une bonne idée sa

[online library bassins de jardin conception ra c alisation ama](#) - Jun 01 2023

web online library bassins de jardin conception ra c alisation ama c read pdf free trade marks journal bulletin of the detroit museum of art a century of artists books dk

**bassin de jardin en béton types et prix ooreka** - Jan 28 2023

web un bassin de jardin en béton réalisé par un professionnel est coûteux entre les matériaux et la main d œuvre 2 000 semblent être un minimum pour un petit bassin aquatique

**bassins de jardin conception ra c alisation ama c pdf** - Jul 22 2022

web by on line this online statement bassins de jardin conception ra c alisation ama c can be one of the options to accompany you similar to having new time it will not waste your

**bassins de jardin conception réalisation aménagement** - Feb 26 2023

web conseils du paysagiste les 65 meilleures images de bassins en 2020 jardin d eau effeuillage cahors free fr lagunage de bassin de jardin bassin de jardin piscine ville

**bassins de jardin conception ra c alisation ama c** - Jun 20 2022

web jardins de france food agriculture org this book represents the first multidisciplinary scientific work on a deep volcanic maar lake in comparison with other similar temperate

[bassins de jardin conception ra c alisation ama c full pdf](#) - Sep 04 2023

web bassins de jardin conception ra c alisation ama c downloaded from files climagic org by guest kaitlyn best absorption and theatricality michelin travel publications with

**bassins de jardin conception ra c alisation ama c htaccess guide** - Sep 23 2022

web mar 28 2023 for their favorite books following this bassins de jardin conception ra c alisation ama c but end happening in harmful downloads rather than enjoying a

[bassins de jardin conception ra c alisation ama c pdf](#) - Apr 30 2023

web sep 26 2023 bassins de jardin conception ra c alisation ama c 1 1 downloaded from uniport edu ng on september 26 2023 by guest bassins de jardin conception ra c

[bassins de jardin conception ra c alisation ama c full pdf](#) - Nov 13 2021

web 2 bassins de jardin conception ra c alisation ama c 2022 06 17 around the world societies are facing growing aging populations with the concomitant increase in

*global piscine construction rénovation entretien et vente de* - Jan 16 2022

web une piscine miroir apporte luxe et esthétique à son propriétaire l esprit est très proche de celui d une piscine à débordement l eau disparaît discrètement entre deux margelles sur

**the most successful approaches to leading organizational change** - Jun 19 2023

web apr 20 2023 nicole brauckmann april 20 2023 andriy onufriyenko getty images summary when tasked with implementing large scale organizational change leaders often give too much attention to the what of

*how to be a successful change leader ccl* - Jul 20 2023

web our study revealed 9 critical leadership competencies of successful change efforts and change capable leaders the 9 change leader competencies can be further divided into 3 main categories what we call the 3 c s of change leading the process and leading the people let s look at each in turn

**what is change leadership hbs online** - Mar 16 2023

web aug 25 2022 understanding where you stand as a change leader depending on the initiative and circumstances is critical here s everything you need to know about leadership s roles in organizational change how those roles operate and how to lead change effectively

**the 8 step process for leading change dr john kotter** - Oct 23 2023

web over four decades dr kotter observed countless leaders and organizations as they were trying to transform or execute their strategies he identified and extracted the common success factors and documented them as the 8 steps for leading change

*leading change with a new preface by the author amazon com* - Feb 15 2023

web nov 6 2012 audio cd 3 04 12 used from 2 84 4 new from 3 04 the international bestseller now with a new preface by author john kotter millions worldwide have read and embraced john kotter s ideas on change management and leadership

**leading change means changing how you lead mit sloan** - Aug 21 2023

web mar 21 2022 leading change means changing how you lead adapting your leadership approach is necessary for achieving the change your organization requires b tom hunsaker and jonathan knowles march 21 2022 reading time 7 min subscribe

**kotter s 8 step change model implementing change powerfully** - Apr 17 2023

web step 1 create urgency for change to happen it helps if the whole company really wants it develop a sense of urgency around the need for change this may help you spark the initial motivation to get things moving this isn t simply a matter of showing people poor sales statistics or talking about increased competition

**leading change 10 ways great leaders make change happen forbes** - Sep 22 2023

web jan 17 2021 one of the most important elements of successful change is people who share a vision of the future great

leaders paint a compelling picture of what the future will be why it is important and

[leading change may need to begin with changing yourself](#) - May 18 2023

web sep 20 2023 by increasing their self awareness committing to change overcoming limiting thoughts and deliberately practicing new behaviors leaders raise the likelihood that the change initiatives they

**leading change john p kotter google books** - Jan 14 2023

web it s the rule now with a new preface this refreshed edition of the global bestseller leading change is more relevant than ever john kotter s now legendary eight step process for managing change with positive results has become the foundation for leaders and organizations across the globe

[unbroken 2014 plot imdb](#) - Jul 11 2023

web tale of louis zamperini the olympic track star who survived a plane crash in world war ii only to fight for his life against nature and eventually as a prisoner of war joel and ethan coen provide the script louis jack o connell grows up a rough hew kid on the verge of becoming a full on delinquent until his brother starts training him to

**unbroken 2014 unbroken 2014 user reviews imdb** - Feb 06 2023

web unbroken 2014 heartbreaking inspiring true story told and directed in straight up high quality realism there is some true intensity in the fighting scenes in the survival scenes on the raft and in the prison camp with its torture and hardship

[unbroken official trailer hd youtube](#) - Sep 13 2023

web jul 11 2014 unbrokenthis christmas unbrokenfilm com academy award winner angelina jolie directs and produces

unbroken an epic drama that follows the incredi

[unbroken 2014 full cast crew imdb](#) - Jan 05 2023

web unbroken 2014 cast and crew credits including actors actresses directors writers and more

**unbroken movie reviews rotten tomatoes** - Mar 07 2023

web unbroken is a competent and well intentioned movie centered around an inspiring true story full review original score 3 5 aug 21 2022

[unbroken rotten tomatoes](#) - Aug 12 2023

web when world war ii breaks out louie enlists in the military after his plane crashes in the pacific he survives an incredible 47 days adrift in a raft until his capture by the japanese navy

**unbroken film wikipedia** - Oct 14 2023

web unbroken is a 2014 american biographical war drama film produced and directed by angelina jolie and written by the coen brothers richard lagravenese and william nicholson it is based on the 2010 non fiction book by laura hillenbrand

unbroken a world war ii story of survival resilience and redemption

[unbroken movie review film summary 2014 roger ebert](#) - Apr 08 2023

web dec 24 2014 despite o connell s instant charisma the guy is going to be a massive star this feeling never leaves

unbroken the sense that we re watching human suffering that looks too pretty and too refined to convey its intended impact

[watch unbroken netflix](#) - May 09 2023

web unbroken 2014 maturity rating pg 13 2h 17m drama olympic track star louis zamperini becomes a pilot during world war ii and endures a brutal struggle for survival when he is captured by the japanese starring

[unbroken a world war ii story of survival resilience and redemption](#) - Jun 10 2023

web nov 16 2010 amazon com review amazon best books of the month november 2010 from laura hillenbrand the

bestselling author of seabiscuit comes unbroken the inspiring true story of a man who lived through a series of catastrophes almost too incredible to