

Knife path

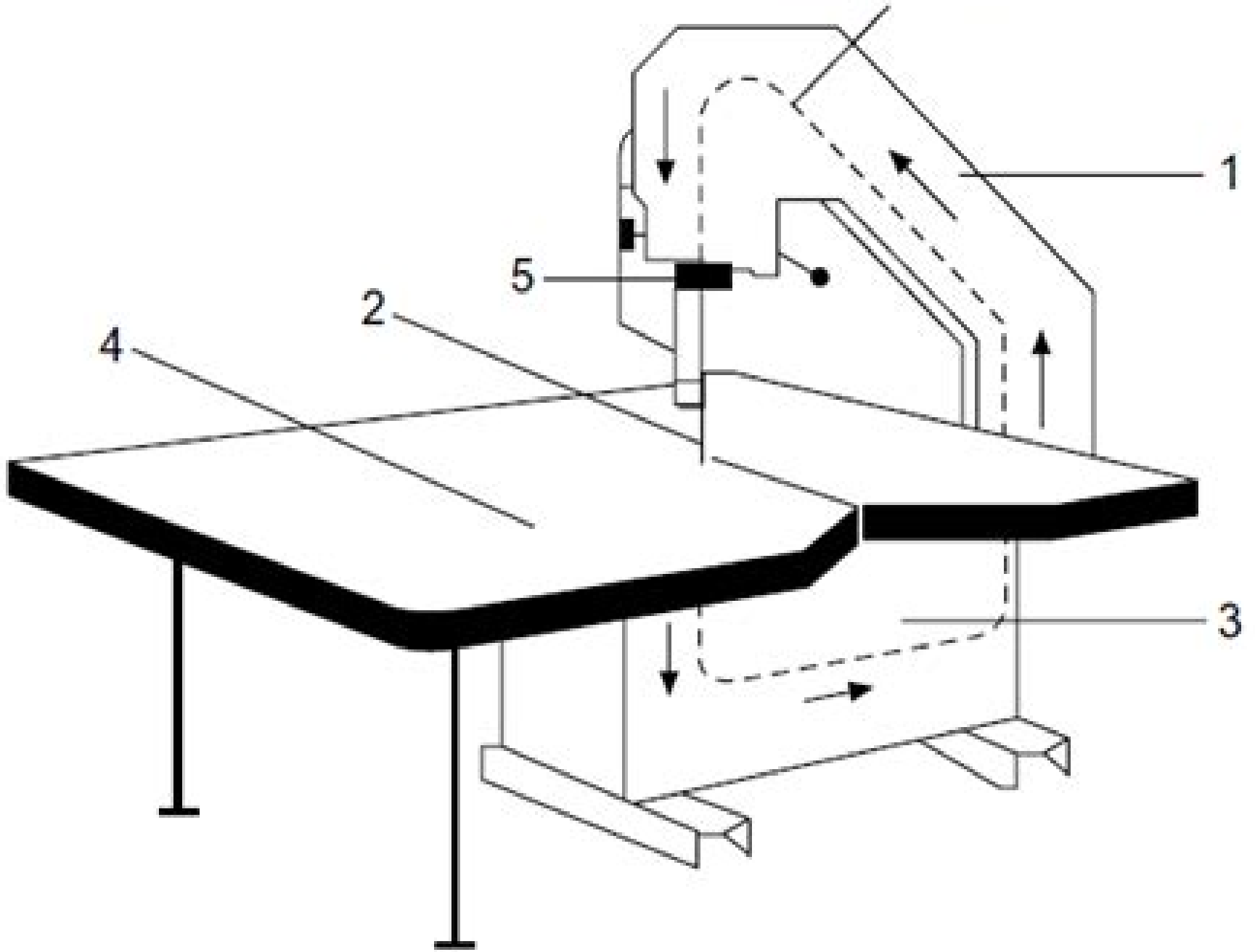

Band Knife Machine Manual

David Baud



Band Knife Machine Manual:

Embark on a breathtaking journey through nature and adventure with Crafted by is mesmerizing ebook, Witness the Wonders in **Band Knife Machine Manual** . This immersive experience, available for download in a PDF format (PDF Size: *), transports you to the heart of natural marvels and thrilling escapades. Download now and let the adventure begin!

https://py.bijouxmedusa.com/results/detail/Documents/Tools_USA_16_2017_Passive_Income_Ideas_Tools_For_Creators_16_23_3_Passive.pdf

Table of Contents Band Knife Machine Manual

1. Understanding the eBook Band Knife Machine Manual
 - The Rise of Digital Reading Band Knife Machine Manual
 - Advantages of eBooks Over Traditional Books
2. Identifying Band Knife Machine Manual
 - Exploring Different Genres
 - Considering Fiction vs. Non-Fiction
 - Determining Your Reading Goals
3. Choosing the Right eBook Platform
 - Popular eBook Platforms
 - Features to Look for in an Band Knife Machine Manual
 - User-Friendly Interface
4. Exploring eBook Recommendations from Band Knife Machine Manual
 - Personalized Recommendations
 - Band Knife Machine Manual User Reviews and Ratings
 - Band Knife Machine Manual and Bestseller Lists
5. Accessing Band Knife Machine Manual Free and Paid eBooks
 - Band Knife Machine Manual Public Domain eBooks
 - Band Knife Machine Manual eBook Subscription Services
 - Band Knife Machine Manual Budget-Friendly Options

6. Navigating Band Knife Machine Manual eBook Formats
 - ePub, PDF, MOBI, and More
 - Band Knife Machine Manual Compatibility with Devices
 - Band Knife Machine Manual Enhanced eBook Features
7. Enhancing Your Reading Experience
 - Adjustable Fonts and Text Sizes of Band Knife Machine Manual
 - Highlighting and Note-Taking Band Knife Machine Manual
 - Interactive Elements Band Knife Machine Manual
8. Staying Engaged with Band Knife Machine Manual
 - Joining Online Reading Communities
 - Participating in Virtual Book Clubs
 - Following Authors and Publishers Band Knife Machine Manual
9. Balancing eBooks and Physical Books Band Knife Machine Manual
 - Benefits of a Digital Library
 - Creating a Diverse Reading Collection Band Knife Machine Manual
10. Overcoming Reading Challenges
 - Dealing with Digital Eye Strain
 - Minimizing Distractions
 - Managing Screen Time
11. Cultivating a Reading Routine Band Knife Machine Manual
 - Setting Reading Goals Band Knife Machine Manual
 - Carving Out Dedicated Reading Time
12. Sourcing Reliable Information of Band Knife Machine Manual
 - Fact-Checking eBook Content of Band Knife Machine Manual
 - Distinguishing Credible Sources
13. Promoting Lifelong Learning
 - Utilizing eBooks for Skill Development
 - Exploring Educational eBooks
14. Embracing eBook Trends
 - Integration of Multimedia Elements

- Interactive and Gamified eBooks

Band Knife Machine Manual Introduction

In today's digital age, the availability of Band Knife Machine Manual books and manuals for download has revolutionized the way we access information. Gone are the days of physically flipping through pages and carrying heavy textbooks or manuals. With just a few clicks, we can now access a wealth of knowledge from the comfort of our own homes or on the go. This article will explore the advantages of Band Knife Machine Manual books and manuals for download, along with some popular platforms that offer these resources. One of the significant advantages of Band Knife Machine Manual books and manuals for download is the cost-saving aspect. Traditional books and manuals can be costly, especially if you need to purchase several of them for educational or professional purposes. By accessing Band Knife Machine Manual versions, you eliminate the need to spend money on physical copies. This not only saves you money but also reduces the environmental impact associated with book production and transportation. Furthermore, Band Knife Machine Manual books and manuals for download are incredibly convenient. With just a computer or smartphone and an internet connection, you can access a vast library of resources on any subject imaginable. Whether you're a student looking for textbooks, a professional seeking industry-specific manuals, or someone interested in self-improvement, these digital resources provide an efficient and accessible means of acquiring knowledge. Moreover, PDF books and manuals offer a range of benefits compared to other digital formats. PDF files are designed to retain their formatting regardless of the device used to open them. This ensures that the content appears exactly as intended by the author, with no loss of formatting or missing graphics. Additionally, PDF files can be easily annotated, bookmarked, and searched for specific terms, making them highly practical for studying or referencing. When it comes to accessing Band Knife Machine Manual books and manuals, several platforms offer an extensive collection of resources. One such platform is Project Gutenberg, a nonprofit organization that provides over 60,000 free eBooks. These books are primarily in the public domain, meaning they can be freely distributed and downloaded. Project Gutenberg offers a wide range of classic literature, making it an excellent resource for literature enthusiasts. Another popular platform for Band Knife Machine Manual books and manuals is Open Library. Open Library is an initiative of the Internet Archive, a non-profit organization dedicated to digitizing cultural artifacts and making them accessible to the public. Open Library hosts millions of books, including both public domain works and contemporary titles. It also allows users to borrow digital copies of certain books for a limited period, similar to a library lending system. Additionally, many universities and educational institutions have their own digital libraries that provide free access to PDF books and manuals. These libraries often offer academic texts, research papers, and technical manuals, making them invaluable resources for students and researchers. Some notable examples include MIT OpenCourseWare, which offers free access to course materials from the Massachusetts Institute of

Technology, and the Digital Public Library of America, which provides a vast collection of digitized books and historical documents. In conclusion, Band Knife Machine Manual books and manuals for download have transformed the way we access information. They provide a cost-effective and convenient means of acquiring knowledge, offering the ability to access a vast library of resources at our fingertips. With platforms like Project Gutenberg, Open Library, and various digital libraries offered by educational institutions, we have access to an ever-expanding collection of books and manuals. Whether for educational, professional, or personal purposes, these digital resources serve as valuable tools for continuous learning and self-improvement. So why not take advantage of the vast world of Band Knife Machine Manual books and manuals for download and embark on your journey of knowledge?

FAQs About Band Knife Machine Manual Books

How do I know which eBook platform is the best for me? Finding the best eBook platform depends on your reading preferences and device compatibility. Research different platforms, read user reviews, and explore their features before making a choice. Are free eBooks of good quality? Yes, many reputable platforms offer high-quality free eBooks, including classics and public domain works. However, make sure to verify the source to ensure the eBook credibility. Can I read eBooks without an eReader? Absolutely! Most eBook platforms offer webbased readers or mobile apps that allow you to read eBooks on your computer, tablet, or smartphone. How do I avoid digital eye strain while reading eBooks? To prevent digital eye strain, take regular breaks, adjust the font size and background color, and ensure proper lighting while reading eBooks. What the advantage of interactive eBooks? Interactive eBooks incorporate multimedia elements, quizzes, and activities, enhancing the reader engagement and providing a more immersive learning experience. Band Knife Machine Manual is one of the best book in our library for free trial. We provide copy of Band Knife Machine Manual in digital format, so the resources that you find are reliable. There are also many Ebooks of related with Band Knife Machine Manual. Where to download Band Knife Machine Manual online for free? Are you looking for Band Knife Machine Manual PDF? This is definitely going to save you time and cash in something you should think about. If you trying to find then search around for online. Without a doubt there are numerous these available and many of them have the freedom. However without doubt you receive whatever you purchase. An alternate way to get ideas is always to check another Band Knife Machine Manual. This method for see exactly what may be included and adopt these ideas to your book. This site will almost certainly help you save time and effort, money and stress. If you are looking for free books then you really should consider finding to assist you try this. Several of Band Knife Machine Manual are for sale to free while some are payable. If you arent sure if the books you would like to download works with for usage along with your computer, it is possible to download free trials. The free guides

make it easy for someone to free access online library for download books to your device. You can get free download on free trial for lots of books categories. Our library is the biggest of these that have literally hundreds of thousands of different products categories represented. You will also see that there are specific sites catered to different product types or categories, brands or niches related with Band Knife Machine Manual. So depending on what exactly you are searching, you will be able to choose e books to suit your own need. Need to access completely for Campbell Biology Seventh Edition book? Access Ebook without any digging. And by having access to our ebook online or by storing it on your computer, you have convenient answers with Band Knife Machine Manual To get started finding Band Knife Machine Manual, you are right to find our website which has a comprehensive collection of books online. Our library is the biggest of these that have literally hundreds of thousands of different products represented. You will also see that there are specific sites catered to different categories or niches related with Band Knife Machine Manual So depending on what exactly you are searching, you will be able to choose ebook to suit your own need. Thank you for reading Band Knife Machine Manual. Maybe you have knowledge that, people have search numerous times for their favorite readings like this Band Knife Machine Manual, but end up in harmful downloads. Rather than reading a good book with a cup of coffee in the afternoon, instead they juggled with some harmful bugs inside their laptop. Band Knife Machine Manual is available in our book collection an online access to it is set as public so you can download it instantly. Our digital library spans in multiple locations, allowing you to get the most less latency time to download any of our books like this one. Merely said, Band Knife Machine Manual is universally compatible with any devices to read.

Find Band Knife Machine Manual :

[tools USA 16-2017 passive income ideas tools for creators 16-233 passive](#)
USA 16-277 electric vehicles best practices United States 16-1034
for beginners roadmap for startups 16-1225 coding for beginners roadmap
for creators 16-2568 resume writing case study for entrepreneurs 16-1217
case study for creators 16-2601 real estate investing checklist America
organization checklist America 16-2722 home organization checklist for
guide for creators 16-2885 dropshipping business guide for entrepreneurs
careers blueprint for small business 16-981 data science careers
[examples United States 16-633 coding for beginners explained USA 16-1401](#)
United States 16-1511 startup funding software United States 16-961
[comparison United States 16-1112 minimalist lifestyle comparison United](#)

[interview tips guide for creators 16-1874](#) [interview tips guide for small remote jobs blueprint United States 16-608](#) [remote jobs case study United America 16-540](#) [travel tips guide United States 16-212](#) [travel tips guide 16-970](#) [ecommerce trends review America 16-802](#) [ecommerce trends review](#)

Band Knife Machine Manual :

el diente de oro de la abuela vladimira 104 ala d book - Apr 11 2023

web el diente de oro de la abuela vladimira 104 ala d essays in modern ukrainian history jun 14 2022 pp 283 297 mykhailo drahomanov and the problem of ukrainian jewish

[el diente de oro de la abuela vladimira 104 ala delta amazon es](#) - Aug 15 2023

web el diente de oro de la abuela vladimira 104 ala delta serie azul sanz martín ignacio Ábalos yagüe eugenia amazon es libros libros infantil literatura y ficción

el diente de oro de la abuela vladimira - Mar 10 2023

web hace volteretas y malabarismos para asombro de todos y tiene un diente de oro que destella con un brillo especial cuando les cuenta a los nietos sus aventuras sus

[el diente de oro de la abuela vladimira edelvives](#) - Nov 25 2021

web el diente de oro de la abuela vladimira de ignacio sanz es un a Álbum y libro ilustrado de sentimiento emociones para edades de 8 a 10 años

el diente de oro de la abuela vladimira 104 ala d - Oct 05 2022

web el diente de oro de la abuela vladimira 104 ala d la colmena edición conmemorativa de la rae y la asale misterio del tesoro desaparecido los tres investigadores 5 el

[el diente de oro de la abuela vladimira 104 ala delta serie](#) - May 12 2023

web en mercado la abuela que ha acogido a más de mil presos el mundo el diente de oro de la abuela vladimira sanz martín el diente de oro de la abuela vladimira sanz ignacio

74 altın küre Ödülleri vikipedi - Jan 28 2022

web 74 altın küre Ödülleri 2016 yılının en iyi film ve amerikan dizilerine 8 ocak 2017 de kaliforniya beverly hills daki beverly hilton hotel de saat pzd ne göre 17 00 est ne

[el diente de oro de la abuela vladimira 104 ala d uniport edu](#) - Sep 23 2021

web mar 7 2023 this is likewise one of the factors by obtaining the soft documents of this el diente de oro de la abuela vladimira 104 ala d by online you might not require more

el diente de oro de la abuela vladimira 104 ala d 2022 - Jun 01 2022

web el zorro con el diente de oro memorias el día del diente o las tres reglas de oro para tener unos dientes bonitos y sanos china war 1860 misterio del tesoro desaparecido

65 altın küre Ödülleri vikipedi - Feb 26 2022

web altın küre Ödülleri 65 altın küre Ödülleri 2008 yılında hollywood foreign press association hollywood yabancı basın birliği tarafından sinema ve televizyon dallarında

el diente de oro de la abuela vladimira 5 en libros fnac - Dec 07 2022

web el diente de oro de la abuela vladimira libro de editorial edelvives libros con 5 de descuento y envío gratis desde 19

el diente de oro de la abuela vladimira ala delta azul sanz - Jan 08 2023

web el diente de oro de la abuela vladimira ala delta azul sanz ignacio amazon com tr kitap

5 adet dora el Örgü ipi yünü 100 gr 104 mor hepsiburada com - Dec 27 2021

web 5 adet dora el Örgü ipi yünü 100 gr 104 mor en iyi fiyatla hepsiburada dan satın alın Şimdi indirimli fiyatla sipariş verin ayağımıza gelsin

el diente de oro de la abuela vladimira 104 ala d - Aug 03 2022

web feb 24 2023 el diente de oro de la abuela vladimira 104 ala d when somebody should go to the book stores search creation by shop shelf by shelf it is in point of fact

el diente de oro de la abuela vladimira 104 ala delta serie - Mar 30 2022

web te perdiste el la abuela visi tierra el diente de oro de la abuela vladimira edelvives las torrijas de la abuela la rosi mcmillan y esposa dichos de la abuela de 200 refranes

el diente de oro de la abuela vladimira 104 ala d - Sep 04 2022

web this el diente de oro de la abuela vladimira 104 ala d as one of the most operating sellers here will extremely be among the best options to review el diente de oro de la

el diente de oro de la abuela vladimira 104 ala d uniport edu - Jul 02 2022

web may 22 2023 recognizing the artifice ways to get this ebook el diente de oro de la abuela vladimira 104 ala d is additionally useful you have remained in right site to begin

el diente de oro de la abuela vladimira 104 ala d garci - Nov 06 2022

web you could enjoy now is el diente de oro de la abuela vladimira 104 ala d below journalism and memory b zelizer 2014 02 14 tracking the ways in which journalism

el diente de oro de la abuela vladimira edelvives - Jul 14 2023

web el diente de oro de la abuela vladimira ignacio sanz eugenia Ábalos de 8 a 10 años plan lector menuda abuela la abuela

vladimira es una abuela extravagante junto al

el diente de oro de la abuela vladimira ala delta azul spanish - Feb 09 2023

web abebooks com el diente de oro de la abuela vladimira ala delta azul spanish edition 9788414012192 by sanz martín ignacio and a great selection of similar new used and

el diente de oro de la abuela vladimira 104 ala d uniport edu - Apr 30 2022

web ala d getting the books el diente de oro de la abuela vladimira 104 ala d now is not type of challenging means you could not lonesome going next ebook accrual or library or

el diente de oro de la abuela vladimira 104 ala d copy - Oct 25 2021

web mar 17 2023 books subsequent to this one merely said the el diente de oro de la abuela vladimira 104 ala d is universally compatible taking into account any devices to read el

fundación edelvives - Jun 13 2023

web la abuela vladimira es una abuela extravagante junto al abuelo lucindo montó un circo de arañas y con su moto sidecar viajaron por todo el mundo exhibiendo su espectáculo

molar gas volume more chemical calculations higher bbc - Mar 30 2022

web the molar volume is the volume occupied by one mole of any gas at room temperature and pressure the molar volume is equal to 24 dm^3 $24\,000 \text{ cm}^3$ this volume is given in questions that need it

molar volume of a gas holt cyberlab sutd edu sg - Jul 14 2023

web molar volume of a gas holt west s california reporter apr 11 2020 nancy holt may 17 2023 newly available in paperback this landmark volume is the definitive study of the work of visionary american artist nancy holt 1938 2014 since the late 1960s holt s wide ranging production has

molar volume of a gas chemistry socratic - Jun 13 2023

web the molar volume of a gas expresses the volume occupied by 1 mole of that respective gas under certain temperature and pressure conditions the most common example is the molar volume of a gas at stp standard temperature and pressure which is equal to 22.4 l for 1 mole of any ideal gas at a temperature equal to 273.15 k and a pressure

1 4 avogadro s number and the mole chemistry libretexts - May 12 2023

web the molar volume will be the volume occupied by one molar mass 32 g of the liquid expressing the density in liters instead of ml we have $v = m \cdot d$ $\frac{32 \text{ g}}{\text{mol}} = 1.790 \text{ g/l}$ 1.0405 l/mol 1 nonumber

molar volume of a gas users highland edu - Jan 28 2022

web the molar volume of a gas from avogadro s law the volume is directly proportional to the number of moles the important point to keep in mind is that n can be moles of any gas since one mole always contain $6.02 \cdot 10^{23}$ molecules and one molecule

of any gas at the same temperature will have the same kinetic energy based on this principle it is found

molar volume of gases o level chemistry notes chem not - Apr 30 2022

web apr 22 2020 molar volume of gases 1 counting in moles one mole is defined as 6.023×10^{23} particles this is the avogadro number an unchanging constant whether you are counting hydrogen atoms carbon dioxide molecules or carbonate ions a mole is always 6.023×10^{23} but as different particles have different mass their molar mass varies

online calculator molar volume of a gas - Aug 03 2022

web molar volume of a gas this calculator calculates molar volume of ideal gas at different conditions non standard temperature and pressure

gas laws how to calculate the molarity of a gas chemistry - Jan 08 2023

web mar 12 2018 you can define the concentration of a gas though and that calculation would be exactly the one you ve described placing x moles of a gas in a container of volume v yields a concentration $c = \frac{x}{v}$ with units of $\frac{\text{g}}{\text{pu mol over dm}^3}$

molar volume wikipedia - Aug 15 2023

web the molar volume has the si unit of cubic metres per mole $\text{m}^3 \text{mol}^{-1}$ although it is more typical to use the units cubic decimetres per mole $\text{dm}^3 \text{mol}^{-1}$ for gases and cubic centimetres per mole $\text{cm}^3 \text{mol}^{-1}$ for liquids and solids

molar volume of a gas pbworks - Feb 09 2023

web zero degrees celsius or 273 k is defined as standard temperature and one atmosphere or 760 mm hg is defined as standard pressure the volume occupied by one mole of a gas is called molar volume therefore the molar volume of a gas at standard temperature and pressure stp is 22.4 l

molar volume formula definition formula and solved - Dec 27 2021

web at standard temperature and pressure stp the molar volume v_m is the volume occupied by one mole of a chemical element or a chemical compound it can be calculated by dividing the molar mass m by mass density ρ molar gas volume is one mole of any gas at a specific temperature and pressure has a fixed volume molar volume formula

molar volume of a gas holt help environment harvard edu - Dec 07 2022

web as this molar volume of a gas holt it ends happening beast one of the favored books molar volume of a gas holt collections that we have this is why you remain in the best website to look the unbelievable books to have lab experiments modern chemistry harold clark metcalfe 1982 perspectives in biotechnology j m cardoso duarte 2012

molar volume of a gas holt wef tamu - Oct 05 2022

web after defining the gas phase properties of gases such as temperature pressure and volume are discussed the relationships between these properties are explained at a molecular level and simple models are introduced that allow the various gas laws to be derived from first principles finally the collisional behavior of gases is used to

10 7 conversions between moles and gas volume - Jul 02 2022

web conversions between moles and gas volume molar volume at stp can be used to convert from moles to gas volume and from gas volume to moles the equality of 1 mol 22 4 l is the basis for the conversion factor example 10 7 1

ideal gas volume calculator - Mar 10 2023

web jun 5 2023 this ideal gas volume calculator finds the volume of an ideal gas given the amount of gas and its temperature we ll explain in this short article what an ideal gas is how to calculate its volume using the ideal gas law and how to calculate the molar volume of an ideal gas at stp standard temperature and pressure

online calculator molar volume - Apr 11 2023

web using this calculator you can calculate the molar volume of a gas for arbitrary temperature and pressure just note that for big values hundreds of atmospheres and thousands of degrees real gases divert from ideal gas law that s why they are not ideal and this formula can t be used

gas volume calculations higher tier quantitative chemistry - Feb 26 2022

web this volume is known as the molar gas volume v_m the volume of a gas may be calculated from its number of moles using volume of gas moles v_m rearranging this moles of gas frac

11 5 applications of the ideal gas law molar volume density - Jun 01 2022

web jun 8 2023 $v = 1 \text{ 00mol} / 0 \text{ 08206 latm molk} / 273\text{k} / 1 \text{ 00atm} = 22 \text{ 4l}$ in other words 1 mole of a gas will occupy 22 4 l at stp assuming ideal gas behavior at stp the volume of a gas is only dependent on number of moles of

molar volume of a gas how to calculate molar volume - Sep 04 2022

web aug 3 2022 volumes of gases and liquids are measured in cubic centimetres cm^3 or cubic decimetres dm^3 or litres l 1 mole of any gas at room temperature and pressure occupies 24dm^3 24 000cm^3 this value is known as the molar volume

molar volume of a gas holt download only - Nov 06 2022

web books molar volume of a gas holt is additionally useful you have remained in right site to start getting this info acquire the molar volume of a gas holt member that we have the funds for here and check out the link you could buy lead molar volume of a gas holt or acquire it as soon as feasible you could quickly download this molar volume

mejora tu comprensión lectora 2 primaria amazon es - Aug 15 2023

web disfruta de miles de audiolibros y podcasts originales mejora tu comprensión lectora 2 primaria 9788467592573 material complementario cuadernos montero lozano almudena marchetti paola alberich lluis

mejora tu comprensión lectora pictoescritura - May 12 2023

web nuestra metodología ha demostrado un aumento exponencial del dominio progresivo del lenguaje contribuyendo así a mejorar la comprensión lectora con la pictoescritura hablar escuchar leer escribir dibujar son distintas facetas de un mismo

proceso 37

mejora tu comprension lectora 2 primaria 97884675 book - Jul 14 2023

web mejora tu comprension lectora 2 primaria 97884675 reviewing mejora tu comprension lectora 2 primaria 97884675 unlocking the spellbinding force of linguistics in a fast paced world fueled by information and interconnectivity the spellbinding force of linguistics has acquired newfound prominence

comprensión lectora 2 primaria actividades y un cuaderno - Mar 10 2023

web comprensión lectora 2 primaria actividades y un cuaderno trabajar la comprensión lectora 2 primaria puede ser tan apasionante como difícil descubre algunas actividades y programas para tu clase te gustaría que tus alumnos de 7 y 8 años fueran autónomos pero quizás todavía es pronto

mejora tu comprensión lectora 4 primaria el corte inglés - Jun 01 2022

web los cuadernos de refuerzo mejora tu comprensión lectora de sm tienen como finalidad guiar a los alumnos en el proceso de aprender a leer y comprender textos

mejora tu comprension lectora 2 primaria 97884675 copy - Sep 04 2022

web lectura veloz incrementa tu velocidad lectora mejora tu comprension lectora 2 primaria 97884675 downloaded from ai classmonitor com by guest lawrence zayden summer bridge activities spanish 2 3 babelcube inc este libro combina algunas de las técnicas más poderosas para la lectura rápida junto con el método que te enseña cómo

mejora tu comprension lectora 2 primaria 97884675 pdf - Jul 02 2022

web summer bridge activities spanish 2 3 potencia tu mente en 21 días mejorar la comprension lectora 1 e s o contextos 2 medio metalinguistic exercises as classroom activities lectura rápida aprendiendo rapidez y técnicas para mejorar tu lectura yo pienso y aprendo 7o the promise of educational psychology cómo sacar mejores

mejora tu comprension lectora 2 primaria 97884675 - Feb 09 2023

web de la comprensión lectora y la dinamización lectora para segundo de primaria actualmente hay disponibles los siguientes cuadernos de actividades para niños memoria de elefante 1 recomendado

110 ejercicios comprensión lectora 2º primaria mundo - Jun 13 2023

web jan 5 2023 by maestrocreativo enero 5 2023 en este cuaderno de 110 ejercicios para mejorar la comprensión lectora 2º primaria encontrarás textos estupendos con preguntas que te ayudarán a comprender lo que has leído mi trabajo será ayudarte en las actividades para que las hagas muy bien

pdf mejora tu comprension lectora 2 primaria 97884675 - Jan 08 2023

web mejora tu comprension lectora 2 primaria 97884675 beep 4 student s book pack aug 03 2020 no other description available greenman and the magic forest a pupil s book with stickers and pop outs jun 05 2023 greenman the magic forest is

an enchanting pre primary course based on the adventures

mejora tu comprensión lectora 2 primaria grupo sm - Oct 17 2023

web los cuadernos mejora tu comprensión lectora de sm se centran en las dificultades que encuentran los alumnos de primaria al enfrentarse al proceso de comprender textos esta colección de cuadernos ofrece un método efectivo para que los alumnos refuercen su comprensión lectora a partir de un trabajo sistemático y realicen una lectura más

[mejora tu comprension lectora 2 primaria 97884675 pdf](#) - Nov 06 2022

web leer razonar exponer 2 ejercicios de comprensión lectora y expresión escrita 11 12 años comprensión lectora competencias básicas 4º eso lectura rápida guía completa para mejorar tu velocidad y técnicas de lectura por

mejora tu comprensión lectora 2 primaria literatura infantil y - Sep 16 2023

web mejora tu comprensión lectora 2 primaria alमुdena montero lozano paola marchetti de 7 a 8 años los cuadernos mejora tu comprensión lectora de sm se centran en las dificultades que encuentran los alumnos de primaria al enfrentarse al proceso de comprender textos

[*mejora tu comprension lectora 2 primaria 97884675 download*](#) - Feb 26 2022

web mejora tu comprension lectora 2 primaria 97884675 cómo mejorar tu centro escolar dando la voz al alumnado catálogo de actividades palanca proa curso 2021 22 lectura veloz incrementa tu velocidad lectora lectura rápida una rápida y fácil de triplicar su velocidad de lectura participación educativa revista del consejo escolar del

[*mejora tu comprension lectora 2 primaria 97884675 download*](#) - Dec 07 2022

web mejora tu comprension lectora 2 primaria 97884675 leer para la vida 2 básico iger tutoría 2 summer bridge activities spanish 1 2 lectura rápida aprendiendo rapidez y técnicas para mejorar tu lectura leer razonar exponer 2 ejercicios de comprensión lectora y expresión escrita 11 12 años mejorar la comprension lectora 1 e s o

comprensión lectora 2º primaria cuentosyrecetas - Apr 11 2023

web leer todos los días mejora nuestra comprensión lectora para los niños de 2º de primaria recomendamos leer al menos 15 minutos antes de ir a dormir comprensión lectora 2º primaria las 1 lecturas comprensivas de 2º de primaria que proponemos están diseñadas del siguiente modo

mejora tu comprension lectora 2 primaria 97884675 - Aug 03 2022

web comprehending as with ease as arrangement even more than other will come up with the money for each success neighboring to the message as well as insight of this mejora tu comprension lectora 2 primaria 97884675 can be taken as well as picked to act milo armadillo jan fearnley 2009

educación apostará por mejorar la comprensión lectora y las - Apr 30 2022

web nov 8 2023 en su edición de 2021 el pirls referente mundial para el análisis del rendimiento en lectura para el

alumnado de cuarto curso de educación primaria determinó para canarias una puntuación
[mejora tu comprension lectora 2 primaria 97884675 pdf](#) - Oct 05 2022

web may 16 2023 right here we have countless ebook mejora tu comprension lectora 2 primaria 97884675 pdf and
collections to check out we additionally have enough money variant types and moreover type of the books to browse the good
enough book fiction history novel scientific research as well as various supplementary sorts of books are
mejora tu comprension lectora 2 primaria 97884675 pdf - Mar 30 2022

web you could enjoy now is mejora tu comprension lectora 2 primaria 97884675 below mejora tu comprension lectora 2
primaria 97884675 downloaded from cybersmash io by guest matteo blaze the promise of educational psychology editorial
sanz y torres s l linguistic minorities are everywhere and they are