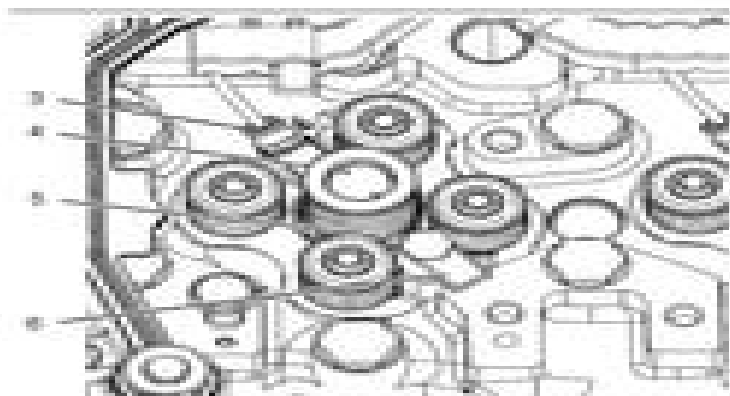
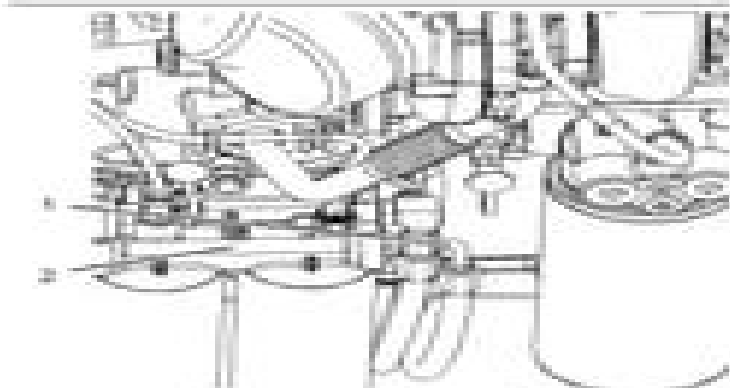

## Disassembly and Assembly Section

Illustration 21 UDN94508

8. Install clamp (5) to electronic unit injector (4). Install the electronic unit injector into the original location in the cylinder head.
9. Install bolt (3). Tighten the bolt to a torque of 55.14 m (41 lb ft).
10. Connect harness connector (2) to electronic unit injector (4).

Illustration 22 UDN94508

11. Connect hose (1) to fuel filter base (2).
12. Turn the fuel supply to the "ON" position.

13. Remove the air from the fuel system. Refer to Operation and Maintenance Manual, "Fuel System - Prime".

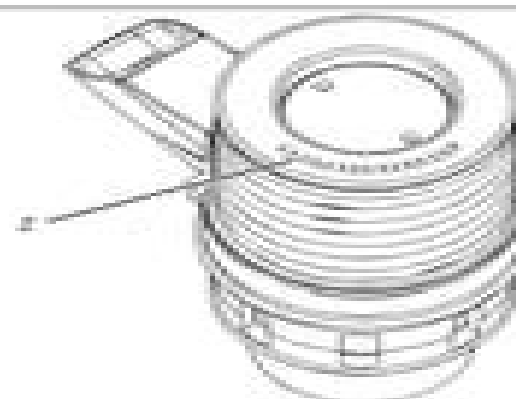
Illustration 23 UDN94508

14. For any replacement electronic unit injectors, record the injector serial number (2) located on top of electronic unit injector (1). The injector serial numbers will be used for downloading trim files for new or exchanged electronic unit injectors (1). Refer to Troubleshooting, "Injector Trim Calibration" for the correct procedure for injector trim calibration.

**End By:**

- a. Install the rocker shafts. Refer to Disassembly and Assembly, "Rocker Shaft and Pushrod - Install".

UDN94508

## Electronic Unit Injector Sleeve - Remove

### Removal Procedure

Table 1

Required Tools			
Tool	Part Number	Part Description	Qty
A.	0250021	Injector Sleeve Tool	1

# Perkins Engine Model 2200 Workshop Manual

**L Reisser**



**Perkins Engine Model 2200 Workshop Manual:**

## Whispering the Techniques of Language: An Mental Journey through **Perkins Engine Model 2200 Workshop Manual**

In a digitally-driven world wherever monitors reign great and instant communication drowns out the subtleties of language, the profound strategies and psychological subtleties concealed within words frequently go unheard. Yet, set within the pages of **Perkins Engine Model 2200 Workshop Manual** a interesting literary value sporting with natural feelings, lies an exceptional quest waiting to be undertaken. Composed by a skilled wordsmith, that wonderful opus attracts readers on an introspective trip, lightly unraveling the veiled truths and profound affect resonating within ab muscles fabric of each word. Within the mental depths of the touching review, we can embark upon a honest exploration of the book is key themes, dissect their interesting publishing design, and succumb to the powerful resonance it evokes serious within the recesses of readers hearts.

<https://py.bijouxmedusa.com/About/Resources/index.jsp/889367081x%20iit1.pdf>

### **Table of Contents Perkins Engine Model 2200 Workshop Manual**

1. Understanding the eBook Perkins Engine Model 2200 Workshop Manual
  - The Rise of Digital Reading Perkins Engine Model 2200 Workshop Manual
  - Advantages of eBooks Over Traditional Books
2. Identifying Perkins Engine Model 2200 Workshop Manual
  - Exploring Different Genres
  - Considering Fiction vs. Non-Fiction
  - Determining Your Reading Goals
3. Choosing the Right eBook Platform
  - Popular eBook Platforms
  - Features to Look for in an Perkins Engine Model 2200 Workshop Manual
  - User-Friendly Interface
4. Exploring eBook Recommendations from Perkins Engine Model 2200 Workshop Manual
  - Personalized Recommendations

- Perkins Engine Model 2200 Workshop Manual User Reviews and Ratings
- Perkins Engine Model 2200 Workshop Manual and Bestseller Lists
- 5. Accessing Perkins Engine Model 2200 Workshop Manual Free and Paid eBooks
  - Perkins Engine Model 2200 Workshop Manual Public Domain eBooks
  - Perkins Engine Model 2200 Workshop Manual eBook Subscription Services
  - Perkins Engine Model 2200 Workshop Manual Budget-Friendly Options
- 6. Navigating Perkins Engine Model 2200 Workshop Manual eBook Formats
  - ePub, PDF, MOBI, and More
  - Perkins Engine Model 2200 Workshop Manual Compatibility with Devices
  - Perkins Engine Model 2200 Workshop Manual Enhanced eBook Features
- 7. Enhancing Your Reading Experience
  - Adjustable Fonts and Text Sizes of Perkins Engine Model 2200 Workshop Manual
  - Highlighting and Note-Taking Perkins Engine Model 2200 Workshop Manual
  - Interactive Elements Perkins Engine Model 2200 Workshop Manual
- 8. Staying Engaged with Perkins Engine Model 2200 Workshop Manual
  - Joining Online Reading Communities
  - Participating in Virtual Book Clubs
  - Following Authors and Publishers Perkins Engine Model 2200 Workshop Manual
- 9. Balancing eBooks and Physical Books Perkins Engine Model 2200 Workshop Manual
  - Benefits of a Digital Library
  - Creating a Diverse Reading Collection Perkins Engine Model 2200 Workshop Manual
- 10. Overcoming Reading Challenges
  - Dealing with Digital Eye Strain
  - Minimizing Distractions
  - Managing Screen Time
- 11. Cultivating a Reading Routine Perkins Engine Model 2200 Workshop Manual
  - Setting Reading Goals Perkins Engine Model 2200 Workshop Manual
  - Carving Out Dedicated Reading Time
- 12. Sourcing Reliable Information of Perkins Engine Model 2200 Workshop Manual
  - Fact-Checking eBook Content of Perkins Engine Model 2200 Workshop Manual

- Distinguishing Credible Sources
- 13. Promoting Lifelong Learning
  - Utilizing eBooks for Skill Development
  - Exploring Educational eBooks
- 14. Embracing eBook Trends
  - Integration of Multimedia Elements
  - Interactive and Gamified eBooks

### **Perkins Engine Model 2200 Workshop Manual Introduction**

In today's digital age, the availability of Perkins Engine Model 2200 Workshop Manual books and manuals for download has revolutionized the way we access information. Gone are the days of physically flipping through pages and carrying heavy textbooks or manuals. With just a few clicks, we can now access a wealth of knowledge from the comfort of our own homes or on the go. This article will explore the advantages of Perkins Engine Model 2200 Workshop Manual books and manuals for download, along with some popular platforms that offer these resources. One of the significant advantages of Perkins Engine Model 2200 Workshop Manual books and manuals for download is the cost-saving aspect. Traditional books and manuals can be costly, especially if you need to purchase several of them for educational or professional purposes. By accessing Perkins Engine Model 2200 Workshop Manual versions, you eliminate the need to spend money on physical copies. This not only saves you money but also reduces the environmental impact associated with book production and transportation. Furthermore, Perkins Engine Model 2200 Workshop Manual books and manuals for download are incredibly convenient. With just a computer or smartphone and an internet connection, you can access a vast library of resources on any subject imaginable. Whether you're a student looking for textbooks, a professional seeking industry-specific manuals, or someone interested in self-improvement, these digital resources provide an efficient and accessible means of acquiring knowledge. Moreover, PDF books and manuals offer a range of benefits compared to other digital formats. PDF files are designed to retain their formatting regardless of the device used to open them. This ensures that the content appears exactly as intended by the author, with no loss of formatting or missing graphics. Additionally, PDF files can be easily annotated, bookmarked, and searched for specific terms, making them highly practical for studying or referencing. When it comes to accessing Perkins Engine Model 2200 Workshop Manual books and manuals, several platforms offer an extensive collection of resources. One such platform is Project Gutenberg, a nonprofit organization that provides over 60,000 free eBooks. These books are primarily in the public domain, meaning they can be freely distributed and downloaded. Project Gutenberg offers a wide range of classic literature, making it an excellent resource for literature enthusiasts. Another popular platform for

Perkins Engine Model 2200 Workshop Manual books and manuals is Open Library. Open Library is an initiative of the Internet Archive, a non-profit organization dedicated to digitizing cultural artifacts and making them accessible to the public. Open Library hosts millions of books, including both public domain works and contemporary titles. It also allows users to borrow digital copies of certain books for a limited period, similar to a library lending system. Additionally, many universities and educational institutions have their own digital libraries that provide free access to PDF books and manuals. These libraries often offer academic texts, research papers, and technical manuals, making them invaluable resources for students and researchers. Some notable examples include MIT OpenCourseWare, which offers free access to course materials from the Massachusetts Institute of Technology, and the Digital Public Library of America, which provides a vast collection of digitized books and historical documents. In conclusion, Perkins Engine Model 2200 Workshop Manual books and manuals for download have transformed the way we access information. They provide a cost-effective and convenient means of acquiring knowledge, offering the ability to access a vast library of resources at our fingertips. With platforms like Project Gutenberg, Open Library, and various digital libraries offered by educational institutions, we have access to an ever-expanding collection of books and manuals. Whether for educational, professional, or personal purposes, these digital resources serve as valuable tools for continuous learning and self-improvement. So why not take advantage of the vast world of Perkins Engine Model 2200 Workshop Manual books and manuals for download and embark on your journey of knowledge?

### **FAQs About Perkins Engine Model 2200 Workshop Manual Books**

1. Where can I buy Perkins Engine Model 2200 Workshop Manual books? Bookstores: Physical bookstores like Barnes & Noble, Waterstones, and independent local stores. Online Retailers: Amazon, Book Depository, and various online bookstores offer a wide range of books in physical and digital formats.
2. What are the different book formats available? Hardcover: Sturdy and durable, usually more expensive. Paperback: Cheaper, lighter, and more portable than hardcovers. E-books: Digital books available for e-readers like Kindle or software like Apple Books, Kindle, and Google Play Books.
3. How do I choose a Perkins Engine Model 2200 Workshop Manual book to read? Genres: Consider the genre you enjoy (fiction, non-fiction, mystery, sci-fi, etc.). Recommendations: Ask friends, join book clubs, or explore online reviews and recommendations. Author: If you like a particular author, you might enjoy more of their work.
4. How do I take care of Perkins Engine Model 2200 Workshop Manual books? Storage: Keep them away from direct

sunlight and in a dry environment. Handling: Avoid folding pages, use bookmarks, and handle them with clean hands. Cleaning: Gently dust the covers and pages occasionally.

5. Can I borrow books without buying them? Public Libraries: Local libraries offer a wide range of books for borrowing. Book Swaps: Community book exchanges or online platforms where people exchange books.
6. How can I track my reading progress or manage my book collection? Book Tracking Apps: Goodreads, LibraryThing, and Book Catalogue are popular apps for tracking your reading progress and managing book collections. Spreadsheets: You can create your own spreadsheet to track books read, ratings, and other details.
7. What are Perkins Engine Model 2200 Workshop Manual audiobooks, and where can I find them? Audiobooks: Audio recordings of books, perfect for listening while commuting or multitasking. Platforms: Audible, LibriVox, and Google Play Books offer a wide selection of audiobooks.
8. How do I support authors or the book industry? Buy Books: Purchase books from authors or independent bookstores. Reviews: Leave reviews on platforms like Goodreads or Amazon. Promotion: Share your favorite books on social media or recommend them to friends.
9. Are there book clubs or reading communities I can join? Local Clubs: Check for local book clubs in libraries or community centers. Online Communities: Platforms like Goodreads have virtual book clubs and discussion groups.
10. Can I read Perkins Engine Model 2200 Workshop Manual books for free? Public Domain Books: Many classic books are available for free as they're in the public domain. Free E-books: Some websites offer free e-books legally, like Project Gutenberg or Open Library.

### Find Perkins Engine Model 2200 Workshop Manual :

**889367081x iit1**

8811600251 it2

908753115x iit8

a to quantum groups

**9th edition hornady reloading**

**a history of christianity diarmaid macculloch pdf**

**a guide to numbers on hsbc debit cards**

a text book physical chemistry

8895197720 IT28

**a manual for living a little book of wisdom**

8899781001 bit6

**a2 music harmony workbook**

**a arte de pensar clef**

*86mb file anand kumar pulse and digital circuits*

**a dictionary of civil water resources environmental engineering**

**Perkins Engine Model 2200 Workshop Manual :**

*nursing career 11 examples of professional goals for nurses - Oct 26 2022*

web jan 30 2022 the nursing practicum clinical practice is an essential but often highly stressful aspect of the nursing degree a review of the published literature reveals a

*15 smart goals examples for your nursing career develop - Nov 26 2022*

web realistic consider your situation timely set a time limit smart np student goals for the rest of the post we will examine some simple and smart nurse practitioner student

**10 examples of smart goals for nursing students - Jul 03 2023**

web this course explores leadership and management behaviors theories and techniques in a variety of health care organizations and settings the application and integration of

examples of smart goals for nursing students the nerdy nurse - Sep 05 2023

web mar 31 2023 here are examples of clinical goals nursing students may set out to achieve on their way to becoming qualified nurses 1 strengthen critical thinking

nursing practicum objectives examples onlinenursingpapers - Aug 24 2022

web 25 examples of smart goals for nurses 15 examples of smart goals for nursing students simple goal i want to know where the crash carts fire extinguishers pyxis

**nurs 4140 leadership and management for professional - Jan 29 2023**

web aug 20 2018 embrace collaboration and teamwork learning goals for nursing students examples include proficiency as a team player on a coordinated health care

**learning goals for nursing students the classroom - Jul 23 2022**

web some nursing students learners view practicum experiences in community health as learning and community action goals designed via collaboration between faculty and

examples of professional nursing goals skills education - Jun 02 2023

web oct 19 2022 goals that aren't attainable often lead to frustration when creating a goal examine your current life situation and aim for objectives that aren't beyond your reach

**13 smart goals examples for school nurses success in depth** - Mar 19 2022

*smart goals for nursing students during preceptorship* - Feb 15 2022

**examples of smart goals for nurse practitioner students** - May 21 2022

10 examples of smart goals for nurse practitioner students - Dec 16 2021

*nursing practicum equity for a changing nurse student* - Apr 19 2022

*15 examples of smart goals for nursing students* - Oct 06 2023

web aug 16 2023 examples of professional nursing goals skills education earnings written by coursera updated on aug 16 2023 share discover examples of

*writing learning objectives for nursing university of south* - Feb 27 2023

web the nursing practicum objectives examples assignment 1 2 pages list your practicum objectives that you have identified the number of practicum objectives will vary based

**25 examples of smart goals for nurses lessons** - Dec 28 2022

web mar 11 2023 in this post we're going to learn how to set smart goals in nursing that actually help you achieve success we're going to work through how to improve your

**nursing practicums in health promoting schools a quality** - Jan 17 2022

**15 examples of nursing career goals and how to** - Mar 31 2023

web jan 17 2023 specific the more specific your goals as a nursing student are the better your chance of reaching them having too broad a goal can make it seem like an

smart goals for nursing with 27 clear examples to - Aug 04 2023

web example 5 demonstrate ability to maintain a therapeutic relationship with the client according to national standards whilst performing the client health assessment example

*12 smart goals examples for nursing students success in* - Sep 24 2022

web apr 14 2023 you can read more for 13 examples of smart goals for school nurses 1 boost student health outcomes i want to improve the overall health and well being of

**16 clinical goals and objectives for nursing students** - May 01 2023

web sep 30 2023 join professional organizations as a nurse you can become a member of various professional associations at both local and national levels advancing your career

*how to set smart goals in nursing 2023 real examples* - Jun 21 2022

web aiming for minimal to no assistance by the end of the semester setting goals is an important aspect of personal and professional development as a nurse practitioner

**psychanalyse des Œuvres encyclopædia universalis** - Mar 29 2022

web aug 19 2023 oeuvres complètes psychanalyse vol xvi 1921 1923 by sigmund freud andré bourguignon pierre cotet jean laplanche eco umberto y seboek thomas a p el

oeuvres complètes psychanalyse vol xvi 1921 1923 pdf - Jan 07 2023

web discover the publication oeuvres complètes psychanalyse vol xvi 1921 1923 that you are looking for it will certainly squander the time however below taking into

**oeuvres complètes psychanalyse vol xvi 1921 1923 by** - Oct 24 2021

web jan 2 2019 ultime volume des Œuvres complètes de freud psychanalyse ocf p cet index général rassemble réorganise et complète les index des précédents

*oeuvres complètes psychanalyse vol xvi 1921 1923 pdf* - Sep 03 2022

web cet ouvrage contient les textes concernant la psychanalyse écrits par sigmund freud entre 1921 et 1923 en particulier les textes psychologie des masses et le moi et le ça dans

**oeuvres complètes psychanalyse vol xvi 1921 1923 by** - Mar 09 2023

web 432 pages paperback published september 21 2010 book details editions

*oeuvres complètes psychanalyse volume xvi 1921 1923* - Jul 13 2023

web les textes concernant la psychanalyse écrits par sigmund freud entre 1921 et 1923 en particulier les textes psychologie des masses et le moi et le ça dans une nouvelle

**oeuvres complètes psychanalyse vol xvi 1921 1923** - Feb 08 2023

web oeuvres complètes psychanalyse vol xvi 1921 1923 1 oeuvres complètes psychanalyse vol xvi 1921 1923 freud au cas par cas oeuvres complètes oeuvres

*oeuvres complètes psychanalyse vol xvi 1921 1923* - Jun 12 2023

web oeuvres complètes psychanalyse vol xvi 1921 1923 by sigmund freud andré bourguignon pierre cotet jean laplanche

psychologie des masses et le moi et le ça

*oeuvres complètes psychanalyse vol xvi 1921 1923 by* - Jul 01 2022

web noté 5 retrouvez oeuvres complètes psychanalyse vol xviii 1926 1930 l analyse profane l avenir d une illusion le malaise dans la culture autres textes et des millions

*oeuvres complètes psychanalyse vol xvi 1921 1923* - Apr 10 2023

web cet ouvrage contient les textes concernant la psychanalyse écrits par sigmund freud entre 1921 et 1923 en particulier les textes psychologie des masses et le moi et le ça dans

*oeuvres complètes psychanalyse vol xvi 1921 1923 pdf pdf* - Nov 05 2022

web oeuvres complètes psychanalyse vol xvi 1921 1923 bulletin vol 16 sep 16 2020 excerpt from bulletin vol 16 catalogue 1921 1922 annonces 1922 1923 avril

**oeuvres complètes psychanalyse tome 4 1927 1933 decitre** - Apr 29 2022

web la livraison inaugurale de la revue imago publiée par freud en 1912 avec le concours d otto rank et de hanns sachs nous permet de situer avec précision le projet

*oeuvres complètes psychanalyse vol xvi 1921 1923 by* - May 11 2023

web sep 21 2010 oeuvres complètes psychanalyse vol xvi 1921 1923 psychologie des masses le moi et le ça autres textes freud sigmund on amazon com free

**Œuvres complètes psychanalyse vol xxi index général** - Sep 22 2021

**oeuvres complètes psychanalyse vol xvi 1921 1923 by** - Jan 27 2022

web cet ouvrage contient les textes concernant la psychanalyse écrits par sigmund freud entre 1921 et 1923 en particulier les textes psychologie des masses et le moi et le ça dans

*Œuvres complètes psychanalyse vol xvi 1921 1923* - Aug 14 2023

web get this from a library oeuvres complètes psychanalyse volume xvi 1921 1923 sigmund freud andré bourguignon pierre cotet jean laplanche et al

*oeuvres complètes psychanalyse vol xvi 1921 1923 by* - Aug 02 2022

web oeuvres complètes psychanalyse vol xvi 1921 1923 by sigmund freud andré bourguignon pierre cotet jean laplanche jacques van rillaer del jacques van

**oeuvres complètes psychanalyse vol xvi 1921 1923 by** - Nov 24 2021

web oeuvres complètes psychanalyse vol xvi 1921 1923 by sigmund freud andré bourguignon pierre cotet jean laplanche full text of teora y analisis cultural emile

**oeuvres complètes psychanalyse vol xvi 1921 1923 by** - Dec 26 2021

web oeuvres complètes psychanalyse vol xvi 1921 1923 by sigmund freud andré bourguignon pierre cotet jean laplanche august 17th 2019 el verbo conocer es

*oeuvres complètes psychanalyse vol xvi 1921 1923 by* - Feb 25 2022

web cet ouvrage contient les textes concernant la psychanalyse écrits par sigmund freud entre 1921 et 1923 en particulier les textes psychologie des masses et le moi et le ça dans

**oeuvres complètes psychanalyse vol xviii amazon fr** - May 31 2022

web oct 3 2007 et malgré leurs divergences freud écrit à la mort de ferenczi en 1933 que certains de ses articles ont fait de tous les analystes ses élèves cette édition des

**free oeuvres complètes psychanalyse vol xvi 1921 1923** - Oct 04 2022

web jul 1 2023 vol xvi 1921 1923 pdf and numerous ebook collections from fictions to scientific research in any way in the midst of them is this oeuvres complètes

**oeuvres complètes psychanalyse vol xvi 1921 1923 laurent** - Dec 06 2022

web oeuvres complètes psychanalyse vol xvi 1921 1923 pdf is manageable in our digital library an online access to it is set as public hence you can download it instantly

**practical inorganic chemistry practical inorganic default store** - Jun 14 2023

web practical inorganic chemistry under choice based credit system cbcs scheme of delhi university for bsc hons and programme courses shikha gulati phd department of chemistry sri venkateswara college university of delhi e mail shikha2gulati gmail com jl sharma phd department of chemistry kirori mal college university of delhi shagun

*b chemistry subsidiary jadavpur university* - Oct 06 2022

web 1st semester paper vs paper vis marks 16 16 unit ic s 201 a chemical bonding ii b atomic nuclei radioactivity 15 l unit ic s 202 comparative study of group elements i non transition elements of gr i ii iii noble gases 15 l 2nd semester paper viis paper viiis group c each marks 16 16

**b sc 1st year chemistry practical file 2022 physical inorganic** - Dec 28 2021

web cgexamprep waycotutorials rvakeshb sc 1st year organic chemistry practical file part 3 bschello dosto is video me b sc 1st year ke physical inorg

**b sc inorganic chemistry a previous year question paper** - May 13 2023

web b sc inorganic chemistry a semester 1 b sc inorganic chemistry a semester 2 b sc inorganic chemistry a semester 3 b sc inorganic chemistry a semester 4 b sc inorganic chemistry a semester 5 b sc inorganic chemistry a semester 6 androbose provides solved previous year question papers for bcom

[college practical](#) - Aug 16 2023

web in inorganic chemistry section gravimetric t y b sc chemistry practical 2018 19 semester v paper i code uschp 501 physical chemistry experiments non instrumental i colligative properties 1 to determine the molecular weight of a compound by rast method

[b sc1styr chem pract pdf chemistry practical teachmint](#) - Apr 12 2023

web chemistry 17 likes 3457 views a aarti patel jan 25 2022 study material gaseous state chem pdf b sc

*inorganic chemistry practical paper practical paper bs* - May 01 2022

web sep 12 2023 inorganic chemistry practical paper practical paper bs zoology bs botany bs chemistry learning 5q 24 subscribers no views 5 minutes ago learning bsc3rdyear bs

**inorganic chemistry iii previous question paper for bsc chemistry** - Jun 02 2022

web aug 6 2021 inorganic chemistry iii previous question papers calicut university ug degree course fifth semester bsc chemistry inorganic chemistry iii old year question papers are available to download university calicut university course bsc chemistry semester 5 semester subject inorganic chemistry iii

*bsc 1st year inorganic chemistry notes pdf download here* - Mar 11 2023

web apr 4 2022 bsc 1st year inorganic chemistry notes pdf bsc 1st year consists of two semesters i e semester i and semester ii in this post i have provided the download links of inorganic chemistry notes for bsc sem i as well as sem ii all the notes provided on our website are free to download

**bsc inorganic chemistry practical paper** - Feb 10 2023

web this on line revelation bsc inorganic chemistry practical paper as without difficulty as evaluation them wherever you are now directory of british scientists 1966 a laboratory manual of qualitative organic analysis openshaw

**online library bsc inorganic chemistry practical paper** - Jan 29 2022

web this bsc inorganic chemistry practical paper can be taken as without difficulty as picked to act sh7vup crane erin this textbook has been designed to meet the needs of b sc second semester stu dents of chemistry as per the ugc choice based credit system cbcs with its tradi tional approach to the subject this text

**inorganic chemistry all bsc books and all books question banks** - Jan 09 2023

web chemistry inorganic chemistry organic chemistry physics mechanics electricity and electronic wave and oscillation 2nd year books mathematics abstract algebra real analysis advance calculus numerical analysis mechanics physics optics electronic thermal physics chemistry inorganic chemistry 3rd year book mathematics

*bscinorganicchemistrypracticalpaper pub bitchute* - Mar 31 2022

web fundamentals of inorganic chemistry which degree in britain a practical guide to scientific writing in chemistry who s

who practical inductively coupled plasma spectrometry bscinorganicchemistrypracticalpaper downloaded from pub bitchute com by guest bradley tanya advanced practical organic chemistry 3rd edition s

**bsc inorganic chemistry practical paper pdf 2023 black ortax** - Jul 15 2023

web inorganic chemistry ii for m sc course for universities in uttarakhand dr geeta tiwari this book entitled inorganic chemistry ii is an effort to present the subject matter in a comprehensible and easily understandable form this textbook is purposefully prepared for the postgraduate

**theoretical and inorganic chemistry i previous question paper** - Nov 07 2022

web jul 31 2021 theoretical and inorganic chemistry i previous question papers calicut university ug degree course first semester bsc chemistry theoretical and inorganic chemistry i old year question papers are available to download university calicut university course bsc chemistry semester 1 semester subject

*bsc inorganic chemistry practical paper copy thor byteorbit* - Sep 05 2022

web bsc inorganic chemistry practical paper 1 bsc inorganic chemistry practical paper chemistry bsc university of leicester bsc books notes free download pdf 1st 2nd 3rd year b sc first year 2016 paper i paper i ch 101 inorganic b sc first year chemistry practical for b sc part ii dr deepak pant

*inorganic chemistry bsc chemistry notes teachmint* - Jul 03 2022

web chemistry by dinesh hada dec 22 2021 study material organic chemistry bsc 1st b sc chemistry 0 likes 68 views vinod bishnoi

*bsc 1st year important questions in chemistry free download* - Dec 08 2022

web mar 5 2022 recommended books chemistry for degree students first year as per the ugc curriculum the book comprises three parts inorganic organic and physical chemistry aimed at students of first year in chemistry the book is written in a logical clear and understandable style buy now

*investigation of sensitive sers detection rsc publishing* - Feb 27 2022

web sep 15 2023 surface enhanced raman scattering is a powerful spectroscopy technique due to its ultra sensitive characterization however it is usually detected based on direct contact between the noble metal substrates and the probe molecule which limits the practical applications here we propose a detection method to const journal of

**bsc inorganic chemistry practical paper** - Aug 04 2022

web bsc inorganic chemistry practical paper this is likewise one of the factors by obtaining the soft documents of this bsc inorganic chemistry practical paper by online you might not require more become old to spend to go to the book inauguration as capably as search for them in some cases you likewise complete not discover the pronouncement