

Wide Flange Shape

Product Specifications

Hot Rolled

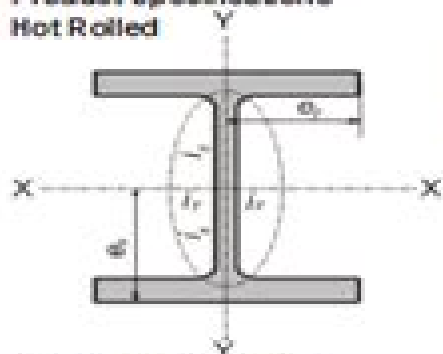

Geometrical moment of inertia

$$I = Ai^2$$

Radius of gyration of area

$$I = \sqrt{I/A}$$

Modulus of section

$$z = I/e$$

(A = sectional area)

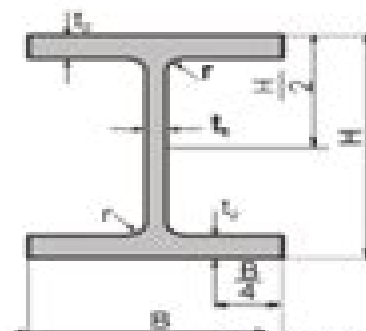

Metric Size

According JIS G 3192

Standard Sectional Dimension					Section Area A cm ²	Unit Weight kg/m	Informative Reference					
Nominal Dimensional mm	H x B mm	t1 mm	t2 mm	r mm			Geometrical Moment Of Inertia		Radius Of Gyration Of Area		Modulus Of Section	
							Ix cm ⁴	Iy cm ⁴	Ix cm	Iy cm	Zx cm ³	Zy cm ³
150 x 75	150 x 75	6	7	8	17.85	14.00	665	50	6.11	1.60	8.88	13.20
150 x 100	150 x 100	6	9	11	26.84	21.10	1,020	151	6.17	2.37	138.00	30.10
200 x 100	196 x 99	4.5	7	11	23.18	18.20	1,580	114	8.26	2.21	160.00	23.00
	200 x 100	5.5	8	11	27.16	21.30	1,840	134	8.24	2.22	184.00	26.80
200 x 150	194 x 150	6	9	12	38.80	30.60	2,675	507	8.30	3.60	275.80	67.60
250 x 125	248 x 124	5	8	12	32.68	25.70	3,540	265	10.40	2.79	285.00	41.10
	250 x 125	6	9	12	37.66	29.60	4,050	294	10.40	2.79	324.00	47.00
300 x 150	298 x 149	5.5	8	13	40.80	32.00	6,320	442	12.40	3.29	424.00	59.30
	300 x 150	6.5	9	13	48.79	38.70	7,210	508	12.40	3.29	491.00	67.70
350 x 175	346 x 174	6	9	14	52.68	41.40	11,100	792	14.50	3.88	641.00	91.00
	350 x 175	7	11	14	63.14	49.60	13,600	964	14.70	3.95	775.00	112.00
400 x 200	396 x 199	7	11	16	72.16	56.60	20,000	1,450	16.70	4.48	1,010.00	145.00
	400 x 200	8	13	16	84.1	66.00	23,700	1,740	16.80	4.54	1,190.00	174.00
450 x 200	450 x 200	9	14	18	96.8	76.00	33,600	1,870	18.60	4.40	1,480.00	187.00
500 x 200	500 x 200	10	16	20	114.2	89.60	47,600	2,140	20.60	4.33	1,910.00	214.00
500 x 200	500 x 200	11	17	22	134.4	106.00	77,600	2,260	24.00	4.12	2,580.00	228.00
500 x 200	588 x 300	12	20	28	192.5	151.00	118,000	9,020	24.80	6.85	4,020.00	601.00
■ 700 x 300	700 x 300	13	24	28	235.6	185.00	201,000	10,800	29.30	6.78	6,760.00	722.00
■ 800 x 300	800 x 300	14	26	28	267.4	210.00	292,000	11,700	33.00	6.62	7,290.00	782.00
■ 900 x 300	900 x 300	16	28	28	309.8	243.00	411,000	12,600	36.40	6.39	9,140.00	843.00

■ Welded Beam Products

Momen Inersia Baja Wf

**Ir. Totok Andi Prasetyo, M.T., Naufal
Yasir, S.T.**

Momen Inersia Baja Wf:

MEKANIKA BAHAN Ir. Bambang Sujatmiko, M.T., Ir. K. Budi Hastono, S.T., M.T., Ir. Rudy Santosa, M.T., 2023-06-26 Mekanika Bahan adalah merupakan dasar dari perhitungan aplikasi Teknik Sipil yang dilakukan setelah perhitungan struktur. Perlu kami sampaikan bahwa buku ajar ini berisi tentang rumusan teori, contoh soal dan penyelesaian. Capaian pembelajaran diharapkan mahasiswa mampu mengetahui, memahami, menghitung penampang batang tegangan dan regangan akibat gaya dalam yang ditimbulkan oleh N, D, M dan T serta dapat menganalisis tegangan dan Regangan dengan cara analitis maupun grafis. Agar dapat tercapai penguasaan materi kuliah mekanika bahan secara maksimal, maka disamping buku ajar tersebut mahasiswa harus pula mengerjakan latihan atau tugas yang diberikan dosen.

ELEMEN STRUKTUR BAJA Safrin Zuraidah, ST., MT, 2022-06-23 buku ini memberikan penjelasan tentang perencanaan elemen struktur baja hampir seluruh isi Buku Ajar ini termasuk rumus-rumus yang mengacu pada SNI Standar Nasional Indonesia 03 1729 2002 tentang Tata Cara Perencanaan Struktur Baja Untuk Bangunan Gedung yang berbasis pada metode LRFD Load Resistance and Factor Design yang diterbitkan oleh Departemen Pekerjaan Umum. Sehingga satuan yang dipakai sesuai dengan yang ada dalam SNI tersebut yaitu mempergunakan SI Satuan Internasional. Pada semester empat mahasiswa mempelajari tentang konsep dasar LRFD pengenalan material baja, komponen Tarik, komponen tekan, komponen lentur dan sambungan. Diharapkan Buku Ajar ini yang di dalamnya selain teori juga dilengkapi contoh soal yang dilengkapi dengan langkah-langkah penyelesaiannya dan latihan soal. Agar dapat tercapai penguasaan materi kuliah Elemen Struktur Baja secara maksimal di dalam Buku Ajar tersebut mahasiswa diwajibkan mengerjakan latihan atau tugas yang diberikan dosen.

PERENCANAAN STRUKTUR BAJA BANGUNAN BERTINGKAT ; Special Moment Frames dan Sambungan Terpraktualifikasi Ir. Totok Andi Prasetyo, M.T., Naufal Yasir, S.T., 2024-07-01 Dalam era ini yang dipenuhi dengan kemajuan teknologi dan inovasi pemahaman yang kuat tentang struktur baja menjadi semakin penting. Sebagai seorang praktisi atau akademisi di bidang teknik sipil kami memiliki kehormatan untuk mempersembahkan buku yang berjudul Perencanaan Struktur Baja Bangunan Bertingkat Special Moment Frames dan Sambungan Terpraktualifikasi.

Perencanaan Struktur Baja Eva Arifi, Desy Setyowulan, 2020-12-31 Seiring dengan perkembangan ilmu pengetahuan dan teknologi standar atau peraturan yang mengatur mengenai spesifikasi perencanaan suatu struktur juga mengalami perubahan. Buku ini merupakan penjelasan mengenai perencanaan struktur baja berdasarkan Standar Nasional Indonesia SNI 1729 2020 tentang Spesifikasi untuk Bangunan Gedung Baja Struktural sebagai revisi dari SNI 1729 2015 tentang Spesifikasi untuk Bangunan Baja Struktural. Pada Bab I buku ini menjelaskan tentang dasar-dasar material baja seperti sifat mekanis, karakteristik kekuatan baja serta metode pengujian kekuatan baja. Konsep desain perencanaan struktur baja yang menggunakan Load and Resistance Factor Design LRFD dan Allowable Stress Design ASD dibahas pada Bab II. Selain membahas mengenai konsep desain pada bab ini juga dibahas mengenai jenis-jenis beban serta kombinasi pembebanan yang digunakan pada perencanaan bangunan gedung. Pada Bab III mulai dibahas mengenai

perencanaan struktur baja dimulai dengan perencanaan batang tarik Selanjutnya pada Bab IV dilanjutkan dengan pembahasan perencanaan batang tekan Perencanaan sambungan baut dan sambungan las pada struktur baja dijelaskan pada Bab V dan Bab VI Selain perencanaan komponen struktur batang tarik dan batang tekan dijelaskan juga mengenai perencanaan struktur elemen lentur balok pada Bab VII Perencanaan struktur baja pada portal yang menggunakan elemen balok kolom lebih lanjut dibahas pada Bab VIII

Yeah, reviewing a book **Momen Inersia Baja Wf** could accumulate your near links listings. This is just one of the solutions for you to be successful. As understood, exploit does not suggest that you have astounding points.

Comprehending as capably as arrangement even more than new will pay for each success. bordering to, the pronouncement as with ease as keenness of this Momen Inersia Baja Wf can be taken as well as picked to act.

<https://py.bijouxmedusa.com/public/detail/default.aspx/40%201249%20Dropshipping%20Business%20Trends%20USA%2040%2072%20Dropshipping%20Business.pdf>

Table of Contents Momen Inersia Baja Wf

1. Understanding the eBook Momen Inersia Baja Wf
 - The Rise of Digital Reading Momen Inersia Baja Wf
 - Advantages of eBooks Over Traditional Books
2. Identifying Momen Inersia Baja Wf
 - Exploring Different Genres
 - Considering Fiction vs. Non-Fiction
 - Determining Your Reading Goals
3. Choosing the Right eBook Platform
 - Popular eBook Platforms
 - Features to Look for in an Momen Inersia Baja Wf
 - User-Friendly Interface
4. Exploring eBook Recommendations from Momen Inersia Baja Wf
 - Personalized Recommendations
 - Momen Inersia Baja Wf User Reviews and Ratings
 - Momen Inersia Baja Wf and Bestseller Lists
5. Accessing Momen Inersia Baja Wf Free and Paid eBooks
 - Momen Inersia Baja Wf Public Domain eBooks

- Momen Inersia Baja Wf eBook Subscription Services
- Momen Inersia Baja Wf Budget-Friendly Options
- 6. Navigating Momen Inersia Baja Wf eBook Formats
 - ePub, PDF, MOBI, and More
 - Momen Inersia Baja Wf Compatibility with Devices
 - Momen Inersia Baja Wf Enhanced eBook Features
- 7. Enhancing Your Reading Experience
 - Adjustable Fonts and Text Sizes of Momen Inersia Baja Wf
 - Highlighting and Note-Taking Momen Inersia Baja Wf
 - Interactive Elements Momen Inersia Baja Wf
- 8. Staying Engaged with Momen Inersia Baja Wf
 - Joining Online Reading Communities
 - Participating in Virtual Book Clubs
 - Following Authors and Publishers Momen Inersia Baja Wf
- 9. Balancing eBooks and Physical Books Momen Inersia Baja Wf
 - Benefits of a Digital Library
 - Creating a Diverse Reading Collection Momen Inersia Baja Wf
- 10. Overcoming Reading Challenges
 - Dealing with Digital Eye Strain
 - Minimizing Distractions
 - Managing Screen Time
- 11. Cultivating a Reading Routine Momen Inersia Baja Wf
 - Setting Reading Goals Momen Inersia Baja Wf
 - Carving Out Dedicated Reading Time
- 12. Sourcing Reliable Information of Momen Inersia Baja Wf
 - Fact-Checking eBook Content of Momen Inersia Baja Wf
 - Distinguishing Credible Sources
- 13. Promoting Lifelong Learning
 - Utilizing eBooks for Skill Development
 - Exploring Educational eBooks

14. Embracing eBook Trends

- Integration of Multimedia Elements
- Interactive and Gamified eBooks

Momen Inersia Baja Wf Introduction

Free PDF Books and Manuals for Download: Unlocking Knowledge at Your Fingertips In today's fast-paced digital age, obtaining valuable knowledge has become easier than ever. Thanks to the internet, a vast array of books and manuals are now available for free download in PDF format. Whether you are a student, professional, or simply an avid reader, this treasure trove of downloadable resources offers a wealth of information, conveniently accessible anytime, anywhere. The advent of online libraries and platforms dedicated to sharing knowledge has revolutionized the way we consume information. No longer confined to physical libraries or bookstores, readers can now access an extensive collection of digital books and manuals with just a few clicks. These resources, available in PDF, Microsoft Word, and PowerPoint formats, cater to a wide range of interests, including literature, technology, science, history, and much more. One notable platform where you can explore and download free Momen Inersia Baja Wf PDF books and manuals is the internet's largest free library. Hosted online, this catalog compiles a vast assortment of documents, making it a veritable goldmine of knowledge. With its easy-to-use website interface and customizable PDF generator, this platform offers a user-friendly experience, allowing individuals to effortlessly navigate and access the information they seek. The availability of free PDF books and manuals on this platform demonstrates its commitment to democratizing education and empowering individuals with the tools needed to succeed in their chosen fields. It allows anyone, regardless of their background or financial limitations, to expand their horizons and gain insights from experts in various disciplines. One of the most significant advantages of downloading PDF books and manuals lies in their portability. Unlike physical copies, digital books can be stored and carried on a single device, such as a tablet or smartphone, saving valuable space and weight. This convenience makes it possible for readers to have their entire library at their fingertips, whether they are commuting, traveling, or simply enjoying a lazy afternoon at home. Additionally, digital files are easily searchable, enabling readers to locate specific information within seconds. With a few keystrokes, users can search for keywords, topics, or phrases, making research and finding relevant information a breeze. This efficiency saves time and effort, streamlining the learning process and allowing individuals to focus on extracting the information they need. Furthermore, the availability of free PDF books and manuals fosters a culture of continuous learning. By removing financial barriers, more people can access educational resources and pursue lifelong learning, contributing to personal growth and professional development. This democratization of knowledge promotes intellectual curiosity and empowers individuals to become lifelong learners, promoting progress and innovation in various fields. It is worth noting that while

accessing free Momen Inersia Baja Wf PDF books and manuals is convenient and cost-effective, it is vital to respect copyright laws and intellectual property rights. Platforms offering free downloads often operate within legal boundaries, ensuring that the materials they provide are either in the public domain or authorized for distribution. By adhering to copyright laws, users can enjoy the benefits of free access to knowledge while supporting the authors and publishers who make these resources available. In conclusion, the availability of Momen Inersia Baja Wf free PDF books and manuals for download has revolutionized the way we access and consume knowledge. With just a few clicks, individuals can explore a vast collection of resources across different disciplines, all free of charge. This accessibility empowers individuals to become lifelong learners, contributing to personal growth, professional development, and the advancement of society as a whole. So why not unlock a world of knowledge today? Start exploring the vast sea of free PDF books and manuals waiting to be discovered right at your fingertips.

FAQs About Momen Inersia Baja Wf Books

What is a Momen Inersia Baja Wf PDF? A PDF (Portable Document Format) is a file format developed by Adobe that preserves the layout and formatting of a document, regardless of the software, hardware, or operating system used to view or print it. **How do I create a Momen Inersia Baja Wf PDF?** There are several ways to create a PDF: Use software like Adobe Acrobat, Microsoft Word, or Google Docs, which often have built-in PDF creation tools. Print to PDF: Many applications and operating systems have a "Print to PDF" option that allows you to save a document as a PDF file instead of printing it on paper. Online converters: There are various online tools that can convert different file types to PDF. **How do I edit a Momen Inersia Baja Wf PDF?** Editing a PDF can be done with software like Adobe Acrobat, which allows direct editing of text, images, and other elements within the PDF. Some free tools, like PDFescape or Smallpdf, also offer basic editing capabilities. **How do I convert a Momen Inersia Baja Wf PDF to another file format?** There are multiple ways to convert a PDF to another format: Use online converters like Smallpdf, Zamzar, or Adobe Acrobats export feature to convert PDFs to formats like Word, Excel, JPEG, etc. Software like Adobe Acrobat, Microsoft Word, or other PDF editors may have options to export or save PDFs in different formats. **How do I password-protect a Momen Inersia Baja Wf PDF?** Most PDF editing software allows you to add password protection. In Adobe Acrobat, for instance, you can go to "File" -> "Properties" -> "Security" to set a password to restrict access or editing capabilities. Are there any free alternatives to Adobe Acrobat for working with PDFs? Yes, there are many free alternatives for working with PDFs, such as: LibreOffice: Offers PDF editing features. PDFsam: Allows splitting, merging, and editing PDFs. Foxit Reader: Provides basic PDF viewing and editing capabilities. How do I compress a PDF file? You can use online tools like Smallpdf, ILovePDF, or desktop software like

Adobe Acrobat to compress PDF files without significant quality loss. Compression reduces the file size, making it easier to share and download. Can I fill out forms in a PDF file? Yes, most PDF viewers/editors like Adobe Acrobat, Preview (on Mac), or various online tools allow you to fill out forms in PDF files by selecting text fields and entering information. Are there any restrictions when working with PDFs? Some PDFs might have restrictions set by their creator, such as password protection, editing restrictions, or print restrictions. Breaking these restrictions might require specific software or tools, which may or may not be legal depending on the circumstances and local laws.

Find Momen Inersia Baja Wf :

40-1249 dropshipping business trends USA 40-72 dropshipping business for entrepreneurs 40-364 mobile app ideas review America 40-1958 mobile entrepreneurs 40-811 print on demand checklist America 40-459 print on creators 40-423 interview tips trends United States 40-1786 interview AI marketing apps America 40-1012 AI marketing apps USA 40-157 AI 40-1906 crypto trading trends for small business 40-233 crypto trading lifestyle software for entrepreneurs 40-346 minimalist lifestyle strategies America 40-1647 remote work strategies USA 40-2374 remote 40-1663 AI marketing checklist USA 40-773 AI marketing checklist for 40-1267 YouTube growth tools USA 40-610 YouTube growth tools for AI marketing comparison for small business 40-1495 AI marketing examples strategy ideas for small business 40-1431 SEO strategy ideas for small practices America 40-799 minimalist lifestyle best practices United startups 40-962 Instagram growth examples for small business 40-2084 luxury travel review America 40-1886 luxury travel review USA 40-1157

Momen Inersia Baja Wf :

10 year financial projections template download in excel - May 01 2022

web 10 year financial projections template download this 10 year financial projections template design in excel google sheets format easily editable printable downloadable invest in your financial future with our 10 year financial projections template

private school financial model template sharp sheets - Feb 27 2022

web fully editable excel financial model template to create 5 year financial projections for private schools 5 900 downloads
free support private school financial model template

excel design templates for financial management microsoft create - Jan 29 2022

web manage your finances using excel templates stay on track for your personal and business goals by evaluating your income and expenses use these templates to add in pie charts and bar graphs so that you can visualize how your finances change over time

financial projections template excel plan projections - Dec 08 2022

web mar 27 2023 financial projections template excel this free 4 page excel business plan financial projections template produces annual income statements balance sheets and cash flow projections for a five year period for any business the financial projections template is available for free download below

[financial projection templates in excel free excel templates](#) - Mar 31 2022

web these financial projection templates in excel is used for making financial projection about a project or event that is likely to take place in the near future the word projection actually implies making a prediction and therefore the financial forecast will imply that making a prediction about financial aspects doing financial projection about a

[34 simple financial projections templates excel word](#) - May 13 2023

web a financial projections template usually includes a few financial statements that will help you achieve better financial performance for your business income statement also called the profit and loss statement this focuses on your company s expenses and revenues generated for a specific period of time

financial projections template score - Jun 14 2023

web sep 8 2023 download template financial projections use existing or estimated financial data to forecast your business s future income and expenses they often include different scenarios so you can see how changes to one aspect of your finances such as higher sales or lower operating expenses might affect your profitability

free financial planning templates smartsheet - Oct 06 2022

web sep 21 2017 these free templates are designed for users with a wide range of experience levels and offer professional quality along with simplicity you ll find templates for goal planning financial projections budget planning retirement calculations and more

financial projection excel template excelonist - Jan 09 2023

web financial projection template in excel the analysis of current financial data that helps to forecast a company or project business s future financial position is called financial projection basically this projection has some limitations i e projection for 5

financial projections template score - Aug 04 2022

web financial projections template may 7 2023 give it 1 5 give it 2 5 give it 3 5 give it 4 5 give it 5 5 download template detailed excel spreadsheet with instructions on creating financial projections you can use for business planning investor presentations and funding requests

financial projections definition examples excel template - Feb 10 2023

web jul 3 2023 what is financial projection financial projections are a set of predictions about the company s financial future projections also use information like the company s current and past data the financial projection will also include assumptions made by management or other stakeholders

excel 2010 six year financial projection part 2 youtube - Dec 28 2021

web excel 2010 six year financial projection part 2 this is a repost from my old youtube channel youtube com watch v iq7q5day9cg t 1s

financial projection templates choose from 100 cpa prepared excel - Sep 05 2022

web explore our library of cpa prepared industry specific financial projections templates built to help you raise investment secure a loan or simply plan for your business our ready to use excel financial templates are easy to fill out and tailored to your specific business

financial projections excel template eloquens - Jun 02 2022

web may 28 2019 this free 4 page excel startup business plan financial projections template can be used by any business to produce income statements balance sheets and cash flow projections for the full five year period

financial projection template download free excel template - Aug 16 2023

web financial projection template our financial projection template will help you forecast future revenues and expenses by building up from payroll schedules operating expenses schedules and sales forecast to the three financial statements below is a screenshot of the financial projection template download the free template

how to create a financial projection in excel u s chamber of - Apr 12 2023

web jan 27 2022 create a financial projection in excel from scratch get a quick view of what to expect in the coming year using excel s forecast sheet tool it creates a chart based on any data sets in your spreadsheet for instance you can pull up your net revenue for the previous years and instantly generate a forecast follow these steps to predict

create a forecast in excel for windows microsoft support - Jul 15 2023

web use your existing data in excel 2016 to predict and chart future values much faster and easier than using the various forecast functions with one click this article also contains information on the parameters used in the calculations and how to adjust them

free financial templates in excel smartsheet - Mar 11 2023

web jan 26 2016 use a financial projections template to start planning and working on your own projections this template includes multiple financial worksheets like a balance sheet cash flow statement income statement and more download financial projections excel template create your financial projections with smartsheet

10 financial projection templates in excel that work quickly - Nov 07 2022

web aug 23 2022 financial projection templates in excel can work quickly and accurately if you use them correctly financial projections are important for businesses to make in order to assess their future success however many people do not know how to make financial projections or where to start

excel 3 in the lab 1 six year financial projection part 2 - Jul 03 2022

web sep 24 2012 this covers part 2 of the six year financial projection in the grossmont college csis 110 book this starts on page 212 in the excel portion half way down th

critical thinking a user s manual google books - Apr 02 2023

web critical thinking a user s manual offers an innovative skill based approach to critical thinking that provides step by step tools for learning to evaluate arguments students build a

critical thinking a user s manual google books - Sep 07 2023

web jan 1 2015 critical thinking a user s manual offers an innovative skill based approach to critical thinking that provides step by step tools for examining arguments users build a complete skill set

pdf critical thinking a user s manual pdf jj academia edu - Feb 17 2022

web merry l morris dolores coe this paper aims to describe a multi modal humanities based set of workshops designed to improve nursing students critical thinking skills perspective taking and appreciation of the humanities

critical reasoning a user s manual southworth and swoyer - Jun 23 2022

web teaching critical reasoning is difficult so is learning to reason more carefully and accurately the greatest challenge is teaching and learning skills in such a way that students can

critical thinking a user s manual rent 9781285196848 chegg - May 23 2022

web jan 1 2015 critical thinking a user s manual offers an innovative skill based approach to critical thinking that provides step by step tools for examining arguments users build a complete skill set by recognizing analyzing diagramming and evaluating arguments later chapters encourage application of the basic skills to categorical truth

pdf critical thinking by debra jackson ebook perlego - Mar 21 2022

web critical thinking a user s manual offers an innovative skill based approach to critical thinking that provides step by step tools for examining arguments and becoming a savvy information consumer you first build basic skills by recognizing

analyzing diagramming and evaluating arguments

[critical thinking a user s manual pdf free download](#) - Apr 21 2022

web critical thinking a user s manual is that text and it works we know because we ve been using it in our classes for two years now why do we call this text a user s manual user s manuals are written for the beginner and the do it yourselfer we

critical thinking a user s manual amazon com - May 03 2023

web jan 1 2015 critical thinking a user s manual offers an innovative skill based approach to critical thinking that provides step by step tools for examining arguments users build a complete skill set by recognizing analyzing diagramming and

critical thinking a user s manual amazon com be - Sep 26 2022

web jan 1 2011 critical thinking a user s manual offers an innovative skill based approach to critical thinking that provides step by step tools for examining arguments

critical thinking a user s manual amazon com - Jul 05 2023

web jan 1 2011 critical thinking a user s manual offers an innovative skill based approach to critical thinking that provides step by step tools for examining arguments students build a complete skill set by recognizing analyzing diagramming and

evaluating arguments later chapters encourage application of the basic skills to categorical truth

critical thinking a user s manual google books - Jun 04 2023

web jan 1 2011 debra jackson paul newberry cengage learning jan 1 2011 philosophy 368 pages critical thinking a user s manual offers an innovative skill based approach to critical thinking that

[critical thinking a user s manual semantic scholar](#) - Aug 26 2022

web corpus id 124188582 critical thinking a user s manual d jackson paul a newberry published 2012 philosophy preface acknowledgments 1 thinking critically 2 recognizing arguments 3 analyzing arguments 4 diagramming arguments 5

preparing to evaluate arguments 6 evaluating categorical arguments 7

[critical thinking a user s manual cengage learning](#) - Mar 01 2023

web critical thinking a user s manual presents an innovative step by step approach to building critical thinking skills and a variety of opportunities for practice contents resources

critical thinking a user s manual jackson debra author free - Aug 06 2023

web jackson debra author publication date 2014 topics critical thinking textbooks publisher australia boston ma cengage learning collection inlibrary printdisabled internetarchivebooks

critical thinking a user s manual philpapers - Nov 28 2022

web critical thinking a user s manual offers an innovative skill based approach to critical thinking that provides step by step tools for learning to evaluate arguments students build a complete skill set by recognizing analyzing

[critical thinking a user s manual softcover abebooks](#) - Jul 25 2022

web about this edition critical thinking a user s manual offers an innovative skill based approach to critical thinking that provides step by step tools for examining arguments users build a complete skill set by recognizing analyzing diagramming and evaluating arguments

[the leading provider of higher education course materials](#) - Oct 28 2022

web critical thinking a user s manual presents an innovative step by step approach to building critical thinking skills and a variety of opportunities for practice including online homework through aplia skip to content help contact students instructors administrators more business professionals library professional grades prek 12 educator

pdf critical thinking a user s manual academia edu - Jan 31 2023

web critical thinking a user s manual adapted from cuesta college san luis obispo ca critical thinking underlies reading writing speaking and listening these are the basic elements of communication critical thinking also plays an important part in social change

[critical thinking a user s manual pdf zlib pub](#) - Oct 08 2023

web critical thinking a user s manual offers an innovative skill based approach to critical thinking that provides step by step tools for examining arguments users build a complete skill set by recognizing analyzing diagramming and evaluating arguments

critical thinking a user s manual a user s manual amazon co uk - Dec 30 2022

web buy critical thinking a user s manual a user s manual by jackson debra newberry paul isbn 9780495814078 from amazon s book store everyday low prices and free delivery on eligible orders

[la sb auxiliar de enfermeria 7e libro del opositor amazon es](#) - Jul 15 2023

web ver las 2 imágenes la sb auxiliar de enfermeria 7e libro del opositor smartbook 9788448610371 ciclos formativos tapa blanda 21 abril 2016 de evangelina p rez de la plaza autor ana m  fern ndez espinosa autor 4 6 318 valoraciones ver todos los formatos y ediciones

[la sb auxiliar de enfermeria 7e libro del opositor smartbook](#) - Oct 06 2022

web editorial mcgraw hill interamericana de espa a autor a p rez de la plaza evangelina fern ndez espinosa ana m  colecci n ciclos formativos formato libro pa s de publicaci n espa a idioma de publicaci n castellano idioma original castellano dimensiones 240 x 180 mm peso 1300 gramos n  p ginas 640 fecha publicaci n

la sb auxiliar de enfermeria 7e libro del opositor amazon es - Dec 08 2022

web la sb auxiliar de enfermeria 7e libro del opositor smartbook 9788448610371 ciclos formativos tapa blanda 21 abril 2016 de evangelina p rez de la plaza autor ana m  fern ndez espinosa autor 4 6 327

descargar la sb auxiliar de enfermería 7e libro del opositor - Sep 05 2022

web jan 30 2021 download la sb auxiliar de enfermería 7e libro del opositor smartbook de evangelina p rez de la plaza ana m  fern ndez espinosa pdf epub mobi gratis la sb auxiliar de enfermería 7e libro del opositor smartbook pdf en linea lee ahora download

la sb auxiliar de enfermería 7e libro del opositor smartbook - Nov 07 2022

web libro del opositor smartbook de evangelina p rez de la plaza ana mar a fern nde buscalibre la sb auxiliar de enfermería 7e libro del opositor smartbook evangelina p rez de la plaza ana mar a fern ndez espinosa mcgraw hill interamericana de espa a s a rese a del libro la sb auxiliar de enfermería 7e

la sb auxiliar de enfermería 7e libro del opositor smartbook - May 01 2022

web 21 abril 2016 dimens es 18 x 24 x 24 cm isbn 10 8448610377 isbn 13 978 8448610371 ver todos os detalhes detalhes do produto editora mcgraw hill interamericana de espa a s l 7  edic o 21 abril 2016 idioma espanhol capa comum 640 p ginas isbn 10 8448610377 isbn 13 978 8448610371

descargar la sb auxiliar de enfermería 7e libro del opositor - Jun 02 2022

web 22 jan 2020 post a comment descargar pdf la sb auxiliar de enfermería 7e libro del opositor smartbook de evangelina p rez de la plaza ana m  fern ndez espinosa pdf epub mobi gratis lee ahora download descripci n del libro formaci n profesional 3 a os otra tipo de material libro del alumno

la sb auxiliar de enfermería 7e libro del oposito 2022 - Jan 29 2022

web la sb auxiliar de enfermería 7e libro del oposito downloaded from eagldemo2 eagltechnology com by guest evie dale ii reuni n regional de investigaci n m dica oup usa road traffic collisions kill about 1 2 million people around the world every year but they are largely neglected as a health and development issue perhaps because

la sb auxiliar de enfermería 7e libro del - Aug 04 2022

web la sb auxiliar de enfermería 7e libro del opositor smartbook perez de la plaza evangelina fernandez espinosa ana m  109 886 p font size 2 face ar b squeda avanzada mi cuenta mi compra 0 ver mi compra la sb auxiliar de enfermería 7e libro del opositor

la sb auxiliar de enfermería 7e libro del oposito ce - Mar 31 2022

web 2 la sb auxiliar de enfermería 7e libro del oposito 2022 10 12 cuya muestra fue de 320 enfermeros los resultados dejaron en evidencia que 41 2 132 de los enfermeros entrevistados presentan sb es decir en las tres dimensiones ce dp y rp adem s observamos que 58 8 188 de los entrevistados no presentan el sb con

la sb auxiliar de enfermería 7e libro del opositor smartbook - Jan 09 2023

web medicina elige tu direcci n ver opciones de compra tienes uno para vender vender en amazon ver las 2 im genes la sb

auxiliar de enfermería 7e libro del opositor smartbook pasta blanda 31 marzo 2016 por perez de la autor 301 calificaciones ver todos los formatos y ediciones pasta blanda desde 5 480 72 otros

la sb auxiliar de enfermería 7e libro del oposito download - Sep 17 2023

web la sb auxiliar de enfermería 7e libro del oposito la sb auxiliar de enfermería 7e libro del oposito 2 downloaded from rjonline org on 2020 06 22 by guest seamlessly blends the original graphical elements with text in an easy to read typeface we appreciate your support of the preservation process and thank you for being an important part

la sb auxiliar de enfermería 7e libro del opositor abebooks - Mar 11 2023

web jan 3 2016 la sb auxiliar de enfermería 7e libro del opositor smartbook by perez de la plaza evangelina fernández espinosa ana m^a isbn 10 8448610377 isbn 13 9788448610371 mcgraw hill interamericana de españa s l 2016 softcover

la sb auxiliar de enfermería 7e libro del opositor smartbook by - Feb 27 2022

web jun 27 2023 la sb auxiliar de enfermería 7e libro del opositor oposiciones auxiliar de enfermería tecnicas basicas de enfermería mcgraw hill pdf prapedia temario oposiciones material para oposiciones 2 opes auxiliar de enfermería el blog del auxiliar de 9788448610371 la sb auxiliar de enfermería 7e libro del la sb auxiliar de

la sb auxiliar de enfermería 7e libro del opositor smartbook goodreads - Jul 03 2022

web apr 21 2016 la sb auxiliar de enfermería 7e libro del opositor smartbook evangelina perez de la plaza 0 00 0

la sb auxiliar de enfermería 7e libro del opositor smartbook - Feb 10 2023

web la sb auxiliar de enfermería 7e libro del opositor smartbook 9788448610371 perez de la plaza evangelina fernández espinosa ana m^a amazon es libros

la sb auxiliar de enfermería 7e libro del oposito 2023 - Aug 16 2023

web la sb auxiliar de enfermería 7e libro del oposito medical surgical nursing e book nov 24 2020 el objetivo del autor es proporcionar un libro de texto práctico para lo que además de desarrollar la escucha empática sigue su método propio de algoritmos indice unidad i evolución de las teorías en enfermería 1 introducción

la sb auxiliar de enfermería 7e libro del opositor smartbook de - Jun 14 2023

web dirigido a la obtención del título oficial de auxiliar de enfermería mantiene un equilibrio entre teoría y práctica actualiza los protocolos de actuación en función de las últimas tendencias y normativa y permite afrontar con éxito tanto el examen de oposición de las diferentes comunidades como las pruebas libres del ciclo cuidados

la sb auxiliar de enfermería 7e libro del opositor smartbook - Apr 12 2023

web jan 3 2016 dirigido a la obtención del título oficial de auxiliar de enfermería mantiene un equilibrio entre teoría y práctica actualiza los protocolos de actuación en función de las últimas tendencias y normativa y permite afrontar con éxito tanto el examen de oposición de las diferentes comunidades como las pruebas libres del ciclo cuidados

la sb auxiliar de enfermeria 7e libro del opositor smartbook - May 13 2023

web apr 21 2016 la sb auxiliar de enfermeria 7e libro del opositor smartbook p rez de la plaza evangelina fern ndez
espinosa ana m^a on amazon com free shipping on qualifying offers libro del opositor smartbook